



Techno India NJR Institute of Technology
Academic Administration of Techno NJR Institute
LAB Syllabus Deployment

Name of Faculty	: Mr. Jitendra Choubisa	Subject Code: 3CE4-23
Subject	: Computer Aided Civil Engineering Drawing	
Department	: Civil Engineering	Sem: III
Total No. of Lectures Planned: 13		

COURSE OUTCOMES HERE (3 OUTCOMES)

At the end of this course students will be able to:

CO1. Able to understand the basic command, principles and features behind AutoCAD.

CO2. Able to draft the plan, elevation and sectional views of buildings

Lecture No.	Unit	Topic
1	1	Drawing of walls a. Brick and Stone masonry
2	1	Cross section of external wall from foundation to parapet
3	1	Partition wall, cavity wall and
4	2	Pointing, Arches, Lintels and Floors
5	3	Doors and Windows
6	3	Doors and Windows
7	4	Stairs, Cross section of Dog legged stairs
8	4	Stairs, Cross section of Dog legged stairs
9	5	Roofs: Flat and Pitched roof (Steel truss)
10	6	Development of Front Elevation and Sectional Elevation from a given plan
11	6	Development of Front Elevation and Sectional Elevation from a given plan
12	7	Development of Plan, Front Elevation and Sectional Elevation from line diagram
13	7	Development of Plan, Front Elevation and Sectional Elevation from line diagram

For Techno India NJR Institute of Technology

पंकज पौरवाल
Dr. Pankaj Kumar Porwal
(Principal)

पंकज पौरवाल

1. Syllabus

OBJECTIVES:

To introduce the students to draft the plan, elevation and sectional views of buildings in accordance with development and control rules satisfying orientation and functional requirements as per National Building Code.

LIST OF EXPERIMENTS

1. Principles of planning, orientation and complete joinery details (Paneled and Glazed Doors and Windows)
2. Buildings with load bearing walls
3. Buildings with sloping roof
4. R.C.C. framed structures.
5. `Industrial buildings – North light roof structures

OUTCOMES:

The students will be able to draft the plan, elevation and sectional views of the buildings, industrial structures, and framed buildings using computer softwares.

TEXTBOOKS:

1. Sikka V.B., A Course in Civil Engineering Drawing, 4th Edition, S.K.Kataria and Sons, 2015.
2. George Omura, Mastering in Autocad 2005 and Autocad LT 2005– BPB Publications, 2008

REFERENCES:

1. Chuck Eastman, Paul Teicholz, Rafael Sacks, Kathleen Liston, BIM Handbook: A Guide to building information modeling for Owners, Managers, Designers, Engineers, and Contractors, John Wiley and Sons. Inc.,2011.
2. Marimuthu V.M., Murugesan R. and Padmini S., Civil Engineering Drawing-I, Pratheeba Publishers, 2008.
3. Shah.M.G., Kale. C.M. and Patki.S.Y., Building Drawing with an Integrated Approach to Built Environment, Tata McGraw Hill Publishers Limited, 2007.
4. Verma.B.P., Civil Engineering Drawing and House Planning, Khanna Publishers, 2010.

For Techno India NJR Institute of Technology
पंकज पोखवाल
Dr. Pankaj Kumar Porwal
(Principal)

CE8211-COMPUTER AIDED BUILDING DRAWING

Sl. No.	Name of the Experiment	Page No.
CYCLE 1 – EXPERIMENTS		
1	Study Excise -Auto Cad commands	
2	Principles of planning , orientation and complete joinery details (paneled and glazed doors and windows)	
3	A reading room with RCC flat roof	
4	A residential building with single bed room	
5	Library building with RCC slab	
CYCLE 2 – EXPERIMENTS		
6	Fully tiled gabled house	
7	Residential building with load bearing walls and pitched roof	
8	RCC framed building with RCC roof	
9	Primary health centre	
10	School building	
11	School building	

For Techno India NJR Institute of Technology
पंकज पौरवाल
Dr. Pankaj Kumar Porwal
(Principal)

Pre Caution

1. Students should wear lab coat in CAD lab.
2. Students are advised to enter the CAD lab WITH FORMAL SHOES ONLY.
3. They are not supposed to move the systems and monitors.
4. They should enter in the login name and password assigned to each student.
5. Students are advised to complete their record work before the next class.
6. Students are asked to logout from their area and switch off the computers after leaving
7. Students can access the printers through lab technician.
8. Students have free access to use the computers and software available in the lab.
9. During the laboratory hours, accessing the internet is strictly prohibited.
10. Computer games are strictly prohibited in the CAD lab.

'General Instructions to Students'

1. Students should wear lab coat in CAD lab.
2. Students are advised to enter the CAD lab WITH FORMAL SHOES ONLY.
3. They are not supposed to move the systems and monitors.
4. They should enter in the login name and password assigned to each student.
5. Students are advised to complete their record work before the next class.
6. Students are asked to logout from their area and switch off the computers before leaving the lab.
7. Students can access the printers through lab technician.
8. Students have free access to use the computers and software available in the lab.
9. During the laboratory hours, accessing the internet is strictly prohibited.
10. Computer games are strictly prohibited in the CAD lab.

India: NJR Institute of Technology
For Techno
पंकज कुमार पेरवा
Dr. Pankaj Kumar Perwa
(Principal)

CONVENTIONS & SYMBOLS

Sl. No.	Term	Abbreviation
1.	Aggregate	Agg
2.	Approximate	Approx
3.	Asbestos cement	asb/cem
4.	At	@
5.	Air Conditioner	A/C
6.	Brick work	BWK
7.	Brick on edge	BOE
8.	Building	Bldg
9.	Bench mark	BM
10.	Cast-iron	CI
11.	Cement concrete	CC
12.	Centre to centre	c to c, c/c
13.	Cement mortar	CM
14.	Coarse rubble masonry	CR
15.	Random rubble masonry	RR

Sl. No.	Term	Abbreviation
16.	Column	COL
17.	Concrete	CONC
18.	Corrugated	CORR
19.	Cross-section	CS
20.	Cupboard	CB
21.	Collapsible gate	CG
22.	Door	D
23.	Damp proof course	DPC
24.	Diameter	dia,
25.	European water closet	EWC
26.	Figure	Fig.
27.	Finished floor level	FFL
28.	Floor trap	FT
29.	Flushing cistern	FC
30.	Fresh air inlet	FAI
31.	Full supply level	FSL

Sl. No.	Term	Abbreviation
32.	Full tank level	FTL
33.	First floor	FF
34.	Floor level	FL
35.	Flush out latrine	FOL
36.	Galvanized	Galv
37.	Galvanized iron	GI
38.	Grease trap	GRT
39.	Ground level	GL
40.	Grills	G
41.	Gully trap	GT
42.	Height	Ht
43.	Indian water closet	IWC
44.	Imperial (standard) wire gauge	SWG
45.	Inspection chamber	ICH, IC
46.	Intercepting trap	IT

For more India NJR Institute of Technology
 पंकज पोखरेल
 Dr. Pankaj Kumar Porwal
 (Principal)













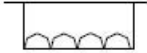





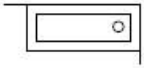
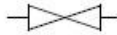
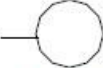

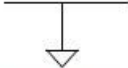
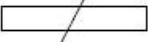

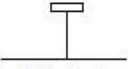

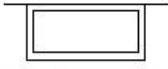







Sl. No.	Term	Abbreviation
47.	Joist	J
48.	Jolly work	JW
49.	Kilo	K
50.	Kilogram	KG
51.	Kilometer	KM
52.	Litre	LT.
53.	Level crossing	LC
54.	Low water level	LWL
55.	Lime mortar	LM
56.	Lime concrete	LC
57.	Maximum flood level	MFL
58.	Maximum water level	MWL
59.	Manhole	MH
60.	Maximum	Max
61.	Mild steel	MS
62.	Millimeter	Mm

Sl. No.	Term	Abbreviation
63.	Minimum	MIN
64.	Not to scale	NTS
65.	Number	No.
66.	Overhead tank	OHT
67.	Plain cement concrete	PCC
68.	Plinth level	PL
69.	Prestressed concrete	PCONC
70.	Radius	Rad
71.	Rainwater pipe	RWP
72.	Rolled section / Rolling shutter	RS
73.	Rolled steel joist or I-section	RSJ OR I
74.	Reinforced Cement Concrete	RCC
75.	Ribbed tor steel	RTS
76.	Stone ware pipe	SWP
77.	Surki mortar	SM
78.	Sink	

Sl.No.	Term	Abbreviation
79.	Soil pipe	SP
80.	Standard	Std
81.	Septic tank	ST
82.	Switch	Sw
83.	Ventilator	V
84.	Vent pipe	VP
85.	Wash basin	WB
86.	Water closet	WC
87.	Window	W
88.	Window cum ventilator	W/V
89.	Water level	WL

For Techno India NJR Institute of Technology
 पंकज पौरवाल
 Dr. Pankaj Kumar Porwal
 (Principal)

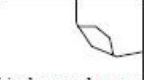
SYMBOLS

 1. Light plug	 11. Immersion heater	 21. Exhaust fan	 31. Urinal stall
 2. Power plug	 12. Bell point	 22. Fan regulator	 32. Indian type WC
 3. Meter	 13. Bell	 23. Rectangular bath	 33. Stop valve or sluice valve
 4. Light bracket	 14. Buzzer	 24. Bidet	 34. Fire extinguisher
 5. Fluorescent light (single)	 15. Telephone instrument point internal	 25. Shower head	 35. Fire hydrant
 6. Fluorescent light (double)	 16. Fire alarm push	 26. Wall lavatory basin	 36. Pump
 7. One-way switch	 17. Aerial	 27. Corner lavatory basin	 37. Gully
 8. Two-way switch	 18. Ceiling fan	 28. Plain kitchen sink	 38. Manhole or inspection chamber
 9. Intermediate switch	 19. Bracket fan	 29. WC	 39. Rainwater outlet
 10. Electric unit heater	 20. Tower rail	 30. Urinal corner hung	 40. Refrigerator

For Techno India NJR Institute of Technology
 पंकज पोखवाल
 Dr. Pankaj Kumar Porwal
 (Principal)

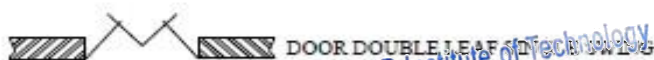
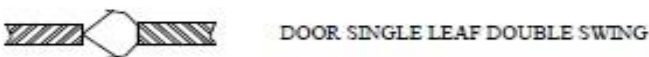
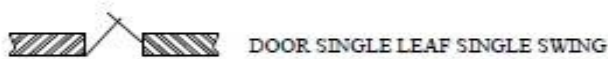
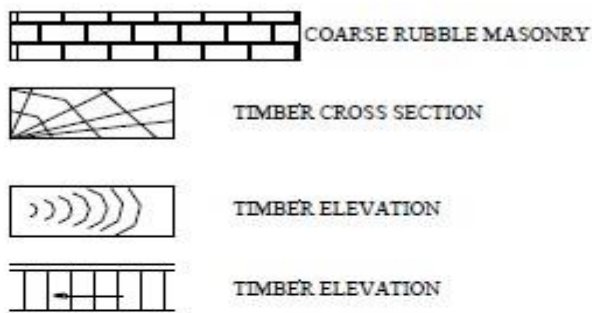
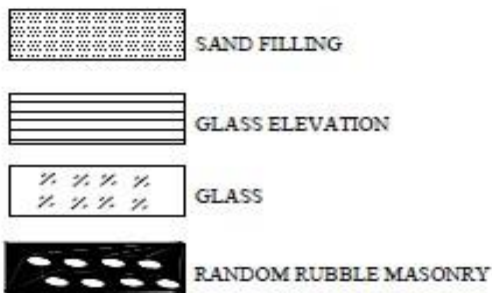
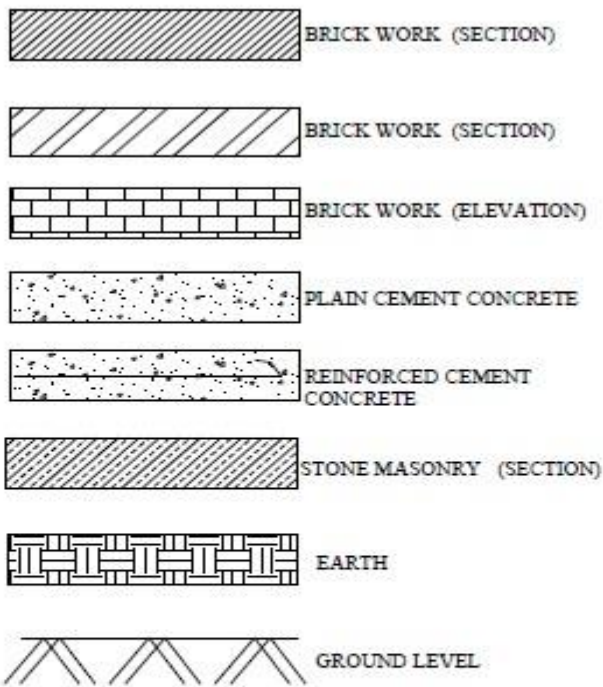

For Techno India NJR Institute of Technology
 Dr. Pankaj Kumar Porwal
 (Principal)

Exp No.:

Date:

1. STUDY EXERCISE – AUTOCAD COMMANDS

AIM

To study the basic commands used in AUTOCAD drawing

OBJECTIVE

To study the basic commands used in AUTOCAD drawing in accordance with development and control rules satisfying orientation and functional requirements as per National Building Code.

KEYWORDS:

Auto Cad Software

THEORY

CAD means Computer Aided Design or Drafting. Auto cad is most widely used software developed by auto desk. Auto cad is a drafting package in almost all engineering branches. There are drafting packages like cad are DIAP, CAMD, and Delights. Auto cad is one of the most popular cad packages. It is a general purpose computer aided design. We can draw geometrical entries like plan, section and elevation of a building.

- We can make accurate drawings like plan, section and elevation of a building.
- Improved engineering productively
- Reduced engineering personal requirement.
- Drawing modification or eraser to intake.
- Drawings prepared in the software can be stored safely.

EXPERIMENT PROCEDURE

STEPS :

ARC	Creates an arc
AREA	Calculates the area and perimeter of objects or of defined areas
ARRAY	Creates multiple copies of objects in a pattern
BHATCH	Fills an enclosed area or selected objects with a hatch pattern
BLOCK	Creates a block definition from objects you select
BOUNDARY	creates a region or a polyline from an enclosed area
BOX	Creates a three dimensional solid box
BREAK	Erases parts of objects or splits an object in two
CAL	Evaluates mathematical and geometric expressions
CHAMFER	Bevels the edges of objects
CIRCLE	Creates a circle

COPY	Duplicates objects
DIST	Measures the distance and angle between two points
DIVIDE	Places evenly spaced point objects or blocks along the length or perimeter of an object
DONUT	Draws filled circles and rings
ELLIPSE	Creates an ellipse or an elliptical arc
ERASE	Removes objects from a drawing
EXPLODE	Breaks a compound object into its component objects
EXPORT	Saves objects to other file formats
EXTEND	Extends an object to meet another object
EXTRUDE	Creates unique solid primitives by extruding existing two-dimensional objects
FILLET	Rounds and fillets the edges of objects
GRID	Displays a dot grid in the current viewport
GROUP	Creates a named selection set of objects
HATCH	Fills a specified boundary with a pattern

VIVA – VOCE

PRE LAB

1. List out the types of building symbols.
2. What are all the basic kinds of building?
3. What kinds of doors are available in buildings?
4. What is footing?
5. Define PCC and RCC

POST LAB

- 6) How to fix scale for a building.
- 7) Mention the dimension of title block
- 8) Write the dimension of A1,A2,A3,A4 Drawing sheets
- 9) What is section plane?
- 10) What is plinth level?

RESULT:

The study of basic commands used in the AutoCAD and able to draft the plan, section, elevation of a structure using these commands.

India NRI Institute of Technology
 पंकज कुमार पुरवा
 Dr. Pankaj Kumar Porwal
 (Principal)

Exp No.:

Date:

2. PRINCIPLES OF PLANNING, ORIENTATION AND COMPLETE JOINERY DETAILS (PANELED AND GLAZED DOORS AND WINDOWS)

AIM

To draw a paneled and glazed doors and windows using basic AutoCAD commands

OBJECTIVE

To introduce the students to draft the paneled and glazed doors and windows using accordance with development and control rules satisfying orientation and functional requirements as per National Building Code.

KEYWORDS:

Auto Cad Software

THEORY

CAD means Computer Aided Design or Drafting. Auto cad is most widely used software developed by auto desk. Auto cad is a drafting package in almost all engineering branches. There are drafting packages like cad are DIAP, CAMD, and Delights. Auto cad is one of the most popular cad packages. It is a general purpose computer aided design. We can draw geometrical entries like plan, section and elevation of a building.

- We can make accurate drawings like plan, section and elevation of a building.
- Improved engineering productively
- Reduced engineering personal requirement.
- Drawing modification or eraser to intake.
- Drawings prepared in the software can be stored safely.

EXPERIMENTAL PROCEDURE

STEP 1

Plan aspect of residential building:

The planning of residential buildings requires careful considerations on the part of the architect.

The barest requirements for a family unit are living room, kitchen, bath and w.c. But for the purpose of discussion, the usual requirements of a normal residential unit can be mentioned as follows:

- (1) Bath and w.c.
- (2) Bed room

For Techno India NJR Institute of Technology
पंकज पोखवाल
Dr. Pankaj Kumar Porwal
(Principal)

- (3) Dining room
- (4) Drawing room
- (5) Garage
- (6) Kitchen
- (7) Living room
- (8) Open chowk
- (9) Passages
- (10) Stair
- (11) Store
- (12) Verandah

STEP 2

Planning aspects of industrial structures:

Following are the factors which are to be considered while planning the industrial structures:

- (1) Functional aspect
- (2) Lighting
- (3) Materials of construction
- (4) Mechanical layout
- (5) Number of floors
- (6) Site conditions
- (7) Ventilation

STEP 3

Requirements of big industrial units :

The size of industrial unit is generally decided by the number of workers or labourers employed by the unit and accordingly, the industrial unit is required to provide various facilities for the smooth functioning of the industrial concern. Following are the requirements of big industrial units:

- (1) Canteen
- (2) Cloak-room
- (3) Drinking water
- (4) Entrance
- (5) Loading and unloading platform
- (6) Medical aid
- (7) Office
- (8) Sanitary block

For Technical India NIT Institute of Technology
पंकज पोखवाल
Dr. Pankaj Kumar Porwal
(Principal)

(9) Storage

Principles underlying building bye-laws:

The broad principles to be observed while framing the building bye-laws.

(1) Permissible size of plots:

The minimum size of plot required for each family unit shall be as follows:

170m² for one family unit

300 m² for two semi-detached family units

670 m² for ownership flats.

(2) Margins:

The margins on road side and adjacent properties shall be respectively 4.50 m and 3.00 m.

For plots having areas less than 300m², they shall be respectively 3.00m and 2.00 m.

(3) Area of rooms:

Table shows the minimum areas of various rooms.

Sl. No.	Use of room	Minimum area	Remarks
1.	Living room, Bed room, Drawing room, Sitting room, Ladies room, Dining room, Study room	9m ²	No side to be less than 2.40m
2.	Store room, Kitchen	5.40 m ²	No side to be less than 1.80m
3.	Bath room, Dressing room, Pump room, Water room, Coal room	Minimum 1.35 m ² and max. 4.50 m ²	No side to be less than 90cm.
4	W.C., Urinal	0.81m ²	No side to be less than 90cm.

(5) Plinth height:

It shall be 45cm above road level or plot level, whichever is higher.

(6) Height of floors:

The minimum heights shall be as follows:

2.10m: Bath room, w.c., pump room, coal room and water room.

2.70m: Floor height on each floor

The maximum height of floors shall not be more than 1.25 times the minimum height.

(7) Projections in margins:

Following projections in marginal spaces shall be permitted:

(i) Canopy of 3.00m width above 2.40m from ground level;

(ii) Gallery of maximum width 1.20m at floor levels.

(iii) Stair attached to building and open to sky with minimum width of 90cm; and

(iv) Weather-shed of maximum width 50cm at level level

(8) Cellar:

The permission to construct cellar shall be granted with the following restrictions:

Height	: 2.40m
Stair width	: 90cm
Ventilation	: One-tenth of floor area
Water and drainage connection:	Not allowed
Use	: For storage only
Maximum area	: One-half of built-up area of G.F

(9) Loft:

The provision of loft shall be permitted in kitchen and store. The maximum width of loft shall be one-third the width in that direction. The maximum height above loft shall be 1.50m and bottom of loft shall be at a minimum height of 2.10m from floor level.

(10) Lift:

For buildings having more than three floors (exclusive of ground floor), lift shall be provided at the rate of one lift for 20 family units or part thereof. The lift shall be provided from ground floor and its minimum capacity shall be of 6 persons.

(11) Ventilation:

All rooms except coal room, water room, store room and garage shall have atleast one side adjacent to open space. Area of windows and ventilators excluding frames shall be atleast one-tenth of the floor area of room.

(12) Stair:

The minimum width of stair shall be 90 cm and it shall be made of fire-proof construction. The pitch of stair shall be within 30 to 45. The stair cabin shall not exceed 11m² in area

(14) Joinery Details

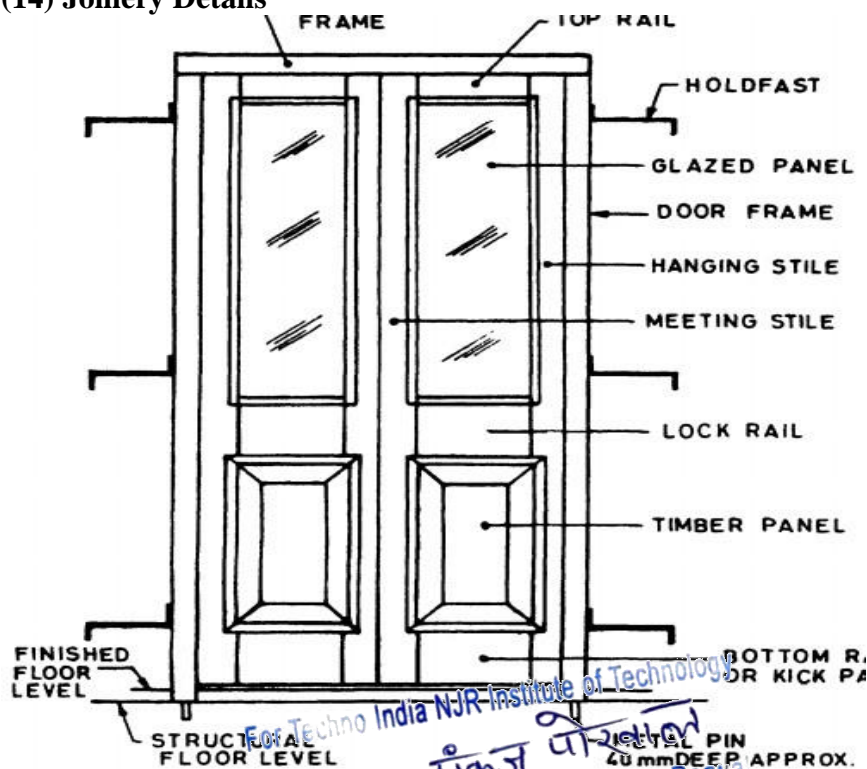

FIG. 1 TYPICAL ILLUSTRATION OF DOUBLE PANEL DOOR WITH TIMBER AND GLAZED PANELS

VIVA – VOCE

PRE LAB

1. List out the commands involved in modify tool bar.
2. Why do we use mirror ?
3. List out the commands involved arc tool bar.
4. Define plan of the building.
5. How to obtain section from plan?

POST LAB

1. How to obtain elevation?
- 2) How will you modify text command?
- 3) What is the purpose of using hatch command?.
- 4) What is the height of sill level?
- 5) What is load bearing structure?.

RESULT:

The paneled and glazed doors and windows are drawn successfully using basic AutoCAD commands

For Techno India NJR Institute of Technology
पंकज पोरवाल
Dr. Pankaj Kumar Porwal
(Principal)

Exp No.:

Date:

3. A READING ROOM WITH R.C.C FLAT ROOF

Aim:

To draw a reading room with R.C.C flat roof using Auto CAD with suitable scale the following views with complete dimensions and details.

1. Plan at window sill level.
2. Section on AB.
3. Front elevation.

OBJECTIVE

To introduce the students to draft the plan, elevation and sectional views of RCC buildings in accordance with development and control rules satisfying orientation and functional requirements as per National Building Code.

KEYWORDS:

Auto Cad Software

THEORY

CAD means Computer Aided Design or Drafting. Auto cad is most widely used software developed by auto desk. Auto cad is a drafting package in almost all engineering branches. There are drafting packages like cad are DIAP, CAMD, and Delights. Auto cad is one of the most popular cad packages. It is a general purpose computer aided design. We can draw geometrical entries like plan, section and elevation of a building.

- We can make accurate drawings like plan, section and elevation of a building.
- Improved engineering productively
- Reduced engineering personal requirement.
- Drawing modification or eraser to intake.
- Drawings prepared in the software can be stored safely.

EXPERIMENTAL PROCEDURE

Specifications:

The following specifications correspond to the line plan of the reading room with R.C.C flat roof.

1. Foundation:

The foundation for all main walls will be in cement concrete 1:4:8, 600 wide and 200 thick laid at 600 below ground level. The masonry footing will be in RR masonry in CM 1:5, the first footing being 400x400 for all walls.

2. Basement:

The basement will be in RR masonry in CM 1:5, 200 wide 300 thick above G.L for all walls and is filled with clean sand to a depth of 150. A D.P.C in CM 1:3, 20 thick will be provided for all walls at basement level.

3. Super structure:

All walls will be in B.W in CM 1:5, using 1st class B.W, 200 thick. The height of all walls will be 3000 above F.L. All walls including basement will be plastered smooth and CM 1:4 externally and 1:6 internally for 12.5 thick. Parapet walls, 200 thick and 450 high will be provided all round.

4. Roofing:

The roofing will be of R.C.C 1:2:4 mix , 100 thick flat slab over the room. A weathering course in brick jelly lime concrete 1:5:9 mix plastered with combination mortar 75 thick over the slab.

5. Doors, windows :

D- Flush door : 1500 into 2100

W-Window paneled : 1200x1200

6. Lintel:

All internal wall openings will be provided with R.C.C lintels, 1:1.5:3 mix; 150 thick. All external openings will be provided with R.C.C lintel – cum-sunshade, 1:1.5:3 mix, 600 wide and 50 thick.

7. Flooring:

The flooring will be in CC 1:4:8, 130 thick and plastered smooth with CM 1:3, 20 thick.

8. Steps:

Steps will be in brick walk in CM 1:5 laid on a 1800 x450 x150 thick CC 1:4:8 footing. Rise 150, Tread 300.

Note:

1. Any other dimensions found necessary may be assumed suitably making clear indications of the same.
2. All dimensions indicated are in millimeter.

PRODUCED BY AN AUTODESK EDUCATIONAL PRODUCT

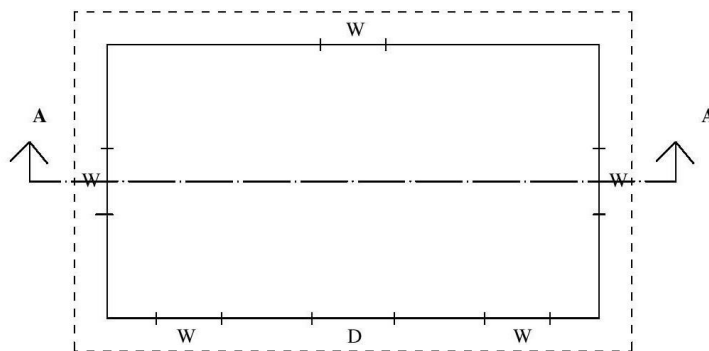

LINE PLAN

REFERENCE

Type	Description	Size
D	Door	1500 x 2100
W	Window	1200 x 1200
Steps		
	Rise	150
	Tread	300

PRODUCED BY AN AUTODESK EDUCATIONAL PRODUCT

ALL DIMENSIONS ARE IN mm

For Techno India NJR Institute of Technology
 पंकज पोखवाल
 Dr. Pankaj Kumar Porwal
 (Principal)

VIVA – VOCE

PRE LAB

1. What are all the steps involved in site clearance?
- 2 How will you mark a site for setting out a foundation?
- 3 Define the term masonry.
- 4 Explain the sequence of operation in construction with an example.
- 5 What is composite masonry?

POST LAB

- 1 What are all the types of ashlar masonry?
- 2) Differentiate English bond and Flemish bond.
- 3) Write notes on zig-zag bond
- 4) Write notes on temporary shed
- 5) What are all the types of scaffolding?

RESULT:

The reading room with R.C.C flat roof are drawn successfully using AutoCAD commands

For Techno India NJR Institute of Technology
पंकज पोखवाल
Dr. Pankaj Kumar Porwal
(Principal)

Exp No.:

Date:

4. A RESIDENTIAL BUILDING WITH SINGLE BED ROOM

Aim:

To draw the following views with complete dimension for a residential building with single bed room (R.C.C flat roof)

1. Plan at window sill level.
2. Section on ABCD.
3. Front elevation.

OBJECTIVE

To introduce the students to draft the plan, elevation and sectional views of residential building with single bed room buildings in accordance with development and control rules satisfying orientation and functional requirements as per National Building Code.

KEYWORDS:

Auto Cad Software

THEORY

CAD means Computer Aided Design or Drafting. Auto cad is most widely used software developed by auto desk. Auto cad is a drafting package in almost all engineering branches. There are drafting packages like cad are DIAP, CAMD, and Delights. Auto cad is one of the most popular cad packages. It is a general purpose computer aided design. We can draw geometrical entries like plan, section and elevation of a building.

- We can make accurate drawings like plan, section and elevation of a building.
- Improved engineering productively
- Reduced engineering personal requirement.
- Drawing modification or eraser to intake.
- Drawings prepared in the software can be stored safely.

EXPERIMENTAL PROCEDURE

Specifications:

The following specifications correspond to the line plan of a house with single bed room and attached bathroom with R.C.C flat roof.

For Techno India NJR Institute of Technology
Dr. Pankaj Kumar Poddar
(Principal)

1. Foundation:

The foundation for all main walls and verandah retaining walls will be CC 1:4:8 mix, 1000 wide and 200 thick laid at 1100 below ground level. The masonry footing will be in BW in CM 1:6, the 1st footing being 700x400 and the 2nd being 400 x 500 for all walls and verandah retaining walls.

2. Basement:

The basement will be in BW in CM 1:6, 200 wide and 600 high above GL for all main walls and verandah retaining walls is filled with clean sand to a depth of 450. A D.P.C in CM 1:3, 20 thick will be provided for all walls at basement level.

3. Super structure:

All walls will be in B.W in CM 1:5, using 1st class B.W, 200 thick. The height of all walls will be 3000 above F.L. the height of roof at verandah portion will be 2700. The partition wall in WC and bath 100 thick in BW in CM 1:5 using country bricks and carried up to a height of 2100. One brick pillar 200x400 will be provided in the verandah. All walls including basement will be plastered smooth and CM 1:4 externally and 1:6 internally for 12.5 thick. Parapet walls, 200 thick and 600 high will be provided all round.

4. Roofing:

The roofing will be of R.C.C 1:1.5:3 mix, 125 thick flat slab over the rooms and the verandah. A weathering course, 75 thick consists of two course of flat tiles set in CM 1:3 mixed with crude oil will be provided with slab.

5. Doors, windows, etc.,:

- D1-panelled door :1100x 2100
- D2-panelled door :900x 2100
- W1-panelled Window :1200 x 1200
- W2-Glazed Window :1500 x 1200
- V1-Ventilator glazed :900 x 450
- V2-Ventilator glazed :1500 x 450
- J – R.C. Jolly : 2400 x 1200
- CB-cupboard: 300 depth
- S-shelf :200 depth

6. Lintel:

All internal wall openings will be provided with R.C.C lintels, 1:1.5:3 mix; 150 thick. All external openings will be provided with R.C.C lintel – cum-sunshade, 1:1.5:3 mix, 450 wide and 150 thick and 600 wide R.C.C lofts shall be provided in bed, kitchen and utility.

7. Flooring:

The flooring will be in CC 1:4:8, 130 thick and plastered smooth with CM 1:3, 20 thick.

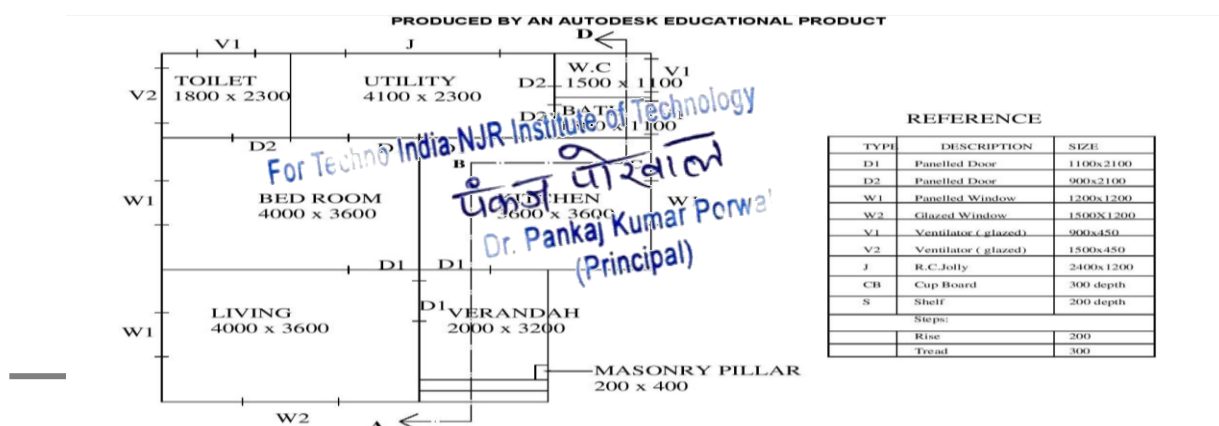

A RESIDENTIAL BUILDING WITH SINGLE BED ROOM

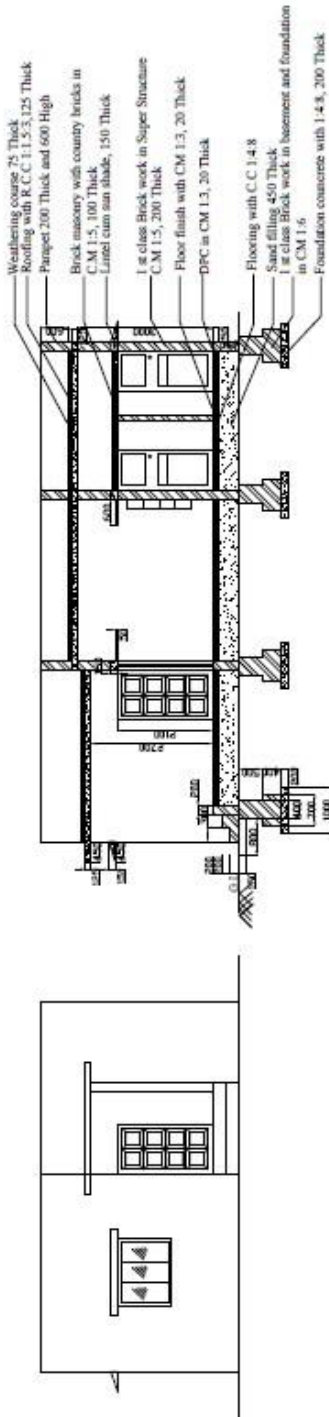

ELEVATION

SECTION ABCD

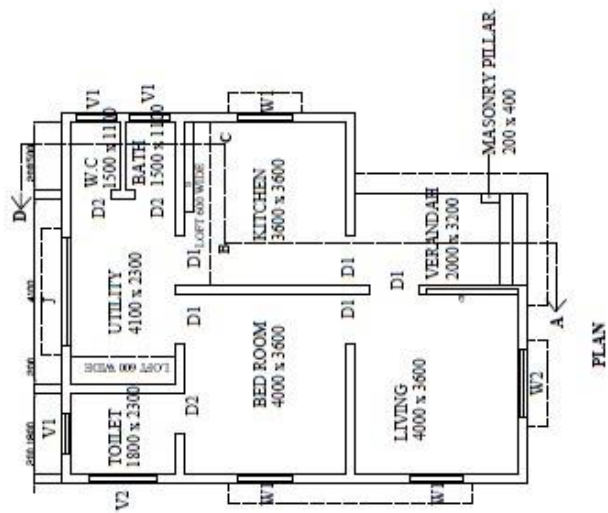

PLAN

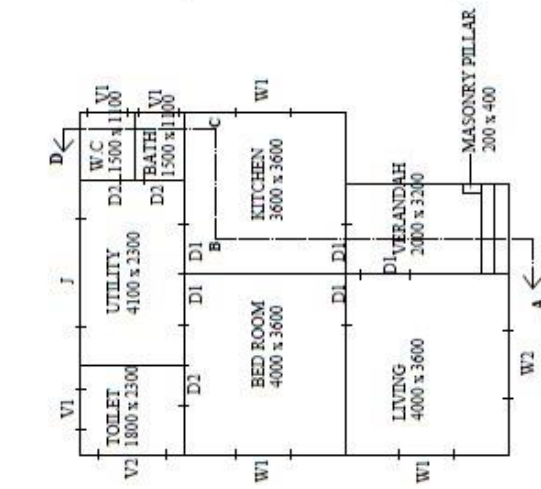

LINE PLAN

ALL DIMENSIONS ARE IN mm

REFERENCE

TYPE	IS CODE/SP/PS/IS	ISSE
D1	Standard Door	1100x2100
D2	Standard Door	900x2100
W1	Standard Window	2000x1200
W2	Standard Window	1500x1200
V1	Standard Verandah	4000x3600
V2	Standard Verandah	1500x1100
J	R.C.C. Joist	200x200x200
CB	One Board	100 depth
S	Slab	200 depth
	Steps	
	Rise	200
	Going	300

For Techno India NJR Institute of Technology
 पंकज पोखवाल
 Dr. Pankaj Kumar Porwal
 (Principal)