

Techno India NJR Institute of Technology

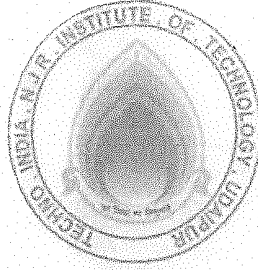

Course File
Information Theory & Coding
(5CS 3-01)

Vivek Jain
(Associate Professor)
Department of ECE

For Techno India NJR Institute of Technology
पंकज पोरवाल
Dr. Pankaj Kumar Porwal
(Principal)



RAJASTHAN TECHNICAL UNIVERSITY, KOTA

Syllabus

III Year-V Semester: B.Tech. Computer Science and Engineering

SCSS-01: Information Theory & Coding

Credit: 2
2L+0T+0P

Max. Marks: 100(IA:20, ETE:80)
End Term Exam: 2 Hours

Sl#	Contents	Hours
1	Introduction: Objective, scope and outcome of the course.	01
2	Introduction to information theory: Uncertainty, Information and Entropy. Information measures for continuous random variables, source coding theorem. Discrete Memory less channels, Mutual information, Conditional entropy.	05
3	Source coding schemes for data compaction: Prefix code, Huffman code, Shannon-Fane code &Hempel-Ziv coding channel capacity. Channel coding theorem. Shannon limit.	05
4	Linear Block Code: Introduction to error correcting codes, coding & decoding of linear block code, minimum distance consideration, conversion of non-systematic form of matrices into systematic form.	05
5	Cyclic Code: Code Algebra, Basic properties of Galois fields (GF) polynomial operations over Galois fields, generating cyclic code by generating polynomial, parity check polynomial. Encoder & decoder for cyclic codes.	06
6	Convolutional Code: Convolutional encoders of different rates. Code Tree, Trellis and state diagram. Maximum likelihood decoding of convolutional code: The viterbi Algorithm for distance of a convolutional code.	06
	Total	28

For Techno India NJR Institute of Technology
पंकज कुमार
Dr. Pankaj Kumar Porwal
(Principal)

Course Overview:

Students undergoing this course are expected to: • Understand the basics of information theory and coding theories. decoding algorithm. Understand and explain the basic concepts of information theory, source coding, channel and channel capacity, channel coding and relation among them. Understand basic concepts of Error detection and correction code.

Course Outcomes:

CO.NO.	Cognitive Level	Course Outcome
1	Knowledge	Students will define and describe of entropy & Source coding.
2	Comprehension	Students able to distinguish and classify various source coding schemes for data compaction and compare source coding schemes on the basis of code efficiency.
3	Application	Students will apply concepts of block code on transmitting message compute number errors in receiving message.
4	Synthesis	Students will be able to design and develop encoder and decoder for cyclic code, linear block code, convolution code.
5	Evaluation	Students will be able interpret and predict correct receiving message using block codes.

Prerequisites:

1. Fundamentals knowledge of probability.
2. Fundamentals knowledge of sequential and combinational circuit.
3. Fundamentals knowledge of digital communication.

Course Outcome Mapping with Program Outcome:

Course Outcome	Program Outcomes (PO's)											
	Domain Specific					Domain Independent						
CO. NO.	PO1	PO2	PO3	PO4	PO5	PO6	PO7	PO8	PO9	PO10	PO11	PO12
CO1	3	3	2	3	1	1	1	0	0	0	0	0
CO2	3	3	1	3	1	1	1	0	0	0	0	0
CO3	3	3	1	2	1	1	1	0	0	0	0	0
CO4	3	3	1	2	1	1	1	0	0	0	0	0
CO5	3	3	1	3	1	1	1	0	0	0	0	0

1: Slight (Low) , 2: Moderate (Medium), 3: Substantial (High)

For Techno India NJR Institute of Technology
पंकज पौरवाल
Dr. Pankaj Kumar Porwal
(Principal)

Course Coverage Module Wise:

Lecture No.	Unit	Topic
1	1	INTRODUCTION: Objective, scope and outcome of the course.
2	2	BASICS OF INFORMATION THEORY
3	2	Uncertainty and Information
4	2	Average information, Entropy
5	2	Properties of Entropy
6	2	Numerical on Entropy
7	2	Information Rate
8	2	Numerical on Information Rate
9	2	Conditional And Joint Entropy
10	2	Numerical on Conditional And Joint Entropy
11	2	Mutual Information
12	2	Numerical on Mutual Information
13	2	Shannon's noiseless coding theorem: Huffman coding
14	2	Numerical on Huffman coding
15		Shannon's noiseless coding theorem: Shannon Fano coding
16	2	Numerical on Shannon Fano coding
17	3	DISCRETE MEMORY LESS CHANNEL
18	3	Numerical on memory less channel
19	3	Numerical on memory less channel
20	3	Binary Symmetric channel
21	3	Numerical on Binary Symmetric channel
22	3	Numerical on Binary Symmetric channel
23	3	Shannon's noisy coding theorem
24	3	Numerical on Shannon's noisy coding theorem
25	3	Numerical on Shannon's noisy coding theorem
26	3	Capacity of Gaussian Channel
27	3	Numerical on Capacity of Gaussian Channel

For Techno India NJR Institute of Technology
 पंकज कुमार
 Dr. Pankaj Kumar Porwal
 (Principal)

28	3	Numerical on Capacity of Gaussian Channel
29	3	Trade off between signal to noise ratio and bandwidth of channel
30	3	Numerical on Trade off between signal to noise ratio and bandwidth of channel
31	3	Numerical on Trade off between signal to noise ratio and bandwidth of channel
32	4	TECHNIQUES OF CODING AND DECODING
33	4	Introduction of Huffman codes
34	4	Introduction of uniquely detectable codes or Variable length codes
35	4	Introduction of prefix coding and Numerical
36	4	Introduction of Linear Block codes
37	4	Numerical on Linear Block codes
38	4	Introduction of Cyclic codes
39	4	Numerical on Cyclic codes
40	4	Introduction of Convolution arithmetic codes
41	4	Numerical on Convolution arithmetic codes

TEXT/REFERENCE BOOKS

1. Digital Communication, Simon Haykin, Wiley.
2. Information Theory & Coding, J.S.Chitode, Technical Publications.
3. Information Theory, Coding & Cryptography, Ranjan Bose, Mcgrahill, Education.

NPTEL COUSES LINK

For Techno India NJR Institute of Technology
 पंकज कुमार
 Dr. Pankaj Kumar Porwal
 (Principal)

1. nptel.ac.in/courses/108/102/108102117/
2. nptel.ac.in/courses/117/108/117108097/
3. nptel.ac.in/courses/117/101/117101053/

Faculty Notes Link

drive.google.com/drive/folders/1uNMfP3JbEcf673UY5n3ASrVhqYCUGjaV?usp=sharing

QUIZ Link

1. careerride.com/mcq-tagwise.aspx?Key=Information%2520Theory&Id=21
- 2.

edurev.in/subscription?catid=49&catname=GATE&course=7813&rufrom=q&rurl=course/quiz/7813-Test-Information-Theory-Coding/54f0f9c8-0a8d-4f85-9992-229e920ebe27?courseId=7813

Assessment Methodology:

1. Two Midterm exams where student have to showcase subjective learning.
2. Final Exam (subjective paper) at the end of the semester.

TECHNO INDIA NJR INSTITUTE OF TECHNOLOGY UDAIPUR

For Techno India NJR Institute of Technology
पंकज पोरवाल
Dr. Pankaj Kumar Porwal
(Principal)

Computer Science and Engineering
B. TECH III- YEAR (V Sem)
SUBJECT 5CS301
Information Theory & Coding

Assignment Sheet I

1. (a) Show that entropy H of M equally likely message is $\log_2 M$. (CO1)

(b) Prove that the following statement, "if the receiver knows the message being transmitted the amount of information carried is zero".

(c) Prove that the upper boundary on entropy is given as $H_{\max} \leq \log_2 M$ here 'M' is the number of message emitted by the source.

(d) Show that for a discrete binding channel:

(i) $H(X, Y) = H(X/Y) + H(Y)$

(ii) $I(X; Y) = H(X) - H(X/Y)$

2. (a) A binary channel matrix is given as : (CO1)

(10)

$$\begin{matrix} & 2/3 & 1/3 \\ 1/10 & & 9/10 \end{matrix}$$

$$\begin{matrix} 2/3 & 1/3 \\ 1/10 & 9/10 \end{matrix}$$

$P(x_1) = 1/3, P(x_2) = 2/3$

Determine

$H(X), H(X/Y), H(Y/X), I(X; Y), H(Y)$.

(b) An analog signal is band limited to B Hz and samples at Nyquist rate. The samples are quantized into 4 levels. Each level represents one message. Thus there are 4 messages. The probability of occurrence of these 4 levels are $p_1 = p_4 = 1/8$ and $p_2 = p_3 = 3/8$. Find out the information rate of source.

3. a) For a discrete memory less source 'X' with six symbols X_1, X_2, \dots, X_6 , find a compact code for every symbol if the probability distribution is as follows:- (CO2)

$P(X_1) = 0.3$

$P(X_2) = 0.25$

$P(X_3) = 0.2$

$P(X_4) = 0.12$

$P(X_5) = 0.08$

$P(X_6) = 0.05$

For Techno India NJR Institute of Technology
पंकज कुमार
Dr. Pankaj Kumar Porwal
(Principal)

Calculate entropy of the source , average length of the code, efficiency and redundancy of the code using Shannon-Fano algorithm and Huffman coding. Also compare both algorithm.

4. A) State and explain Shannon's theorem on the channel capacity . (CO2)

B) Channel capacity is given by $C=B \log_2(1+)$ bits/sec

In the above equation when the signal power is fixed and white Gaussian noise is present, the channel capacity approaches an upper limit with increase in bandwidth 'B' .Prove that this upper limit is given as ,

$$C_{\infty} = 1.44 =$$

C) Explain Prefix code. Write down the properties of prefix coding, explaining them with the help of an example. Give proof of the property required.

5. A) For a systematic LBC ,the three parity check digits C_4 , C_5 and C_6 are given by: (CO3)

$$C_4 = D_1 + D_2 + D_3$$

$$C_5 = D_1 + D_2$$

$$C_6 = D_1 + D_3$$

- i. Construct generator matrix.
- ii. Construct code generated by this matrix.
- iii. Determine error correcting capability.
- iv. Prepare a suitable decoding table.
- v. Decode the received words 101100 and 000110.
- vi. Draw the encoder arrangement for the same.

6. Write the short notes on (CO3)

- Syndrom calculator
- Conversion of non systematic form into systematic form
- Linear block coder
- Linear block code

TECHNO INDIA NJR INSTITUTE OF TECHNOLOGY UDAIPUR

For Techno India NJR Institute of Technology
पंकज पौरवाल
Dr. Pankaj Kumar Porwal
(Principal)

Computer Science and Engineering

B. TECH III- YEAR (V Sem)

SUBJECT 5CS301

Information Theory & Coding

Assignment Sheet II

- (a) The generator polynomial of a (7,4) cyclic code is $G(p)=p^3+p+1$. Find all the code vectors and Generator matrix for the code systematic form of cyclic code.
(b) Explain the irreducible polynomial over Galois field with one example. (CO4)
- (a) The generator polynomial of a (7,4) cyclic code is $G(p)=p^3+p+1$. Find all the code vectors and Generator matrix for the code nonsystematic form of cyclic code. (CO4)
- Explain the primitive polynomial over Galois field with one example. (CO4)
- (a) For the convolution encoder with constraint length of 3 and rate $\frac{1}{2}$ as shown below

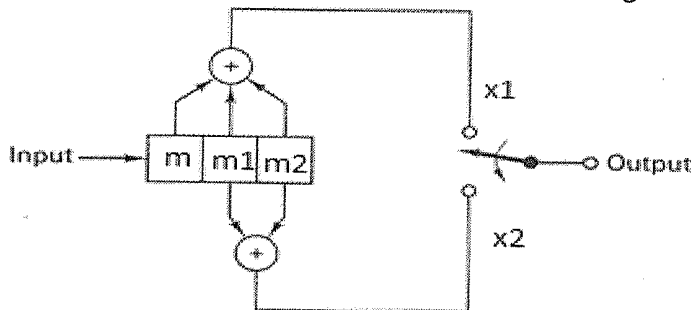

Find Out:

- Code rate (1)
 - Dimension of encoder (1)
 - Constraint length (1)
 - Generating Sequence (1)
 - Output Sequence for message sequence of $m=(10011)$ (CO5)
5. Explain the Viterbi Decoding or maximum Likelihood decoding with example. (CO5)

For Techno India NJR Institute of Technology
पंकज पोरवाल
Dr. Pankaj Kumar Porwal
(Principal)

6. For the convolution encoder with constraint length of 3 and rate $\frac{1}{2}$ as shown below (CO5)

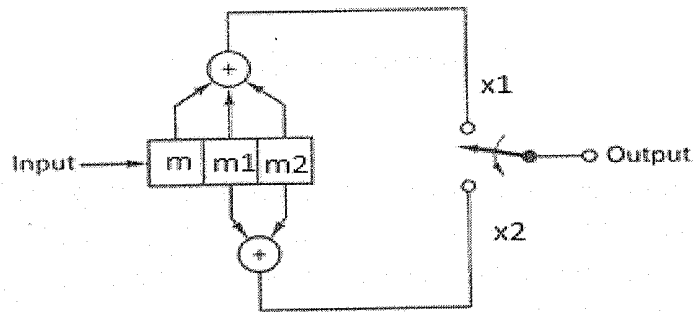

Draw the tree diagram state diagram and trellis diagram.

TECHNO INDIA NJR INSTITUTE OF TECHNOLOGY UDAIPUR

Computer Science and Engineering

B. TECH III- YEAR (V Sem)

SUBJECT 5CS301

Information Theory & Coding

VIVA-VOCE SET OF QUESTIONS

1. What is entropy?
2. What is channel redundancy?
3. Name the two source coding techniques.
4. Write the expression for code efficiency in terms of entropy.
5. What is memory less source? Give an example.
6. Explain the significance of the entropy $H(X/Y)$ of a communication system where X is the transmitter and Y is the receiver.
7. What is prefix code?
8. Define information rate.
9. Calculate the entropy of source with a symbol set containing 64 symbols each with a probability $p_i = 1/64$.
10. State the channel coding theorem for a discrete memory less channel.

Statement of the theorem:

11. What is information theory?
12. Explain Shannon-Fano coding.
13. Define bandwidth efficiency.
14. Define channel capacity of the discrete memory less channel.
15. What is the meaning of word 'Information' ?

For Techno India NJR Institute of Technology
पंकज पौरवाल
Dr. Pankaj Kumar Porwal
(Principal)

16. What are Information Source ? Explain .
17. Define the information content of a symbol.
18. What do you mean by Information rate ? Explain .
19. What is a Discrete Memoryless Channel (DMC) ? Explain .
20. State the channel coding theorem for a discrete memoryless channel.
21. Define channel capacity of the discrete memoryless channel.
22. Define mutual information.
23. State its two properties of mutual information.
24. Define efficiency of the source encoder.
25. Define code redundancy.
26. Define rate of information transmission across the channel.
27. Define bandwidth efficiency.
28. What is the capacity of the channel having infinite bandwidth?
29. Find entropy of a source emitting symbols x, y, z with probabilities of 1/5, 1/2, 1/3 respectively.
30. An alphabet set contains 3 letters A, B, C transmitted with probabilities of 1/3, 1/4, 1/4. Find entropy.
31. What are the property of Properties of entropy.
32. Define code variance
33. What is hamming distance?
34. What is meant by systematic and non systematic codes?
35. What are the error detection and correction capabilities of Hamming codes?
36. What is meant by linear code?

37. What is meant by cyclic code?
38. How syndrome is calculated in Hamming codes and cyclic codes?
39. What is the difference between block codes and convolutional codes?
40. Define constraint length in convolutional codes.
41. Define free distance and coding gain.
42. Why cyclic codes are extremely well suited for error detection?
43. What is syndrome?
44. Write syndrome properties of linear block codes.
45. What is Hamming code? Write its conditions
46. List the properties of generator polynomial of cyclic codes.
47. What is a valid Galois field?
48. What is GF 28 polynomial used in AES?
49. How is Galois field calculated?
50. What is the Galois group of a polynomial?

TECHNO INDIA NJR INSTITUTE OF TECHNOLOGY UDAIPUR

Computer Science and Engineering

B. TECH III- YEAR (V Sem)

SUBJECT 5CS301

Information Theory & Coding

QUIZ

1) The probability density function of a Markov process is

- a. $p(x_1, x_2, x_3, \dots, x_n) = p(x_1)p(x_2/x_1)p(x_3/x_2) \dots p(x_n/x_{n-1})$
- b. $p(x_1, x_2, x_3, \dots, x_n) = p(x_1)p(x_1/x_2)p(x_2/x_3) \dots p(x_{n-1}/x_n)$
- c. $p(x_1, x_2, x_3, \dots, x_n) = p(x_1)p(x_2)p(x_3) \dots p(x_n)$
- d. $p(x_1, x_2, x_3, \dots, x_n) = p(x_1)p(x_2 * x_1)p(x_3 * x_2) \dots p(x_n * x_{n-1})$

2) The capacity of Gaussian channel is

- a. $C = 2B(1+S/N)$ bits/s
- b. $C = B^2(1+S/N)$ bits/s
- c. $C = B(1+S/N)$ bits/s
- d. $C = B(1+S/N)^2$ bits/s

3) For M equally likely messages, the average amount of information H is

- a. $H = \log_{10}M$
- b. $H = \log_2M$
- c. $H = \log_{10}M^2$
- d. $H = 2\log_{10}M$

4) The channel capacity is

- a. The maximum information transmitted by one symbol over the channel
- b. Information contained in a signal
- c. The amplitude of the modulated signal
- d. All of the above

For Techno India NJR Institute of Technology
पंकज पौरवाल
Dr. Pankaj Kumar Porwal
(Principal)

5) The capacity of a binary symmetric channel, given $H(P)$ is binary entropy function is

- a. $1 - H(P)$
- b. $H(P) - 1$
- c. $1 - H(P)^2$
- d. $H(P)^2 - 1$

6) According to Shannon Hartley theorem,

- a. The channel capacity becomes infinite with infinite bandwidth
- b. The channel capacity does not become infinite with infinite bandwidth
- c. Has a tradeoff between bandwidth and Signal to noise ratio
- d. Both b and c are correct

7) The negative statement for Shannon's theorem states that

- a. If $R > C$, the error probability increases towards Unity
- b. If $R < C$, the error probability is very small
- c. Both a & b
- d. None of the above

8) For M equally likely messages, $M \gg 1$, if the rate of information $R \leq C$, the probability of error is

- a. Arbitrarily small
- b. Close to unity
- c. Not predictable
- d. Unknown

9) For M equally likely messages, $M \gg 1$, if the rate of information $R > C$, the probability of error is

- a. Arbitrarily small
- b. Close to unity
- c. Not predictable
- d. Unknown

10) The channel capacity according to Shannon's equation is

- a. Maximum error free communication
- b. Defined for optimum system
- c. Information transmitted
- d. All of the above

For Techno India NJR Institute of Technology
पंकज पौरवाल
Dr. Pankaj Kumar Porwal
(Principal)

11) For a binary symmetric channel, the random bits are given as

- a. Logic 1 given by probability P and logic 0 by $(1-P)$
- b. Logic 1 given by probability $1-P$ and logic 0 by P
- c. Logic 1 given by probability P^2 and logic 0 by $1-P$
- d. Logic 1 given by probability P and logic 0 by $(1-P)^2$

12) The technique that may be used to increase average information per bit is

- a. Shannon-Fano algorithm
- b. ASK
- c. FSK
- d. Digital modulation techniques

13) Code rate r , k information bits and n as total bits, is defined as

- a. $r = k/n$
- b. $k = n/r$
- c. $r = k * n$
- d. $n = r * k$

14) The information rate R for given average information $H = 2.0$ for analog signal band limited to B Hz is

- a. $8B$ bits/sec
- b. $4B$ bits/sec
- c. $2B$ bits/sec
- d. $16B$ bits/sec

15) Information rate is defined as

- a. Information per unit time
- b. Average number of bits of information per second
- c. rH
- d. All of the above

16) The mutual information

- a. Is symmetric
- b. Always non negative
- c. Both a and b are correct
- d. None of the above

For Techno India NJR Institute of Technology
पंकज पौरवाल
Dr. Pankaj Kumar Porwal
(Principal)

17) The relation between entropy and mutual information is

- a. $I(X;Y) = H(X) - H(X/Y)$
- b. $I(X;Y) = H(X/Y) - H(Y/X)$
- c. $I(X;Y) = H(X) - H(Y)$
- d. $I(X;Y) = H(Y) - H(X)$

18) Entropy is

- a. Average information per message
- b. Information in a signal
- c. Amplitude of signal
- d. All of the above

19) The memory less source refers to

- a. No previous information
- b. No message storage
- c. Emitted message is independent of previous message
- d. None of the above

20) The information I contained in a message with probability of occurrence is given by (k is constant)

- a. $I = k \log_2 1/P$
- b. $I = k \log_2 P$
- c. $I = k \log_2 1/2P$
- d. $I = k \log_2 1/P^2$

QUIZ ANSWER KEY

Q1. A Q2. C Q3. B Q4. A Q5. A Q6. D Q7. A Q8. A Q9. B Q10. D
Q11. A Q12. A Q13. A Q14. B Q15. D Q16. C Q17. B Q18. A Q19. C Q20. A

For Techno India NJR Institute of Technology
पंकज पौरवाल
Dr. Pankaj Kumar Porwal
(Principal)

TECHNO INDIA NJR INSTITUTE OF TECHNOLOGY UDAIPUR

Computer Science and Engineering

B. TECH III- YEAR (V Sem)

SUBJECT 5CS301

Information Theory & Coding

RTU Question Paper

Instructions to Candidates:

Attempt all five questions from Part A, four questions out of six questions from Part B and one questions out of three from Part C.

Schematic diagrams must be shown wherever necessary. Any data you feel missing may suitably be assumed and stated clearly. Units of quantities used/calculated must be stated clearly.

*Use of following supporting material is permitted during examination.
(Mentioned in form No. 205)*

1. NIL

2. NIL

PART - A

(Answer should be given up to 25 words only)

[5×2=10]

All questions are compulsory

- Q.1 State the channel coding theorem for a discrete memoryless channel.
- Q.2 What is prefix coding?
- Q.3 Explain channel capacity theorem.
- Q.4 Define efficiency of the source encoder.
- Q.5 Define mutual information.

For Techno India NJR Institute of Technology
पंकज पोरवाल
Dr. Pankaj Kumar Porwal
(Principal)

PART - B

(Analytical/Problem solving questions)

[4×10=40]

Attempt any four questions

- Q.1 An alphabet set contains 3 letters A, B, C transmitted with probabilities of 1/3, 1/4, 1/4. Find entropy.
- Q.2 What is the difference between block codes and convolutional codes?
- Q.3 Show that for a discrete binding channel -
 $H(x, y) = H(x/y) + H(y)$
 $H(x, y) = H(x) + H(y)$
- Q.4 Write short note on Noise free channel and Shannon's theorem.
- Q.5 Consider a source $S = [S_1, S_2]$ with probabilities 3/4 and 1/4 respectively. Obtain Shannon - Fane code for source S its 2nd and 3rd extensions. Calculate efficiency for each case.
- Q.6 What is coding efficiency? Show that coding efficiency is maximum when $P(0) = P(1)$.

PART - C

(Descriptive/Analytical/Problem Solving/Design Questions)

[1×15=15]

Attempt any one questions

- Q.1 The intersection of cyclic codes is cyclic. Find the generator polynomial of $C_1 \cap C_2$.
- Q.2 Explain the need of error correcting codes. How its Encoding/Decoding take place? Explain with help of parity example.
- Q.3 Write short notes (any two) -
(a) Hamming code and their applications
(b) Fading channel
(c) Huffman coding
(d) Advantages and disadvantages of convolutional codes

For Techno India NJR Institute of Technology
पंकज पोखवाल
Dr. Pankaj Kumar Porwal
(Principal)

For Techno India NJR Institute of Technology
पंकज पोखवाल
Dr. Pankaj Kumar Porwal
(Principal)