

“DESIGN AND MANUFACTURING OF MODIFIED ANGLE JIG TOOL”

ABHIJIT TAGADE¹, NILESH NIRWAN², MANISH MISHRA³

¹. M.Tech student, Wainganga college of engineering, Nagpur (India)

². Faculty, Wainganga college of engineering, Nagpur (India)

³. Sr. Engineer, Indo German Tool Room, Nagpur (India)

Abstract - To face challenges industries needs to increase their production rate with good quality product, achieving production in time. This project is proposed method to design modified angle jig for the drilling holes on given component. Thus the time required for the production of component should be decreased to as small as possible with the help of these jig. The marking time, loading and unloading time can be get minimise with reduction in rejection, and cost effectiveness tool. In this paper we starts from basic conceptual design of jig and comes up with this model which can satisfy theoretical concepts of jig design. The 3D model design done on Solidworks & 2D drafting carried on using AutoCAD.

KeyWords - TOOL DESIGN, JIG DESIGN, CAD, SOLIDWORKS, ELEMENTS, ASSEMBLY

1. INTRODUCTION-

In industries, Production of quality goods in large quantities at high speeds is the requirement of these days. To meet this, there have been considerable changes and development in the manufacturing industries with an emphasis on increased efficiency and productivity. The jigs & fixtures are economical means to produce repetitive type of work.

1.1 Drill Jig-

Jig is device which holds workpiece & locates or guides the tool relative to the work piece and usually which is not fixed to the machine table. It is normally lightly in construction. Jigs are further identified by their basic construction. The most-common open jigs are template jigs, plate jigs, table jigs, sandwich jigs, and angle plate jigs. Typical examples of closed jigs include box jigs, channel jigs, and leaf jigs. As a result jigs are eliminates the marking out, measuring, and other setting methods before doing machining.

Drill jigs are used for drilling holes which must be accurately located, both in relation to each other & to certain working surfaces and points; the location of the holes is governed by

holes in the jig through which the drill passes. The essential features of jigs and features include:

- ✓ Clamps position
- ✓ Neatness of work-piece
- ✓ Standardization
- ✓ Idle time reduction
- ✓ Set up time reduction
- ✓ Hardened surface

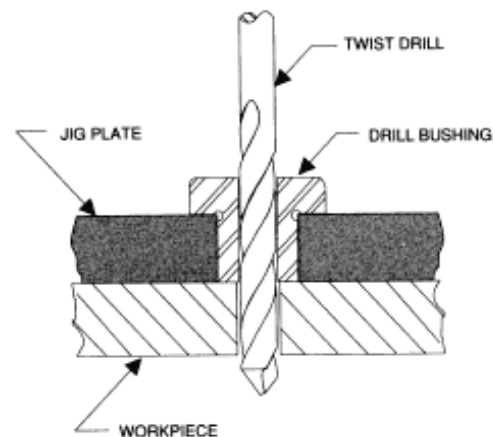

Fig-1: jig guides the tool, with a bushing.

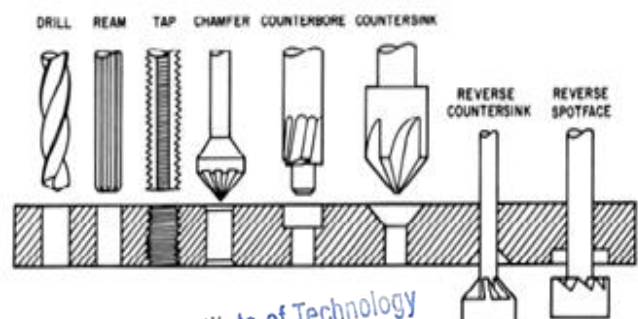

Fig-2: various operations

For Techno India NJR Institute of Technology
 पंकज पुराण
 Dr. Pankaj Kumar Porwal
 (Principal)

1.2 Fixtures-

A fixture is a work holding device which holds work piece during inspection or manufacturing, but does not itself guide locates or positions the cutting tool.

1.3 Jigs and fixtures useful for following factors-

- 1) Help to increase productivity.
- 2) It Ensures interchangeability & high accuracy of parts.
- 3) It Reduces need for inspection & quality control Expenses on workpiece.
- 4) Minimise the risk of accidents & improve the safety.
- 5) Semi-skilled machine operators can easily use them thereby it can save the cost of manpower.
- 6) Complex and heavy components can be easily machined.
- 7) Easy assembly operations save labour & also lead to reduction of defective products.
- 8) They eliminate the need for measuring, marking out, positioning, alignments & setting up.
- 9) Increases technological capacities of machine tools.
- 10) The application of more than one tool simultaneously on a work-piece can be achieved.

1.4 Application of jigs & fixtures-

- ✓ It used in automobile industries.
- ✓ It used in aircraft industries.
- ✓ Fixtures used in numerically controlled machine tools.
- ✓ Other application of jigs and fixtures (Plastic, textiles, consumer product industries)

Table 1 CAD tool required to support the design process

DESIGN PHASE	CAD TOOLS
Concept design	Geometric modeling techniques, graphic aids and manipulations
Design modelling & simulation	Same as above, animation, assemblies, special modelling packages
Design analysis	Analysis packages, customized programs and packages
Design optimization	Customized applications structural optimization
Design evaluation	Dimensions, tolerances, bill of material
Design communication and documentation	Drafting, detailing

Table 2 Difference between Jig & Fixtures-

BASIC	JIGS	FIXTURES
Definition	It's a work holding device & locates workpiece and guides the tool.	Fixtures only locates & holds The work piece.
Clamping requirements	Jigs are not clamped to the drill table unless and until large diameter holes are to be drilled. Also there is necessity to move the jig to bring one bush directly under the drill.	Fixtures should be securely clamped to the table of the machine upon which the work needs to be done. Also there is no requirement of alignment as bush is absent in fixture.
Operation performed	Jigs are special tools which used in operation like reaming, tapping and boring.	Fixtures are used in milling & similar operations.
Weight of tool	Jigs are generally lighter in construction.	Fixtures are usually heavier in construction

2. COMPONENT DETAILS

As below shown component in fig. 4 need to drill hole of 10 mm which was not possible to make in casting.

- ✓ Material – Cast carbon steel
- ✓ Density = 0.01 grams per cubic millimeter
- ✓ Mass = 1177.97 grams
- ✓ Volume = 151021.43 cubic millimeters
- ✓ Surface area = 39832.84 square millimeters
- ✓ Center of mass: (millimeters)
X = 14.22, Y = -48.59, Z = 0.00

For Techno India NJR Institute of Technology
 पंकज पौरवाल
 Dr. Pankaj Kumar Porwal
 (Principal)

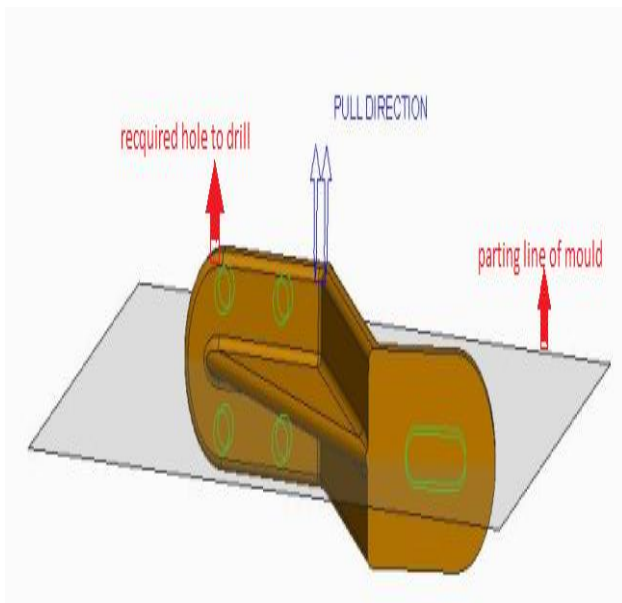

Fig-3: core & cavity extraction

- ✓ Designer should have clear understanding of product details.
Eg- pre-machined conditions, dimensions, accuracies and tolerances.
- ✓ Designer should know about machine on which operations going to performed.
- ✓ Quick & accurate positioning of work piece facilities should be provided.
- ✓ Easy provision of loading & unloading.
- ✓ If the surface area of clamping is more it damages the work piece. This can be avoided by making the surface area of clamping as small as possible.
- ✓ To avoid wrong positioning of workpiece fool proof method should be used.
- ✓ The movement of the workpiece is restricted. There is zero degree of freedom of the workpiece after clamping the workpiece.
- ✓ Sharp corners and redundant locators must be avoided. One should try to maintain at least one datum surface.
- ✓ Care has to be taken by providing workpiece suitable support for preventing it from bending.
- ✓ Drawing should have provided with proper engineering data.
- ✓ Minimum cost should be incurred during the fabrication of the project and the design should be as simple as possible. In such a way it will help even a lay man to operate the device.

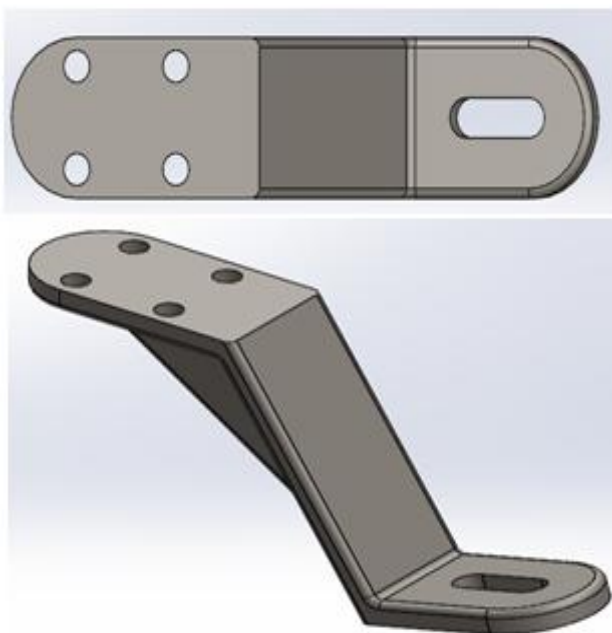

Fig-4: Final component

3. DESIGN CONSIDERATION FOR JIG

Points which are taken into consideration for designing a tool are as following:

4. MODIFIED ANGLE JIG

Variation in the angle-plate jig is called as modified angle-plate jig, which is used for machining angles other than 90 degrees.

4.1 Elements of Jig Tool

The body, Clamping devices, Locating devices, & bushes are the major elements of jigs.







4.1.1 The body -

As the most outstanding element of jigs and fixtures, the body is constructed by welding of different slabs and metals usually mild steel or by casting of cast iron. After the fabrication, it is often heat-treated for stress reduction as its main objective is to accommodate and support the job. The different types of jig bodies are:

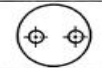
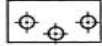
For Technical Institute of Technology
Dr. Pankaj Kumar Purohit
(Principal)

- ✓ Cast bodies.
- ✓ Welded bodies.
- ✓ Buildup bodies

Table 3 Jig Selection

Workpiece/Operation	Diagram	Selection of Jigs
Hole on the cylindrical workpiece		Template Jigs (Circular)
Hole on the rectangular surface		Template Jigs (Rectangular)
Irregular nonsymmetrical workpiece		Table Jigs
Flange with 4 or more holes		Box Jigs
To make a hole at an angle		Angle plate Jigs
To make hole at an angle		Angle plate Jigs
Hole on onside of the flange end		Pot Jigs
For unsuitable shape of component		Turn over Jigs Latch Jigs

4.1.2 Clamping Devices-

Before machining workpiece have to hold on machine tool, the holding operation done by clamping device. The clamping devices must be very simple & easy to operate. It should restrict all degree of freedom.

- ✓ Clamp position should not interfere with operation.
- ✓ For avoid deflection clamp should be provided on rigid surface of workpiece.

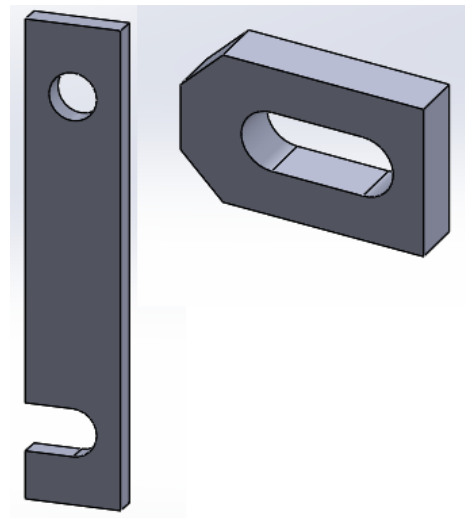

Fig-6: Clamps

4.1.3 Locating Devices-

To obtain desired accuracy of the finished product the proper location of work piece respect tool is important. Made with hardened steel and with different designs, the pin is the most popular device applied for the location of work-piece in jigs and fixtures.

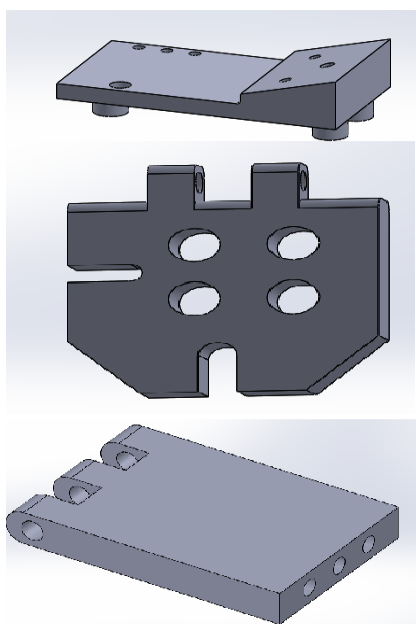

Fig-5: plates used for body of Jig

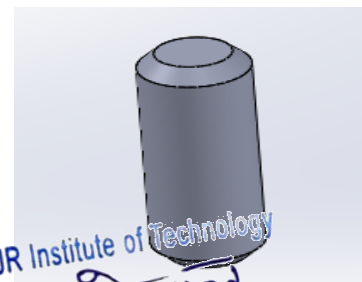

Fig-7: Locating pin

For Techno India NJR Institute of Technology
 पंकज कुमार
 Dr. Pankaj Kumar (Principal)

4.1.4 Jig Bushing-

Drill have tendency to wobble before starts drilling as a result holeproduce are not straight, exact potision and as per size. To overcome this problem we used bush.it helps to guide position and support cutting tool.

The jig bushings are categorized into three:

- ✓ the linear wearing bushes,
- ✓ press-fit wearing bushes,
- ✓ Renewable wearing bushes.

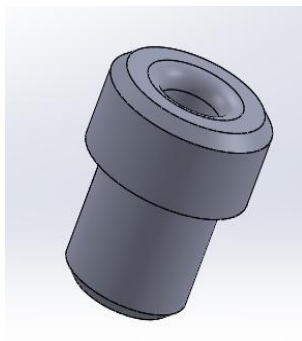

Fig-8: guiding bush

4.1.5 Fastening Devices-

These devices used to fix different parts of jigs on desire positions.the fastening devices are generally standard and available in market. Some times it is design as per requirement.

5. JIG ASSEMBLY

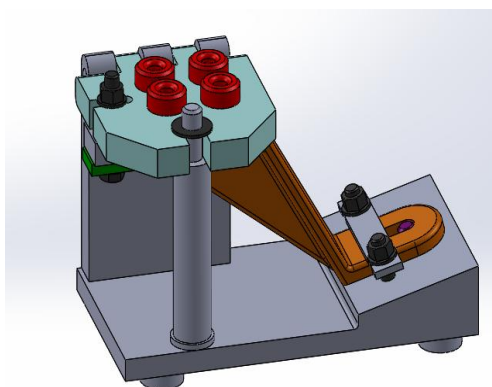

Fig-9: Assembly view

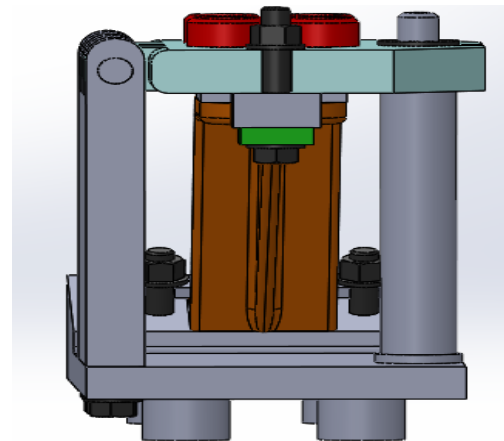

Fig-10: Assembly view

6. BILL OF MATERIAL

SR NO	DESCRIPTION	FINISH SIZE	QTY	MTR.
01	TOP PLATE (HINGED PLATE)	137x120x20 mm	1	M.S
02	BOTTOM PLATE (BASE PLATE)	250x130x47.78mm	1	M.S
03	SUPPORT PLATE (SIDE PLATE)	152x100x20 mm	1	M.S
04	COLUMN	Ø30x187 mm	1	MS
05	DOWELL	Ø12.5 x30 mm	1	M.S
06	LATCH CLAMP	20x100x5 mm	1	M.S
07	HINGE ROD	Ø12x100 mm	1	M.S
08	BOLT EXTENDED	M10x57 mm	2	M.S
09	BOLT EXTENDED	M10x72 mm	4	M.S
10	CLAMP	40x25 mm	1	M.S
11	DRILL BUSH	Ø30X48	1	M.S
12	REST BLOCK	30x22 mm	1	M.S
13	REST PAD	60x50x6 mm	1	M.S
14	NUT	M10	3	M.S
15	BUSH	Ø10mm	4	BRASS
16	NUT	Ø14 mm	1	M.S
17	WASHER	Ø14 mm	1	M.S

For Techno India NJR Institute of Technology
 पंकज पौरवाल
 Dr. Pankaj Kumar Porwal
 (Principal)

7. PROCESS OF LOADING & UNLOADING JIG

Step 1: The below is jig in open condition, put the workpiece into jig, locating pin will prevent workpiece placing wrong positioning.

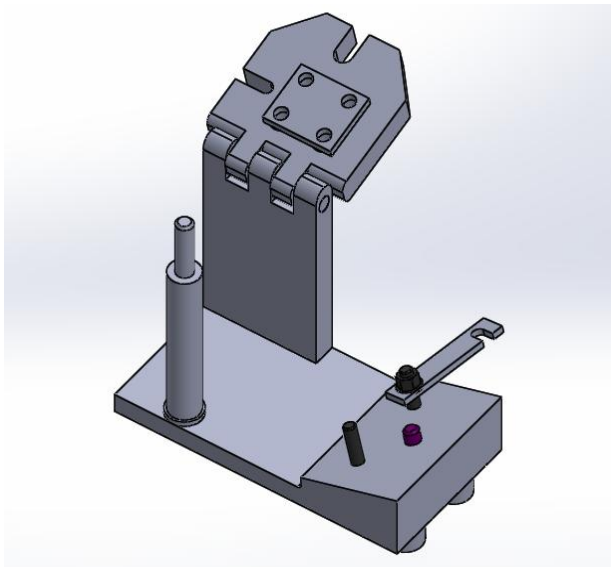

Fig-11: jig in open condition

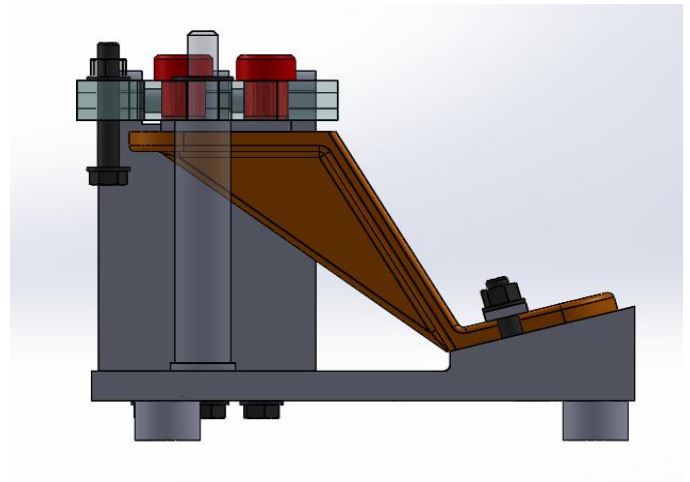

Fig-13: clamp on hinged plate

Step 4: Put the assembly of nut, clamp, rest block, washer & screw on hinged plate, adjust the rest block and then tight the screw.

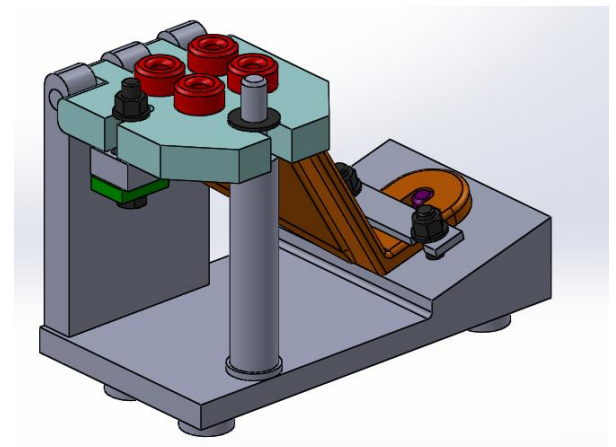

Fig-14: ready condition jig

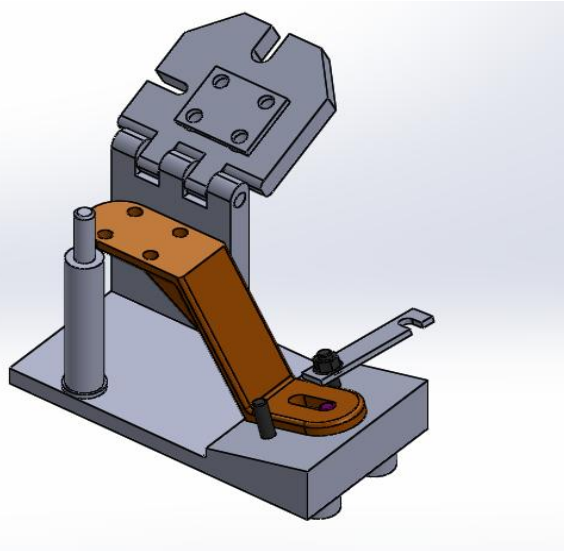

Fig-12: jig after workpiece placed

Step 2: After placing workpiece close the latch clamp. Revolve & tight screw for holding workpiece rigid.

Step 3: Close the hinged plate then revolve & tight screw on pillar.

Step 5: Workpiece is ready on jig for performing drilling operation.

Step 6: Follow the reverse procedure by loosening screws for unloading the workpiece from jig

For Techno India NJR Institute of Technology
 पंकज पोखराल
 Dr. Pankaj Kumar Porwal
 (Principal)

8. CONCLUSION

Thus the modified angle plate jig has been successfully designed and developed as per the requirements of component.

The usage of this jig will certainly help the industry in reducing the production time & also reducing the production cost apart from increasing the productivity. The cost incurred in the manufacturing of this jig can be obtained in the passage of time without affecting the profit of the company.

REFERENCES

Text Books:

- [1] P H Joshi, "Jigs and fixtures" Tata McGraw-Hill Education, 2010
- [2] Edward Hoffman "Technology & Engineering" Cengage Learning, 21-Aug-2003
- [3] Cyril Donaldson, V. C. Goold Machine-tools -Tata McGraw-Hill Education, 1976
- [4] Rajput, R.K. (2010), "Strength of Materials" Revised Edition, S. Chand and Company Limited.
- [5] Rajput, R.K, (2007), "A Textbook of Manufacturing Technology" Laxmi Publications, 1st Edition.
- [6] Khurmi, R.S. and Gupta, J.K. (2005), "A Textbook of Machine Design", Eurasia Publishing House.

For Techno India NJR Institute of Technology
पंकज पौरवाल
Dr. Pankaj Kumar Porwal
(Principal)