

Techno India NJR Institute of Technology



Course File Wind & Seismic Analysis (6CE3-01)

Bharat Suthar
(Assistant Professor)
Department of CE

For Techno India NJR Institute of Technology
पंकज पोखवाल
Dr. Pankaj Kumar Porwal
(Principal)



RAJASTHAN TECHNICAL UNIVERSITY, KOTA

Syllabus

3rd Year - VI Semester: B.Tech. (Civil Engineering)

6CE3-01: WIND AND SEISMIC ANALYSIS

Credit: 2
2L+0T+0P

Max. Marks: 100 (IA:20, ETE:80)
End Term Exam: 2 Hours

SN	CONTENTS	Hours
1	Introduction: Objective, scope and outcome of the course.	1
2	Structural Systems: Types of structures and Structure's forms, Symmetry and Asymmetry in building forms, Vertical and lateral loadresting elements, shear walls, framed tubes and various multistorey configurations.	4
3	Design Loads: various types of loads and relevant codes. Design loads for different types of buildings. (IS-875 part 1 & 2) & Load Flow Concept	3
4	Wind Loads Analysis: Wind loads & calculation of wind load on flat roof, pitched roof and single sloped roof buildings (IS: 875-Part 3).	8
5	Earthquake Load Analysis: Earthquake loads & calculations of earthquake loads on framed structures. (IS: 1893 – Part 1).	6
6	Earthquake Resistant Construction: Typical seismic failure of masonry and RCC structures. Earthquake resistant construction of buildings, and various provisions as per IS codes; IS-4326, IS-13827, IS-13828, IS-13920, IS-13935.	6
	TOTAL	28

Office of Dean Academic Affairs
Rajasthan Technical University, Kota

Syllabus of 3rd Year B. Tech. (CE) for students admitted in Session 2017-18 onwards.

For Techno India NJR Institute of Technology
पंकज पोखवाल
Dr. Pankaj Kumar Porwal
(Principal)

Course Overview:

Student will learn basics of “**Wind and Seismic analysis**” from these 28 hours course. **Wind and Seismic analysis** provide a fundamental understanding of the behaviour of steel, concrete, and composite building structures. Students will able to relate the typical process of designing a building, from the first step of determining design loads, to the final step of evaluating its behaviour for unusual effects under wind and earthquake.

Wind and Seismic analysis play a significant role in ensuring that all Company’s projects are aligned with strategic vision and objectives, and meet operational. **WSA** is the main requirement for the job role in the companies. Students should learn and develop problem solving abilities using this course in order to get a good job in top civil engineering company.

Course Outcomes:

CO. NO.	Cognitive Level	Course Outcome
1	Comprehension	Understand the types of structures, symmetry and asymmetry in building forms, shear walls and multi-storey configurations.
2	Analysis	Analyse design loads for different types of buildings.
3	Synthesis	Calculate wind load on flat roof, pitched roof and single sloped roof buildings.
4	Synthesis	Calculate earthquake loads on framed structures and design of Earthquake Resistant Construction.
5	Analysis	Apply wind & seismic load for analysing the structure to evaluate the response of lateral load.

Prerequisites:

- Students will be able to attain knowledge of Earthquake Resistant Construction as per the codal provision of Indian Standards
- Students will be able to describe the theory of lateral load distribution concept and structural systems phenomena.
- Students will be able to explain the principle of building analysis and behaviour of structure during lateral loads.

For Techno India NJR Institute of Technology
पंकज पोखरण
Dr. Pankaj Kumar Porwal
(Principal)

- Students will be able to apply wind & seismic load for analysing the structure to evaluate the response of lateral load

Course Outcome Mapping with Program Outcome:

Course Outcome	PO1	PO2	PO3	PO4	PO5	PO6	PO7	PO8	PO9	PO10	PO11	PO12	PSO1	PSO2	PSO3
CO361.1	3	2	2	2	1	1	1	1	1	1	1	1	1	1	2
CO361.2	2	2	1	1	1	2	1	1	2	2	2	1	1	2	2
CO361.3	3	2	2	2	1	1	1	1	1	1	1	1	1	1	2
CO361.4	3	2	2	2	2	2	2	1	2	1	1	1	2	2	3
CO361.5	3	3	3	3	2	1	2	1	2	1	1	2	3	3	2
CO361 (AVG)	2.8	2.2	2	2	1.4	1.4	1.4	1	1.6	1.2	1.2	1.2	1.6	1.8	2.2

Lecture No.	Unit	Topic
1	1	Introduction Objective, scope and outcome of the course
2	2	Structural Systems:
3	2	Types of structures and Structure's forms,
4	2	Symmetry and Asymmetry in building forms
5	2	Vertical and lateral load resting elements
6	2	Shear walls, framed tubes and various multistorey configurations
7	3	Design Loads:
8	3	various types of loads and relevant codes
9	3	Design loads for different types of buildings
10	3	(IS-875 part 1 & 2) & Load Flow Concept
11	4	Wind Loads Analysis:
12	4	Wind loads & calculation of wind load on flat roof
13	4	Wind loads & calculation of wind load on flat roof
14	4	Wind loads & calculation of wind load on flat roof
15	4	Wind loads & calculation of wind load on pitched roof
16	4	Wind loads & calculation of wind load on pitched roof
17	4	Wind loads & calculation of wind load on pitched roof
18	4	Wind loads & calculation of wind load on pitched roof
19	4	Wind loads & calculation of wind load on single sloped roof buildings
20	4	Wind loads & calculation of wind load on single sloped roof buildings
21	5	Earthquake Load Analysis:
22	5	Earthquake loads & calculations of earthquake loads on framed structures. (IS: 1893 – Part 1)
23	5	Numerical Practice on calculations of earthquake loads
24	5	Numerical Practice on calculations of earthquake loads

For Techno India NJR Institute of Technology
 पंकज पोखवाल
 Dr. Pankaj Kumar Porwal
 (Principal)

20	5	Numerical Practice on calculations of earthquake loads
21	5	Numerical Practice on calculations of earthquake loads
22	5	Numerical Practice on calculations of earthquake loads
23	6	Earthquake Resistant Construction: Typical seismic failure of masonry and RCC structures
24	6	Earthquake resistant construction of buildings, and various provisions as per IS codes IS-4326, IS-13827, IS-13828, IS-13920, IS-13935
25	6	Numerical Problems on Earthquake resistant construction
26	6	Numerical Problems on Earthquake resistant construction
27	6	Numerical Problems on Earthquake resistant construction
28	6	Numerical Problems on Earthquake resistant construction

TEXT/REFERENCE BOOKS

1. Earthquake Resistant Building Construction by Neelam Sharma, S.K. Kataria & Sons.
2. Seismic Analysis of Structures by T.K.Datta, John Wiley & Sons (Asia) Pte Ltd.
3. Earthquake Resistant Design of Structures by Pankaj Agarwal Manish Shrikhande, Prentice-Hall of India (PHI).
4. I.S. 1893 - 2002, Criteria for Earthquake Resistance design of Structures

Course Level Problems (Test Items):

CO.NO.	Problem description
1	<p>A. Explain Center of mass and Center of rigidity with an example. How their position will affect design of building for earthquake resistance?</p> <p>B. Explain the followings.</p> <p>a) Horizontal and vertical irregularities.</p> <p>b) Static and Dynamic analysis of RC buildings.</p>
2	<p>A. What are building configurations? Explain various Irregularities in buildings with sketch.</p> <p>B. Explain in brief the types of damages observed in traditional built construction during the earthquake with their sketch.</p> <p>C. Discuss the importance of ductile detailing of RC structure. Show the ductile detailing of a typical joint of beam and column of RCC framed building</p>

For Techno India NJR Institute of Technology
 पंकज पोखरण
 Dr. Pankaj Kumar Porwal
 (Principal)

3	<p>A. What are the seismic strengthening arrangements for masonry buildings? Explain the horizontal reinforced band in masonry construction.</p> <p>B. Design philosophies & assumptions for earthquake resistant RC buildings as per IS 1893 (Part-1) 2002.</p>
4	<p>A. Describe the shear wall. What are the functions of shear wall in RC framed building?</p> <p>B. Explain the general principles as per IS 4326:1993 for traditional built.</p>
5	<p>A. Determine the design base shear for plane frame and plan of five storied, symmetric RC building as shown in Fig. Building is special RC moment resisting frame with brick infill walls of 250mm thick longitudinal and 150mm thick transverse wall. Take floor height=3m, Size of beams 250 × 400 mm, columns 250 × 450 mm, slab 100mm thick, unit weight of RCC= 25 kN/m³, unit weight of brick = 20 kN/m³, type of soil is rocky. Live load is 3.5 kN/m².</p>

Assessment Methodology:

1. Assignments one from each unit.
2. Online Quiz at Google classroom.
3. Midterm subjective paper based on topics as mentioned in the modules (Twice during the semester).
4. Final paper at the end of the semester subjective.

TEACHING AND LEARNING RESOURCES UNIT-WISE

1) STRUCTURAL SYSTEMS:

Video Tutorials:

<https://www.youtube.com/watch?v=78UMDvdtL5Y&list=PLozwvoadUfmrvXImKgDCSliwQn3EAvwNC>

https://www.youtube.com/watch?v=2Oo_jsxgeIU&list=PLozwvoadUfmrvXImKgDCSliwQn3EAvwNC&index=2

<https://www.youtube.com/watch?v=BubfJUyfl9s&list=PLozwvoadUfmrvXImKgDCSliwQn3EAvwNC&index=3>

Theory concepts:

For Techno India NJR Institute of Technology
 पंकज पोखराल
 Dr. Pankaj Kumar Porwal
 (Principal)

<https://drive.google.com/drive/folders/1tpYcq-qGEAyjflahbVWyqaV10g9mRSn>

https://www.iitk.ac.in/nicee/IITK-GSDMA/EBB_001_30May2013.pdf

<https://drive.google.com/file/d/17kRMkBpotcrWjKYRuUXQGd0kssHvPad8/view>

Sample Quiz:

<https://www.uh.edu/~jbutler/physical/chap18mult.html>

2) WIND LOADS ANALYSIS

Video Tutorials:

<https://www.youtube.com/watch?v=w8nWHy54mKs&list=PLozwvoadUfmrVXImKgDCSliwQn3EAwvNC&index=8>

<https://www.youtube.com/watch?v=Qx5sJispJNc&list=PLozwvoadUfmrVXImKgDCSliwQn3EAwvNC&index=9>

<https://www.youtube.com/watch?v=WLLib6uyzYY&list=PLozwvoadUfmrVXImKgDCSliwQn3EAwvNC&index=10>

<https://nptel.ac.in/courses/105/108/105108204/>

<https://nptel.ac.in/courses/105/102/105102016/>

Theory concepts:

<https://drive.google.com/drive/folders/1tpYcq-qGEAyjflahbVWyqaV10g9mRSn>

https://www.iitk.ac.in/nicee/IITK-GSDMA/EBB_001_30May2013.pdf

<https://drive.google.com/file/d/17kRMkBpotcrWjKYRuUXQGd0kssHvPad8/view>

Sample Quiz:

<https://www.uh.edu/~jbutler/physical/chap18mult.html>

3) EARTHQUAKE LOAD ANALYSIS AND EARTHQUAKE RESISTANT CONSTRUCTION:

Video Tutorials:

<https://www.youtube.com/watch?v=p-tfixit380&list=PLozwvoadUfmrVXImKgDCSliwQn3EAwvNC&index=14>

For Techno India NJR Institute of Technology
पंकज पोखराल
Dr. Pankaj Kumar Porwal
(Principal)

<https://www.youtube.com/watch?v=Vp6K4MYmRHQ&list=PLozwvoadUfmrVXImKgDCSliwQn3EAvwNC&index=15>

<https://www.youtube.com/watch?v=vvkOSv4ASjg&list=PLozwvoadUfmrVXImKgDCSliwQn3EAvwNC&index=16>

Theory concepts:

<https://drive.google.com/drive/folders/1tpYcq-qGEAyjflahbVWyqaV10g9mRSn>

https://www.iitk.ac.in/nicee/IITK-GSDMA/EBB_001_30May2013.pdf

<https://drive.google.com/file/d/17kRMkBpotcrWjKYRuUXQGd0kssHvPad8/view>

Sample Quiz:

<https://www.uh.edu/~jbutler/physical/chap18mult.html>

For Techno India NJR Institute of Technology
पंकज पोखवाल
Dr. Pankaj Kumar Porwal
(Principal)

PREVIOUS YEAR QUESTION PAPERS

TECHNO INDIA NJR INSTITUTE OF TECHNOLOGY VI Sem, III Year, Civil Department Wind & Seismic Analysis (6CE1-03)

EXAM PAPER -1

1. Calculate wind load on rectangular clad building with mono-slope roof, Building is proposed to construct in Delhi. Consider height (h) = 4.5m, width (w) = 10m, length (l) = 18m, roof angle (α) = 20°, terrain category = 2, ground is flat and life of building is 25 years. Also, one of long side wall of building is open.

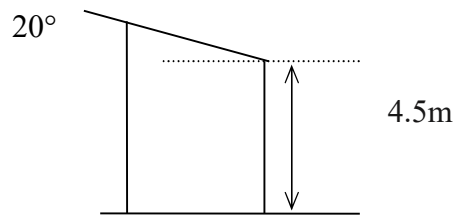

2. Calculate wind pressure and design forces on walls and roof of rectangular clad building with pitched roof, having plan dimensions 10m × 30m and height 5m. as shown in Fig.1. Building is situated in Jaipur on a hilltop 10m high having upwind and downwind slope of 15° and 1°, respectively as shown in Fig. The building has 16 opening of 1.5m × 1.5 m size and roof angle (α) = 15°. The columns and trusses are at 5m c/c longitudinally spaced and spacing of purlins is 1.4m c/c.

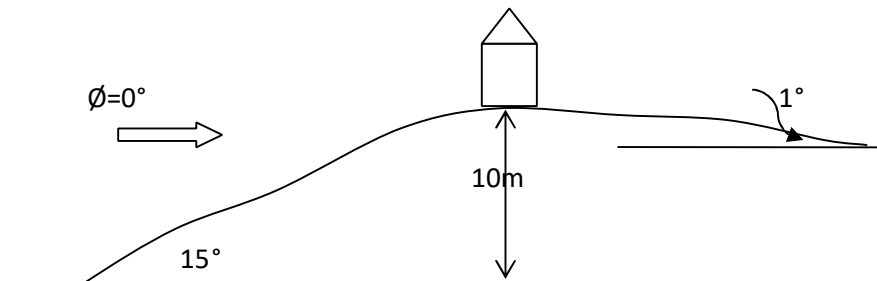

For Techno India NJR Institute of Technology
पंकज पोखवाल
Dr. Pankaj Kumar Porwal
(Principal)

3. Discuss the external pressure coefficient and internal pressure coefficient for pitched roof clad rectangular buildings.
4. Explain Center of mass and Center of rigidity with an example. How their position will affect design of building for earthquake resistance?
5. Explain the followings.
 - a) Horizontal and vertical irregularities.
 - b) Static and Dynamic analysis of RC buildings.
6. Determine the design base shear for plane frame and plan of five storied, symmetric RC building as shown in Fig. Building is special RC moment resisting frame with brick infill walls of 250mm thick longitudinal and 150mm thick transverse wall. Take floor height=3m, Size of beams 250×400 mm, columns 250×450 mm, slab 100mm thick, unit weight of RCC= 25 kN/m^3 , unit weight of brick = 20 kN/m^3 , type of soil is rocky. Live load is 3.5 kN/m^2 .

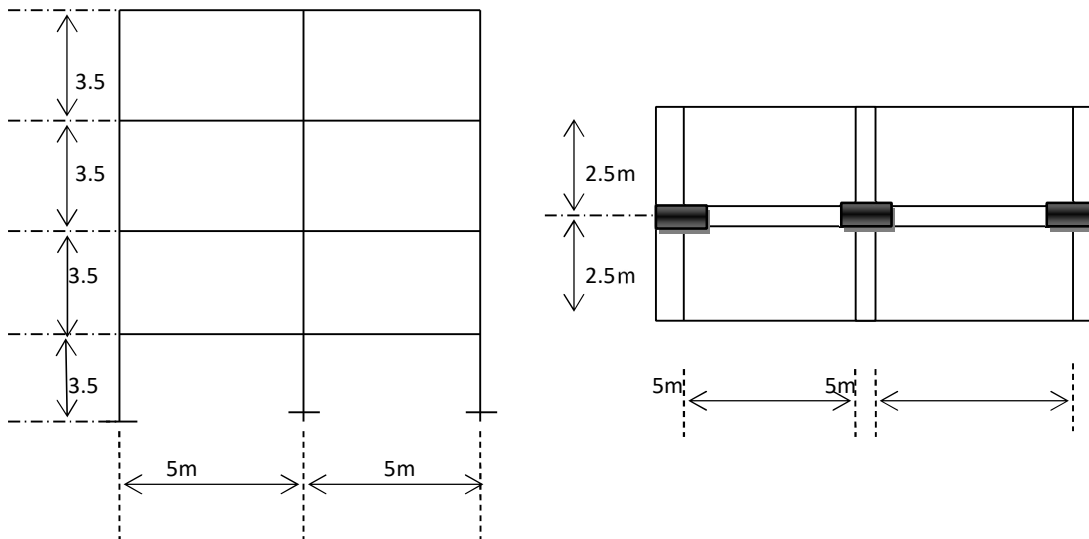

TECHNO INDIA NJR INSTITUTE OF TECHNOLOGY
VI SEM/VI Semester, Civil Department
Wind & Seismic Analysis (6CE1-03)

EXAM PAPER -2

- 1) What are building configurations? Explain various Irregularities in buildings with sketch.
- 2) Describe the shear wall. What are the functions of shear wall in RC framed building?
- 3) What is the Aspect ratio of building? Also discuss the advantages of its.
- 4) a) Explain in brief the types of damages observed in traditional built construction during the earthquake with their sketch.
b) Explain the general principles as per IS 4326:1993 for traditional built.
- 5) Explain in brief the types of damages observed in traditional built construction during the earthquake with their sketch.
- 6) Discuss the importance of ductile detailing of RC structure. Show the ductile detailing of a typical joint of beam and column of RCC framed building
- 7) Differentiate between folded plate and cylindrical shell. Also discuss the advantages of cylindrical shell.
- 8) Write short notes on following.
 - a) North Light shell roof.
 - b) Grid and ribbed floors.

For Techno India NJR Institute of Technology
पंकज पोखरण
Dr. Pankaj Kumar Porwal
(Principal)