

# **Techno India NJR Institute of Technology**



**B.Tech. IV Semester**

**Course File**

**ADVANCED SURVEYING LAB (4CE4-24)**

**Session 2022-23**

**Jitendra Choubisa**

**(Assistant Professor)**

**Department of CE**



**RAJASTHAN TECHNICAL  
UNIVERSITY, KOTA  
SYLLABUS**

**II Year-IV Semester: B.Tech. (Civil Engineering)**

**4CE4-24: ADVANCED SURVEYING LAB**

**Credit: 01  
(IA:30, ETE:20)**

**Max. Marks: 50  
0L+0T+2P**

1. To measure the horizontal and vertical angles by Theodolite.
2. To determine the Height of an object by trigonometric leveling (Instruments in same vertical plane).
3. To determine the Height of an object by trigonometric leveling (Instruments in different vertical planes).
4. Measurement of angles, length of survey line using Total Station, finding the coordinate of station
5. To measure and adjust the angles of a braced quadrilateral.
6. To prepare the map of given area by plane tabling.
7. Measurement of area of a traverse by Total Station

Office of Dean Academic Affairs  
Rajasthan Technical University, Kota

Syllabus of 2<sup>nd</sup> Year B. Tech. (AG) for students admitted in Session  
2017-18 onwards

---

**Course Overview :**

Advance surveying instruments provides faster and more precise surveying than conventional instruments. In conventional surveying, chain and tape are used for making linear measurements while compass and ordinary theodolites are used for making angular measurements. Levelling work is carried out using a Dumpy level and a levelling staff. With such surveying instruments, survey work will be slow and tedious. Hence modern surveying instruments are becoming more popular and they are gradually replacing old surveying instruments such as compass and Dumpy level. With modern surveying instruments, survey work will be precise, faster and less tedious.

**Course Outcomes:**

<b>CO.NO.</b>	<b>Cognitive Level</b>	<b>Course Outcome</b>
1	<b>Comprehension</b>	Test the relative altitudes and distance of different points onground.
2	<b>Application</b>	Perform the tests for setting of horizontal curves in field.
3	<b>Analysis</b>	Test the Survey work using Total-station.
4	<b>Synthesis</b>	Prepare the map of area by Plane Table.
5	<b>Evaluation</b>	Measurement of area of horizontal and vertical angle by TotalStation.

**Prerequisites:**

1. Fundamentals knowledge of Total Station Surveying.
2. Fundamentals knowledge of Plane Table Surveying.
3. Fundamentals knowledge of Theodolite Surveying .

### Course Outcome Mapping with Program Outcome:

Course Outcome	P O 1	P O 2	P O 3	P O 4	P O 5	P O 6	P O 7	P O 8	P O 9	PO 1 0	PO 1 1	PO 1 2	PS O 1	PS O 2	PS O 3
CO241 1.1	3	2	2	2	2	1	1	1	2	1	1	2	1	1	1
CO241 1.2	2	2	1	1	1	2	1	1	2	2	2	1	1	1	1
CO241 1.3	3	2	2	2	2	1	1	1	2	1	1	2	1	1	1
CO241 1.4	2	2	1	1	1	2	1	1	2	2	2	1	1	1	1
CO241 1.5	3	2	2	2	2	1	1	1	2	1	1	2	1	1	1
2411 (AVG)	2. 6	2	1. 6	1. 6	1. 6	1. 4	1	1	2	1. 4	1. 4	1. 6	1	1	1

### Course Coverage Module Wise:

Lab No.	Experiments List According to RTU Syllabus
1	To measure the horizontal and vertical angles by Theodolite.
2	To determine the Height of an object by trigonometric leveling (Instruments in same vertical plane).
3	To determine the Height of an object by trigonometric leveling (Instruments in different vertical planes).
4	Measurement of angles, length of survey line using Total Station, finding the coordinate of station
5	To measure and adjust the angles of a braced quadrilateral.
6	To prepare the map of given area by plane tabling.
7	Measurement of area of a traverse by Total Station

**Faculty Lab Manual Link**

[https://drive.google.com/file/d/1RSmacns7p0GGjN3pNXqLjmnSqA\\_EWYN2/view?usp=s\\_haring](https://drive.google.com/file/d/1RSmacns7p0GGjN3pNXqLjmnSqA_EWYN2/view?usp=s_haring)

**Viva QUIZ Link**

1. <https://www.indiabix.com/civil-engineering/advanced-surveying/>
2. <https://www.objectivebooks.com/2016/08/advanced-surveying-objective-questions-and-answers.html>
3. <https://www.objectivebooks.com/2016/11/mcq-on-advanced-surveying-set-02.html>

**Assessment Methodology:**

1. Practical exam using Advance Surveying Lab software.
2. Internal exams and Viva Conduct.
3. Final Exam (practical paper) at the end of the semester.

# **LAB MANUAL**

**B. Tech II Year**

**DEPARTMENT OF  
CIVIL ENGINEERING**

PRINCIPLES OF  
SURVEYING

## **PRINCIPLES OF SURVEYING**

The fundamental principles upon which the surveying is being carried out are

- Working from whole to part.
- After deciding the position of any point, its reference must be kept from atleast two permanent objects or stations whose position have already been well defined.

The purpose of working from whole to part is

- To localize the errors and
- To control the accumulation of errors.

This is being achieved by establishing a hierarchy of networks of control points (Stations having known position). The less precise networks are established within the higher precise network and thus restrict the errors. To minimise the errorlimit, highest precise network (primary network) Fig.1 of control points are established using the most accurate / precise instruments for collection of data and rigorous methods of analysis are employed to find network parameters. This also involves most skilled manpower and costly resources which are rare and cost intensive.



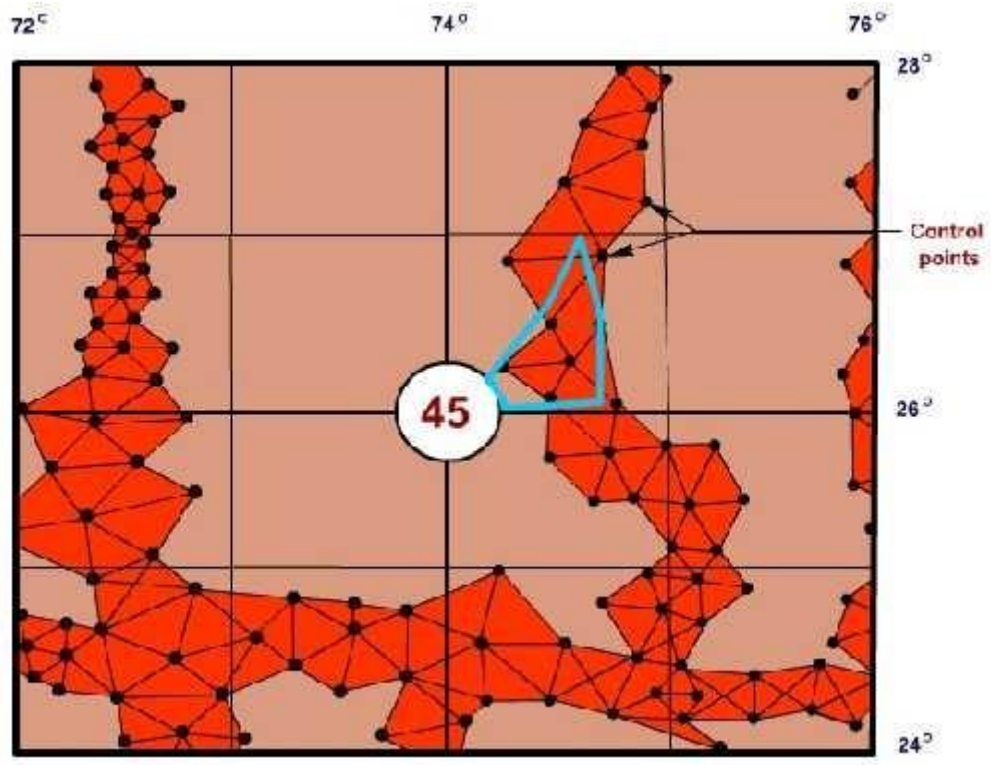


Fig.1 Network of Control Points

# **THEODOLITE SURVEYING**

## **THEODOLITE SURVEYING**

### **INTRODUCTION**

The Theodolite is one of the most precise surveying instruments and is suitable for measurement of horizontal as well as vertical angles. It has a powerful telescope and so it can be used also for distance sighting. Theodolites are of two types.

They are

Transit type

Non-Transit type

A transit Theodolite is one in which the line of sight can be reversed by reversing the telescope through  $180^{\circ}$  in the vertical plane. The non-transit Theodolites are either plain Theodolites or Y-Theodolites in which the telescope can not be transited. Now day's only transit Theodolites are being used.

### **PARTS OF TRANSIT THEODOLITE TRIVET**

It is a plate having a central circular threaded hole for fixing hole for fixing the Theodolite on tripod stand by a wing nut. It is also called the base plate or lower tribrach.

### **FOOT SCREW**

These are meant for leveling the instrument. There are three foot screws arranged in between trivet and tribrach.

### **TRI BRACH**

It is a triangular plate carrying the three-foot screws at its ends.

### **LEVELLING HEAD**

Trivet, foot screws and tribrach together form leveling head. Levelling the instruments, fixing the tripod, supporting the main instrument assembly are its uses.

## SPINDELS (OR) AXES

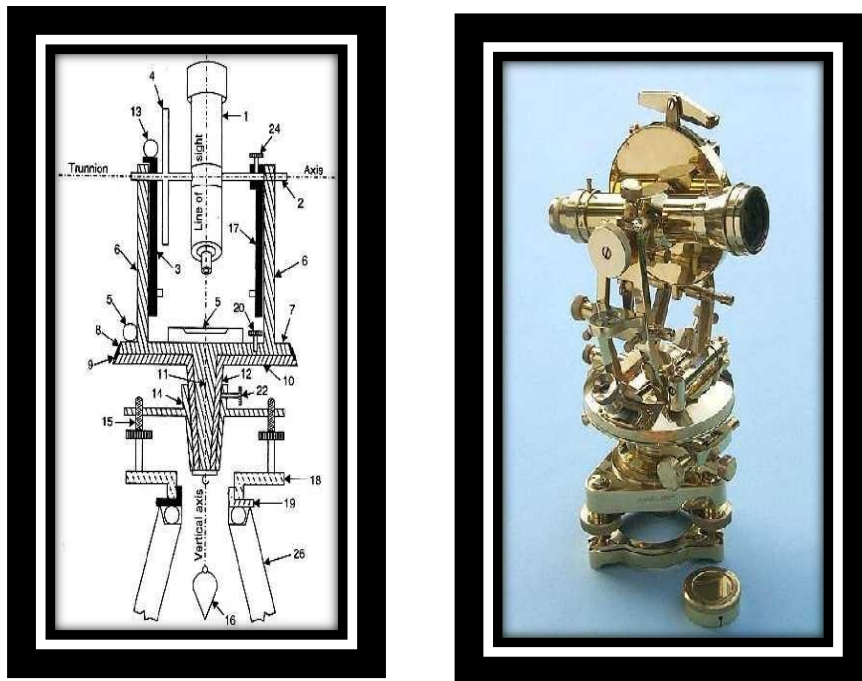
Two spindles one inner and other outer. Inner one is solid and rigid and outer one is hollow. To outer spindle lower plate is attached. To inner spindle upper plate is attached.

## LOWER PLATE

Graduated from  $0^0$  to  $360^0$  in clockwise direction provided with a lower clamping and tangent screw.

## UPPER PLATE

Contains vernier 'A' and 'B' provided with upper clamping and upper tangent screw.



**Fig.2 Theodolite and its Parts**

1. Telescope
2. Levelling Head

3. Trunnion Axis
4. Levelling Screw
5. Vernier Frame
6. Plumb Bob
7. Vertical Circle
8. Arm Of Vertical Circle Clamp
9. Plate Levels
10. Foot Plate
11. Standards (A-Frame)
12. Tripod Head
13. Upper Plate
14. Upper Clamp
15. Horizontal Plate Vernier
16. Lower Clamp
17. Horizontal Circle
18. Vertical Circle Clamp
19. Lower Plate
20. Tripod
21. Inner Axis
22. Outer Axis
23. Altitude Level

### **PLATE BUBBLE**

It is meant for leveling the instrument at the time of measuring horizontal angles.

### **STANDARD (OR) A – FRAME**

Two frames are provided on upper plate to support the telescope assembly.

### **TELESCOPE**

Fitted in between standards. Perpendicular to the horizontal axes provided with afocusing screw, clamping screw and tangent screw.

### **VERTICAL CIRCLE**

Fixed rigidly with the telescope and moves with it. Each quadrant is graduated from  $0^0$  to  $90^0$ . Zero is marked at the ends of horizontal diameter.

### **INDEX BAR (OR) T-FRAME**

Provided on the stand in front of the vertical circle. It carries the vernier 'C' and 'D'. These verniers are used for taking the readings of the vertical circle. The vertical log of Index bar is provided with a clip screw. At the lower end by means of which the altitude bubbles can be brought to the center.

### **ALTITUDE BUBBLE**

Provided on top of index bar. It is to be leveled while taking vertical angle readings.

### **TRIPOD**

The tripod head carries at its upper surface an external screw to which trivet plate of base plate of the leveling head may be screwed.

### **PLUMB BOB**

It is used for centering the Theodolite.

### **COMPASS**

Some Theodolites are provided with a compass, which can be either tubular type (or) trough type.

### **TERMS USED CENTERING**

Keeping the instrument exactly above the station mark, by means of a plumb bob is known as centering.

### **TRANSITING**

Turning the telescope about the horizontal axis in the vertical plane through  $180^0$  is called transiting.

### **FACE LEFT**

If the vertical circle of the Theodolite is on the left of observer at the time of taking readings. It is known as face left and also called as telescope normal (or) bubble up.

## **FACE RIGHT**

If the vertical circle of the Theodolite is on the right of observer at the time of taking readings it is known as face right. It is also called as telescope inverted (or) bubble down.

## **CHANGING FACE**

Operation of bringing the vertical circle from one side of the observer to the other side is known as changing face. It is done by transiting the telescope and turning it through  $180^{\circ}$  in the horizontal plane.

## **SWINGING THE TELESCOPE**

It is the process of turning the telescope in horizontal plane. If the telescope is rotated in clockwise direction. It is known as right swing. If the telescope is rotated in anticlockwise direction. It is known as left swing.

## **LINE OF COLLIMATION**

It is the line joining the intersection of cross hairs and optical center of the object glass and its continuation.

## **AXIS OF TELESCOPE**

Imaginary line passing through the optical center of the object glass and the optical center of the eyepiece.

## **AXIS OF BUBBLE TUBE**

It is an imaginary line tangential to the longitudinal curve of the bubble tube at its middle.

## **HORIZONTAL AXIS**

It is the axis about which the Theodolite or the telescope rotates in the horizontal plane.

## **VERTICAL AXIS**

It is the axis about which the Theodolite or the telescope rotates in the vertical plane.

## **TEMPORARY ADJUSTMENTS**

The temporary adjustments are to be done at every set up of the instrument. These mainly involves –

Centering

Leveling

Focusing

### **CENTERING THE THEODOLITE OVER THE STATION**

Place the tripod over the station and fix the Theodolite using wing out.

Approximate centering and leveling is done by tripod stand

Accurate centering is done with the help of shifting head.

### **LEVELLING**

Approximate leveling is made with the help of tripod legs

Accurate leveling is made with the help of foot screws.

### **FOCUSSING THE EYE PIECE**

A piece of white paper is held in front of the object glass and eye piece is moved in (or) out by turning it clockwise (or) anti clockwise until cross wires appear distinct and sharp.

### **THE OBJECT GLASS**

The telescope is directed towards the objects and focusing screw is turned clockwise (or) anticlockwise until the image appears clean and sharp.

### **SETTING THE VERNIER**

The vernier 'A' is set to zero. Lower clamping screw is fixed and upper clamping is rotated till the Index of vernier shows zero. Upper tangent screw is used for setting the vernier exactly to zero.

### **PRECAUTIONS**

- Leveling and centering must be done perfectly.
- Relation of fundamental lines at Theodolite must be maintained while taking readings.
- Ranging rod should not be disturbed for taking preceding angles.
- Care should be exercised in taking out the Theodolite from the box and in screwing it to the tripod. A Theodolite fitted on a tripod should never be set upon the floor as it may lead to serious damage. While placing the Theodolite into the box, the leveling



head should be shifted to a central position and the foot screws should be evened all around. The clamp should be released during transit so that the different parts can yield without being damaged, in case it strikes some obstruction.

- Clamps and screws should especially be carefully operated. Unnecessary pressure should not be used in tightening them. If the screws do not turn easily, they should be cleaned with a good solvent such as alcohol or gasoline.
- The wing nuts on the tripod must be tight so as to prevent slippage and rotation of the head. The tripod legs should be well spread out to furnish stability to the instrument and to permit placement of the telescope at a convenient height for the observer.
- The vertical circle should be cleaned if tarnished in use. However, excessive rubbing should be avoided, otherwise the engraved graduations will get impaired.
- The Theodolite should be protected from moisture and dust as far as possible. If it has been exposed to moisture it should be wiped dry before replacing it in the box.

### **APPLICATIONS**

Laying off horizontal angles, locating points on line, prolonging survey lines, establishing grades, determining difference in elevation, setting out curves etc.



## MEASUREMENT OF HORIZONTAL ANGLE

**Aim** To determine the horizontal angle by using transit Theodolite

**Equipment:**

Theodolite, Tripod Stand, Ranging Rods, Plumb Bob and Pegs.

**Principle:**

The Theodolite is most accurate instrument used for measurement of horizontal and vertical angles. To measure the horizontal angle, the angles obtained are added and is divided with number of angles. Firstly for taking every angle vernier 'A' is made to zero, if it is provided with 'B' also make it to zero, otherwise its vernier reading is noted down. The angles are measured by keeping the telescope in normal and inverted positions. Then the readings are taken by swinging the telescope to the right and left, which is called as right swing and left swing.

The average included angle is obtained as

$$\text{Average included Angle} = \frac{\text{Sum of included angles of both faces}}{\text{No. of times}}$$

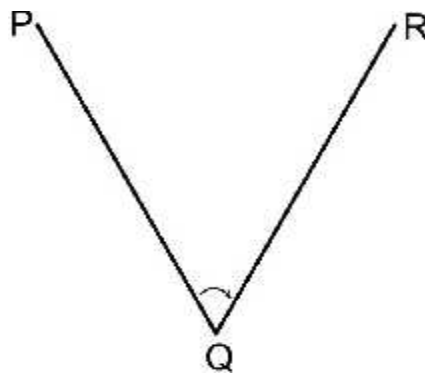
**Procedure:**

To measure horizontal angles say angle PQR (Fig.3), the following procedure is followed.

1. Set-up the instrument at Q and level it.
2. Loose the upper clamp and turn the upper plate until the index arrow of the vernier 'A' nearly coincides with the horizontal circle. Now tight the upper clamp.
3. Turn the upper slow motion (tangent) screw so as to make the two zeros exactly coincide, so that 'A' vernier reads zero and 'B' vernier reads  $180^{\circ}$ .
4. Loose the lower clamp and direct the telescope to sight station P. The approximate bisection of the station is done by sighting from over the telescope through a pin and hole arrangement provided over its top. Now tighten the lower clamp.
5. Bisect station 'P' exactly by using the lower slow motion (tangent screw)
6. Unclamp the upper clamp and swing the telescope and bisect the station R.

Now tighten the upper clamp and bisect R accurately using the upper tangent screw.

7. Read the verniers, the reading of vernier 'A' gives the angle PQR directly while the vernier 'B' obtained by deducting  $180^0$ .
8. While entering the reading the full reading of vernier 'A', i.e., degree, minutes and seconds and only minutes and seconds of vernier 'B' are entered, the mean of the two readings gives the angle PQR.
9. Change the face of the instrument repeat the procedure, thus a second value of the angle PQR is obtained. The average of these two values is the requirement i.e. to say required angle.



**Fig.3 Measurement of Horizontal Angle**

**Observations and Calculations:**

$\sphericalangle PQR =$

**Result:**

The required average included angle PQR that is horizontal is determined by using transit theodolite as  $\sphericalangle PQR =$

**Comments/Inference:**

Write your comments and observations on the result obtained.

## MEASUREMENT OF VERTICAL ANGLE

### **Aim:**

To measure the vertical angle subtended by the line of sight of a given rod with reference to the horizontal axis at a selected station.

### **Equipment:**

Transit Theodolite, Tripod Stand, Plumb Bob, Ranging Rod and Pegs.

### **Principle:**

The vertical angle is the angle made by an inclined line of sight with horizontal line of sight. Vertical angles are measured by using telescope clamping and telescope tangent screws.

### **Procedure:**

**Let  $\angle AOB$  is to be measured (Fig.4):**

Setup the instrument doing the exact adjustments (centering, leveling and focusing the eyepiece)

The centering is done with reference to altitude bubble.

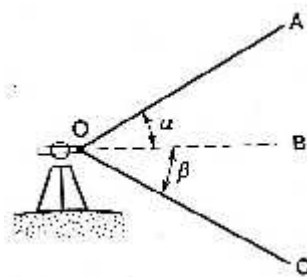
Keep the instrument in the left position make the vernier 'C' read zero with the help of vertical circle clamp & tangent screws.

Bring the altitude bubble to zero when the telescope is horizontal.

- i) Direct the telescope to the object and bisect it accurately by means of the vertical circle clamp and tangent screw.
- ii) Read both the vernier 'C' and 'D' and take the average, which gives the value of vertical angle.
- iii) Change the face and repeat the procedure.
- iv) The required vertical angle is the average of face left and face right.

**Let  $\angle AOC$  is to be measured (Fig.4):**

1. The instrument is already setup on the station at 'O'.
2. Direct the telescope to the top of the rod and bisect it accurately by means of the vertical.
3. Read the both verniers 'C' and 'D' and take the average which gives the value of vertical angle ' $\alpha$ '.
4. Then the telescope is bisected to the bottom of the rod. Then read the both verniers 'C' and 'D' readings the average gives the value of vertical angle ' $\beta$ '.
5. The summation of  $\alpha$  &  $\beta$  gives the  $\angle AOC$ .
6. The face is changed and same procedure should be repeated then find
7.  $\angle AOC$ .
8. The average of this two gives the  $\angle AOC$ .



**Fig.4 Measurement of Vertical Angle**

**Observations and Calculations:**

$\alpha =$      $\beta =$

Horizontal Distance,  $D = \text{Vertical Height} = D (\text{Tan}\alpha + \text{Tan}\beta)$

**Result:**

The vertical angle to the given ranging rod is measured as  $\angle AOC = \text{Height of the given object} =$

**Comments/Inference:**

Write your comments and observations on the result obtained.

## **MEASUREMENT OF HORIZONTAL ANGLE(BY REPETITION METHOD)**

### **Aim:**

To determine a horizontal angle by the method of repetition.

### **Equipment:**

Transit Theodolite, Tripod, Plumb Bob, Ranging Rods and Pegs.

### **Principle:**

In the method of repetition, the angle is measured and added to itself several times and divided by the number of times it is added. It is then possible to obtain the value of angle to a greater degree of accuracy than the least count of the vernier. The error due to imperfect graduations is also minimized.

### **Procedure:**

The method of repetition is used to measure a horizontal angle to a finer degree of accuracy than that obtainable with the least count of the vernier. By this method an angle is measured two (or) more times by allowing the vernier to remain clamped each time at the end of each measurement instead of setting it back at zero when sighting at the previous station. Thus an angle reading is mechanically added several times depending upon the number of repetitions. The average horizontal angle is then obtained by dividing the final reading by number of repetitions. Generally six repetitions are done three with the telescope normal and three with the telescope inverted.

1. To measure the horizontal angle, say angle PQR (Fig.5) the following procedure is followed.
2. Setup the instrument at 'Q' and level it.
3. Loosen the upper clamp and turn the upper plate until the index of vernier 'A' nearly coincide with the horizontal circle. Now tight the upper clamp.
4. Turn the upper tangent screw so as to make the two zeros exactly coincide. So that

- 'A' vernier reads  $0^0$  and 'B' vernier reads  $180^0$ .
5. Sight station 'P', tighten the lower clamp and bisect station 'P' exactly by using the lower tangent screw.
  6. Unclamp the upper clamp and swing the telescope, bisect station 'R' by using the upper clamp and upper tangent screw.
  7. Read both the verniers take average to get  $\angle PQR$ .
  8. Unclamp the lower clamp and swing the telescope and bisect station 'P' accurately by using the lower clamp and lower tangent screw.
  9. Read both the verniers check the vernier reading it should be the same (unchanged) as that obtained in step 6.
  10. Release the upper plate by using upper clamp and bisect station 'R' accurately by using upper tangent screw. The vernier will read twice the PQR
  11. Repeat the procedure for required number of times say three times and find out the value of  $\angle PQR$ .
  12. Change face and make three more repetitions as described above. Find the average angle with face right by dividing the final reading by three or whatever the number of repetitions.
  13. The average Horizontal angle is then obtained by taking the average of the two angles obtained with face left and face right.

**Result:**

The angle is measured by the method of repetition and the obtained Horizontal angle is

$\angle PQR =$

**Comments/Inference:**

Write your comments and observations on the result obtained.



# HEIGHTS AND DISTANCES (TRIGONOMETRIC LEVELLING)

## BASE ACCESSIBLE

**Aim:** To find the elevation of the top of a spire / tower / building using the principle of trigonometric leveling.

### Equipment:

Transit Vernier Theodolite, Tripod stand, Plumb bob, Tape, Leveling Staff and Pegs.

### Procedure:

It is required to find the elevation (R.L.) of the top of a tower 'Q' from the instrument station 'P' as shown in Fig.7.

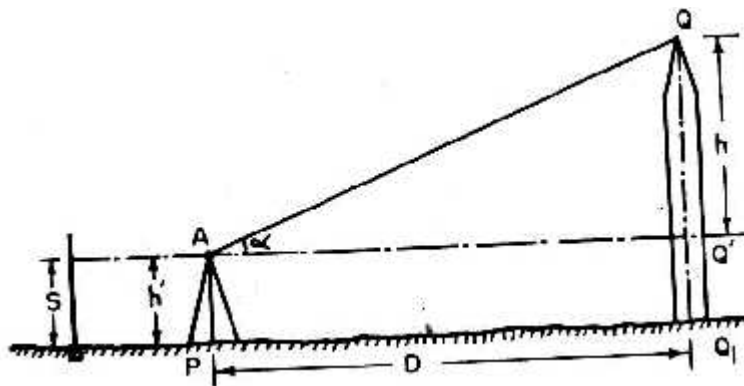


Fig.7 Base Accessible

Let,

P= instrument station Q= Point to be observed

A= center of the instrument

D= horizontal distance between P and Q  $h'$  = height of the instrument at P  $Q'$ =Projection of Q on horizontal plane

S= Reading on staff kept on B.M, with line of sight on horizontal

$\alpha$  = Angle of elevation from A to Q

1. Setup the Theodolite at P and level it accurately w.r.t. the altitude bubble. See that the vertical circle reads  $0^{\circ}0'0''$  when the line of sight is horizontal.
2. Direct the telescope towards Q and bisect it accurately clamp both the plates. Read the vertical angle ' $\alpha$ '.
3. Plunge the telescope and sight to the same point 'Q' and take the vertical angle ' $\alpha$ ' calculate the avg. of the vertical angles measured in both faces.
4. With the vertical vernier set to zero reading and the altitude bubble in the center of its run take the reading on the leveling staff kept at A.B.M. Let it be 'S'.

**Observations and Calculations:**

Vertical Angle,  $\alpha =$  Staff Reading, S (m) = Horizontal Distance, D (m) =

From Triangle AQQ':  $h = D \tan \alpha$

R.L. of Q (m) = R.L of B.M + S + h where  $h = D \tan \alpha$  (Or)

R.L. of Q (m) = R.L of instrument axis +  $D \tan \alpha$  (Or)

R.L. of Q (m) = R.L of P + h' +  $D \tan \alpha$ , if R.L of P is Known

**Result:**

R.L. of Q (m) = R.L of B.M + S + h where  $h = D \tan \alpha$

**Comments/Inference:**

Write your comments and observations on the result obtained.

## BASE INACCESSIBLE (SINGLE PLANE METHOD)

### Aim:

To find the elevation of the top of a building using the principle of trigonometrical leveling with the instrument stations having their vertical axes in the same plane as the object.

### Equipment:

Transit Vernier Theodolite, Tripod Stand, Plumb Bob, Tape, Leveling Staff and Pegs.

### Procedure:

It is required to find the elevation (R.L.) of the top of a building 'Q' from the instrument stations P & R as shown in Fig.8.

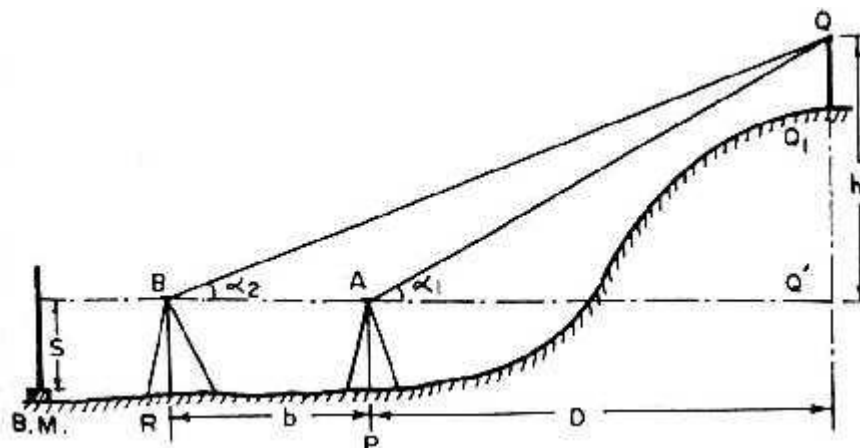


Fig.8 (a) Instrument Axis at Same Levels

$$h = QQ'$$

$$b = \text{Horizontal dist. b/w P \& R}$$

$$D = \text{Horizontal dist. b/w P \& Q}$$

$$\alpha_1 = \text{angle of elevation from A to Q}$$

$$\alpha_2 = \text{angle of elevation from B to Q}$$

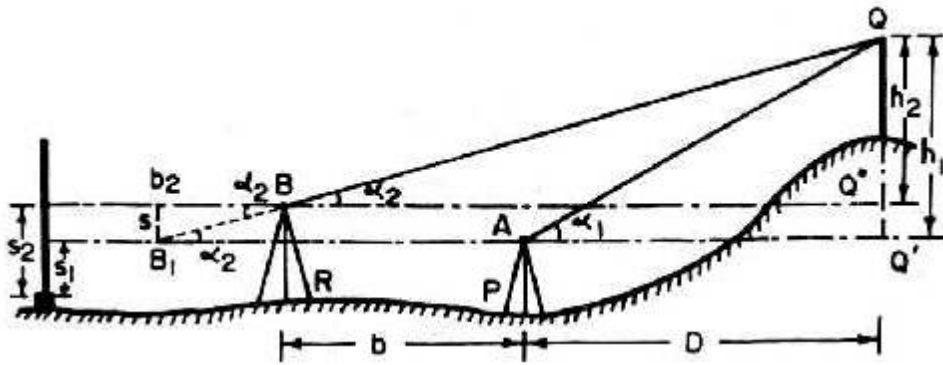


Fig.8 (b) Instrument Axes at Different Levels

1. Setup the Theodolite at P and level it accurately with respect to the altitude bubble. See that the vertical circle reads  $0^{\circ}0'0''$  when the line of sight is horizontal.
2. Direct the telescope towards Q and bisect it accurately clamp both the plates. Read the vertical angle  $\alpha_1$ .
3. Transit the telescope so that the line of sight is reversed. Mark the instrument station R on the ground along the line of sight. Measure the dist. b/w P & R accurately. Let it be 'b' repeat the steps (2) & (3) for both face observations. The mean values should be adopted in the calculations.
4. With the vertical vernier set to zero reading and the altitude bubble in the center of its run take the reading on the leveling staff kept at A.B.M. Let it be 'S' if both the instrument axis are at same level and 'S1' if they are at different levels.
5. Shift the instrument to R and set up the Theodolite there. Measure the vertical angle ' $\alpha_2$ ' to Q with both face observations.
6. In case of instrument axis at different levels repeat the step (4) and let the reading at R be 'S2'.

**Observations and Calculations:**

Vertical Angles,  $\alpha_1 =$  Staff Readings S1 (m) = (or) S (m) =

$\alpha_2 =$  S2 (m) =

Horizontal dist. b/w P & R = b =

**In case of instrument axis at same level:**

$$\text{From triangle } AQQ'h = D \tan \alpha_1$$

$$\text{From triangle } BQQ'h = (b + D) \tan \alpha_2$$

$$D = \frac{b \tan \alpha_2}{\tan \alpha_1 - \tan \alpha_2}$$

$$\tan \alpha_1 - \tan \alpha_2$$

$$\text{R.L. of Q (m)} = \text{R.L. of B.M.} + S + h$$

**In case of instrument axis at different levels:**

$$h_1 - h_2 = S_2 - S_1 = S$$

$$D = \frac{S + b \tan \alpha_2}{\tan \alpha_1 - \tan \alpha_2}$$

$$\tan \alpha_1 - \tan \alpha_2 h_1 = D \tan \alpha_1$$

$$h_2 = (b + D) \tan \alpha_2$$

$$\text{R.L. of Q} = \text{R.L. of B.M.} + S_1 + h_1$$

$$\text{R.L. of Q} = \text{R.L. of B.M.} + S_2 + h_2$$

**Result:**

$$\text{R.L. of given point Q (m)} =$$

**Comments/Inference:**

Write your comments and observations on the result obtained.

.

# SETTING OUT A SIMPLE CURVE BY TWO-THEODOLITE METHOD

**Aim:**

Two tangents intersect at a given chainage with a given deflection angle. Calculate all the necessary data for setting out a curve with a given radius by two Theodolite method. The peg interval is 30m.

**Equipment:**

Two Transit Theodolites, Tripod Stands, Ranging Rods and Pegs.

**Principle:**

In this method two Theodolites are used one at T1 (P.C) and the other at T2 (P.T). The method is used when the ground is unsuitable for chaining and is based on the principle that the angle between the tangent and the chord is equal to the angle which that chord subtends in the opposite segment.

Thus,

$$\angle VT_1 A = \angle 1$$

= deflection angle for 'A' but

$$\angle AT_2 T_1$$

is the angle subtended by

the chord T1 A in the opposite segment.  $\angle AT_2 T_1 = \angle VT_1 A = \angle 1$

Similarly

$$\angle VT_1 B = \angle 2 = \angle T_1 T_2 B$$

$$\angle VT_1 C = \angle 3 = \angle T_1 T_2 C$$

-----

-----  
□VT<sub>1</sub>T<sub>2</sub> □□<sub>n</sub> □□T<sub>1</sub>T<sub>2</sub>V

**Procedure:**

Set up one transit at P.C. (T<sub>1</sub>) and the other at P.T. (T<sub>2</sub>) (Fig.12).

Clamp the both plates of each transit to zero reading.

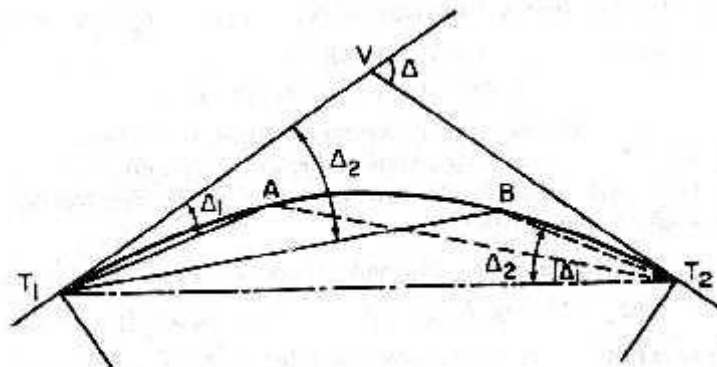
With the zero reading, direct the line of sight of the transit T<sub>1</sub> towards V. Similarly, direct the line of sight of the other transit at T<sub>2</sub> towards T<sub>1</sub> when the reading is zero. Both the transits are thus correctly oriented.

Set the reading of each of the transits to the deflection angle for the first point 'A'. The line of sight of both the Theodolites are thus directed towards 'A' along T<sub>1</sub>A and T<sub>2</sub>A respectively.

Move the ranging rod or arrow in such a way that it is bisected simultaneously by cross hairs of the both instruments. Thus point A is selected.

To fix the second point 'B'. Set reading □<sub>2</sub> on both instruments & bisect the ranging rod.

Repeat the steps (4) & (5) for calculation of all the points.



**Fig.12 Setting Out By Two-Theodolite Method**

**Result:**

The required simple circular curve is set out in the field by two-theodolite method.

**Comments/Inference:**

Write your comments and observations on the result obtained.

# TACHOMETRIC SURVEY



## TACHEOMETRIC SURVEY

### INTRODUCTION

Tacheometer in general sense, is a transit Theodolite fitted with anallactic lens (Fig.13) and a stadia diaphragm (Fig.14) consisting of one stadia hair above and the other at equal distance below the horizontal cross hair (Fig.15).

The stadia hairs are kept in the same vertical plane as the other cross hairs.



**Fig.13 Tacheometer**

## TYPES OF STADIA DIAPHRAGM

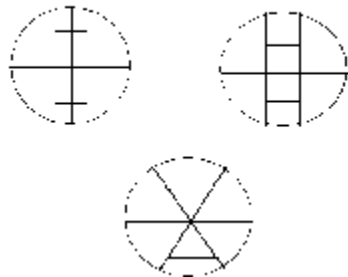


Fig.14 Stadia Diaphragms

## STADIA RODS

1. For the short distances ordinary leveling staffs may be used
2. For greater distance the stadia rods of 3 to 4 meters in length are generally used

## STADIA READINGS

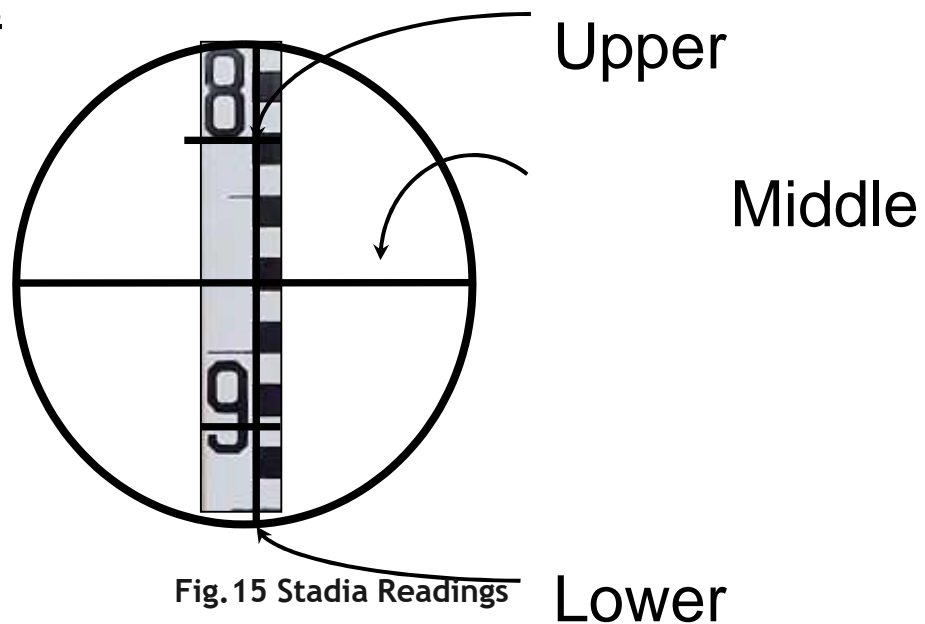


Fig.15 Stadia Readings

## TYPES OF TELESCOPES USED IN STADIA SURVEYING

- ❖ The simple external-focusing telescope.
- ❖ The external-focusing anallactic telescope.
- ❖ The internal telescope

## CHARACTERISTICS OF TACHEOMETER

- ❖ The value of the constant  $f/i$  should be 100.

- ❖ The telescope should be fitted with an anallactic lens.
- ❖ The axial horizontal line should be at center of the other two horizontal line
- ❖ The telescope should be powerful, the magnification being 20 to 30 diameter.
- ❖ The aperture of the objective should be 35 to 45mm in diameter.
- ❖ The magnifying power of the eyepiece should be greater to render staff graduations clearer at long distance.

### **PRECAUTIONS**

1. Leveling and centering must be done perfectly.
2. Relation of fundamental lines at Theodolite must be maintained while taking readings.
3. Ranging rod should not be disturbed for taking preceding angles.
4. Care should be exercised in taking out the Theodolite from the box and in screwing it to the tripod. A Theodolite fitted on a tripod should never be setup on the floor as it may lead to serious damage. While placing the Theodolite into the box, the leveling head should be shifted to a central position and the foot screws should be evened all around. The clamp should be released during transit so that the different parts can yield without being damaged, in case it strikes some obstruction.
5. Clamps and screws should especially be carefully operated. Unnecessary pressure should not be used in tightening them. If the screws do not turn easily, they should be cleaned with a good solvent such as alcohol or gasoline.
6. The wing nuts on the tripod must be tight so as to prevent slippage and rotation of the head. The tripod legs should be well spread out to furnish stability to the instrument and to permit placement of the telescope at a convenient height for the observer.
7. The vertical circle should be cleaned if tarnished in use. However, excessive rubbing should be avoided, otherwise the engraved graduations will get impaired.
8. The Theodolite should be protected from moisture and dust as far as possible. If it has been exposed to moisture it should be wiped dry before replacing it in the box.

### **APPLICATIONS**

- Tacheometer prime object is to prepare contour maps (or) plans requiring both the horizontal as well as vertical control.

# HEIGHTS AND DISTANCES USING PRINCIPLES OF TACHEOMETRIC SURVEYING

## TACHEOMETRIC CONSTANTS

**Aim:**

To determine the Tacheometric constants using Tacheometer.

**Equipment:**

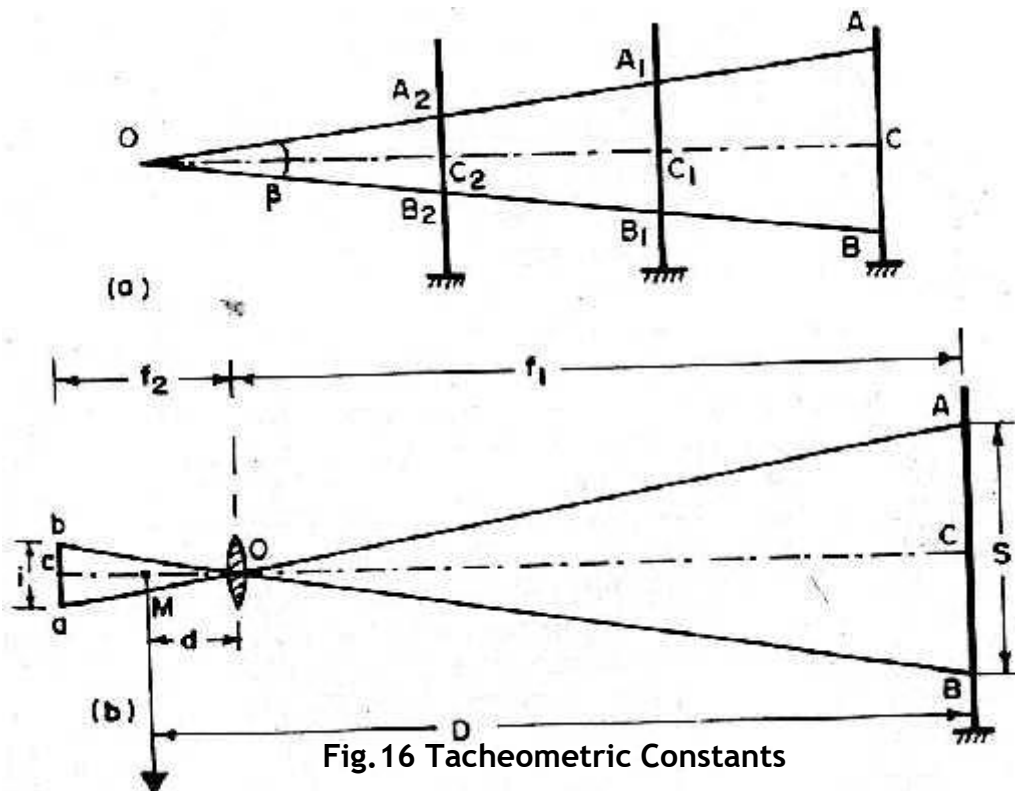
Tacheometer, Chain (or) Tape, Pegs and Levelling Staff.

**Principle:**

Distance between two points is given by (Fig.16)

$$D = \frac{f}{i} s \pm (f + d)$$

Where  $f/i$  is called the multiplying constant.  $(f + d)$  is called additive constant.



**Procedure:**

Setup the instrument at one end of a straight line say 50m

Drive pegs at 10m, 20m, 25m and at 50m lengths...

Keep the staff on the pegs and observe the corresponding staff intercepts with horizontal sight.

Knowing the values of 'S' and corresponding 'D' values for different peg intervals a number of similar equations can be formed by substituting the values of 'S' and 'D' in equation

$$D = KS + C$$

The simultaneous equations are taken two at a time to find the values of 'K' and 'C'.

The average values of 'K' and 'C' are found.

**Observations and Calculations:**

Horizontal Distance, D (m) = Staff Intercept, S (m) =

$$D = KS + C$$

**Result:**

For the given instrument

f/i = multiplying constant (K) = f+d = Additive constant (C) =

**Comments/Inference:**

Write your comments and observations on the result obtained.

# **SETTING OUTWORKS**

## **SETTING OUT WORKS**

### **INTRODUCTION**

Setting out is a survey undertaken in order to transfer onto the site the plans prepared as a result of some previous survey. Setting out, in a sense, is the reverse of the conventional surveying. Here, instead of using data from the site to prepare plans, the plans and designs prepared by the designer are transferred accurately onto the actual site. It may be described as the fixing of well-defined points in the field showing the horizontal and vertical positions required by the plans.

To build according to the plan, a contractor must have reference lines and points established in the field. This involves placing of pegs or marks to define the lines and levels of work where after, the construction proceeds according to these marks. Some factors to be considered during setting out works are:

1. The reference lines and points should be well defined, not easily perishable, close to the work yet out of the way of actual construction operations.
2. A very high degree of accuracy should be maintained and only extremely low tolerances should be allowed. In order to achieve this, frequent and independent checking should be done.
3. The instruments used should be checked frequently and discrepancies, if any, should be removed.

In most of the setting out works, the principle is very simple, but in practice, difficulties like skew plans, obstructions, etc. are encountered which often necessitate the use of indirect methods. The use of surveying methods provides the tool for layout or setting out works as well as the control which makes the proper layout possible.

The contemporary construction scenario encompasses a wide variety of structures. As such, it will be impossible to cover every conceivable setting out problem in this book. Instead, a few more common and important ones are discussed herein.

## **DEFINITIONS**

Some terms which are used frequently in setting out works are defined below.

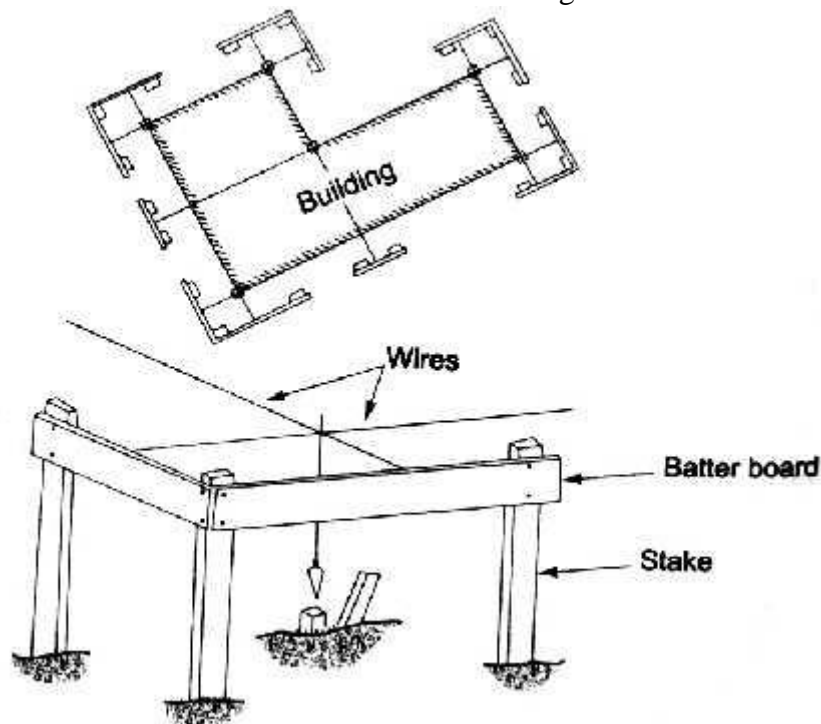
**Stake:** The term stake refers to any type of keel, which is driven into the ground so as to act as a permanent identification mark. Stakes may be made of timber, steel, copper, etc. Generally, these are pointed at one end to facilitate their anchoring into the ground. Depending upon the purpose it serves, it is termed as *guard, grade, or line stake*.

**Post:** In the setting out works, post is used to refer to any circular or square pole, generally wooden, which is used for various purposes, e.g. acting as a peg to support horizontal members like sight rails.

**Batter-board:** This is also known as a slope rail. In setting out works of large magnitudes, where absolute accuracy is required, batter-boards are used in conjunction with the wooden stakes or pins. A batter-board is generally a flat, square, wooden board, which is forced on top of a pin anchored in ground. Nails are driven in this board to indicate the direction of various lines that may give the

boundary of a building, mark of an excavation, etc. Strings or wires can be stretched between two batter-boards using the nails driven in them.

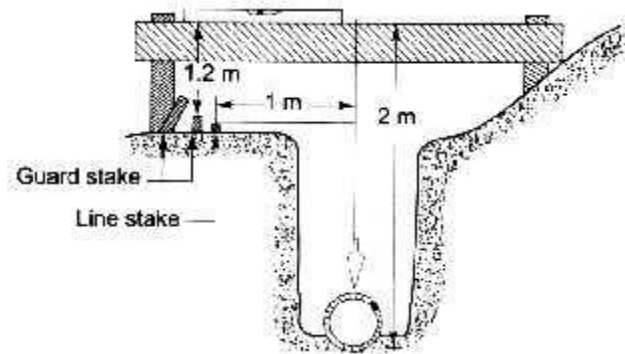
Batter-boards and wires over wooden stakes as shown in Fig.25.



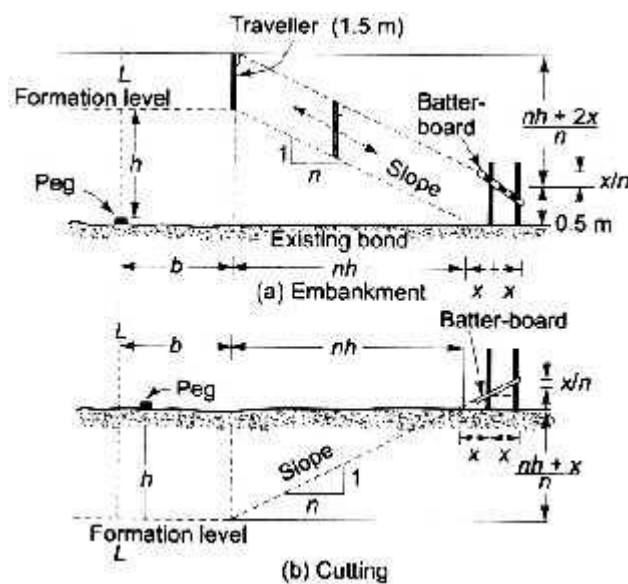
**Fig.25 Batter-Boards and Wires Over Wooden Stakes**



Batter board for a pipeline as shown in Fig.26.



**Fig.26 (a) Batter-board for a Pipeline**

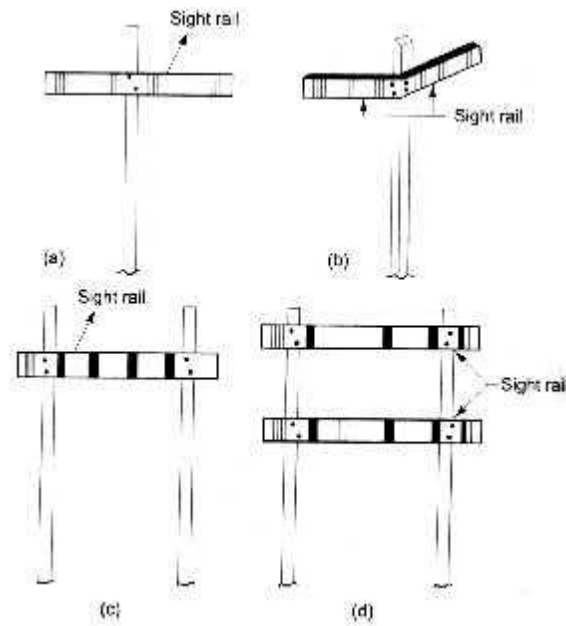


**Fig.26 (b) Use of Batter-Board**

**Crosshead:** A crosshead consists of two vertical posts 1-1.5 m high, firmly embedded in ground, on each side of the trench with a horizontal rail nailed to these posts across the trench.

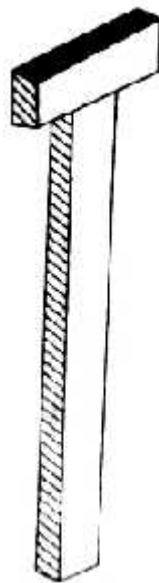
**Sight Rails:** The horizontal member of the crosshead, i.e. the timber beam nailed to the posts is referred to as a sight rail. A sight rail is in itself a kind of batter-board. The upper edge of the crosspiece is set to a convenient height above the ground so that a surveyor may align his eye with the upper edge. A single sight rail is used for road works, footings, etc., whereas two

sight rails at right angles are used for building corners. For trenches and large diameter pipes, sight rail is used. Sight rail shown in Fig.27 is used for highly undulating and steep grounds.

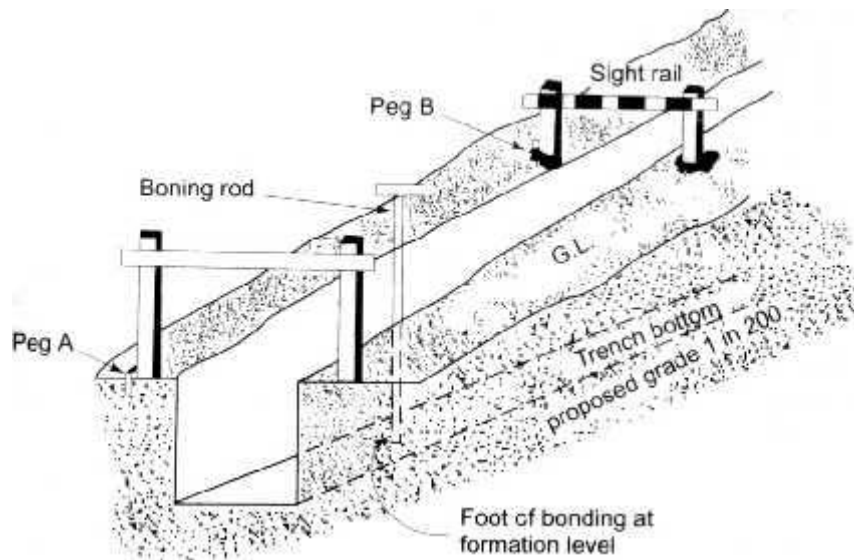


**Fig.27 Sight Rails**

**Boning Rod:** It is a T-shaped wooden rod as shown in Fig.28. The top piece is generally 10cm x 40 cm and is 3 cm thick. This is nailed to an upright pole. It is generally used in the layout of trenches for sewers, pipe lines, etc. The length of aboning rod for each trench section is kept the same.

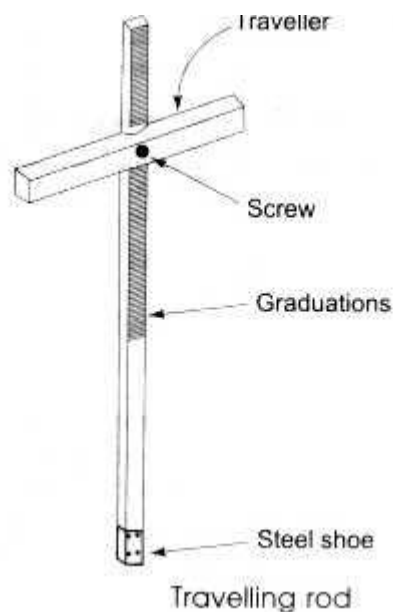


**Fig.28 (a) Boning Rod**



**Fig.28 (b) Use of Boning Rod**

**Travelling Rod:** A traveling rod (Fig.29) is a special type of boning rod in which the horizontal piece, called *traveler*, can be moved along a graduated vertical staff and can be conveniently clamped at any desired height.



**Fig.29 Travelling Rod**

**Precautions**

- 1) Hold the tape such that it is in horizontal plane.
- 2) Hold the cross staff over the point in perfectly vertical position.
- 3) Use wooden or MS pegs for marking the points.
- 4) Place the batter board & sight-rails in horizontal position using the spirit level.

**Aim:** To set out work for a given plan of a building.

**Equipment:**

Cross-Staff, Spirit Level, 30m Tape, 5m Pocket Tape, Pegs, Wooden Stakes And Threads/Wire/Rope.

**Principle:**

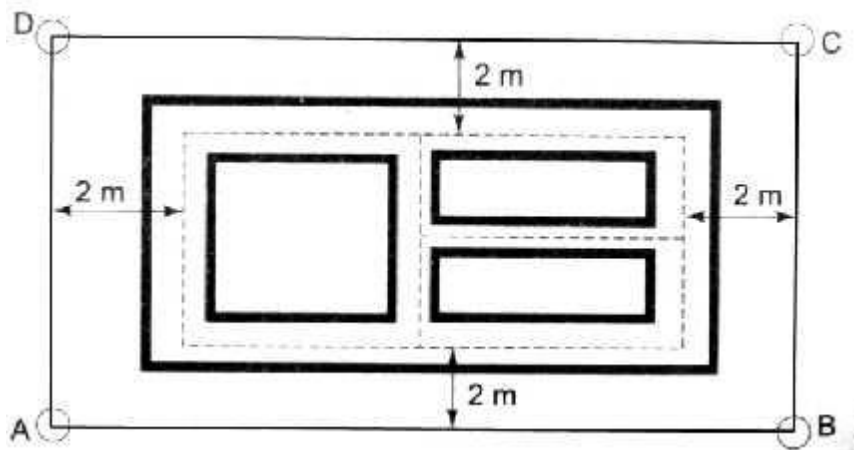
Setting out of a building involves the transfer of the architect's plan from paper onto the actual site. The object of setting out a building is to provide the builder with clearly defined outlines for excavations. Two methods are generally used for setting out a building.

**Procedure:**

***By using a circumscribing rectangle***

Since stakes cannot be set at the exact corner points of a building (if set so, these will be lost during excavations), these are fixed at the corners of a bigger rectangle circumscribing the actual chosen, but a distance of usually 2-4 m is considered to be ideal. The actual procedure consists of the following steps:

1. Preparation of the foundation trench plan showing the width of the foundations for various walls.
2. Temporary pegs are driven at the actual corner points of the building.
3. Then using these pegs as reference, a parallel line, say AB as shown in Fig.30 of required length is set out at an arbitrarily selected distance (say 2m) from the actual center line.
4. A chord is stretched between the pegs A and B. At A, a line is set out perpendicular to AB (with a tape using 3, 4, 5 method). On this line, the position D is marked by setting a peg.
5. Step (d) is repeated at point B so as to obtain point C.
6. Having now set out the reference rectangle ABCD, the actual corners can be marked using the sides of the reference rectangle ABCD.
7. Once all the points are staked, a chord is passed around the periphery of the rectangle and the actual excavation lines are marked using lime.



**Fig.30 Setting-out Structures by Using a Circumscribing Rectangle**

**Checks:**

In steps (d) and (e), after marking points D and C, respectively, the diagonals BD and AC should be measured. These lengths should correspond to the distances on the plan.

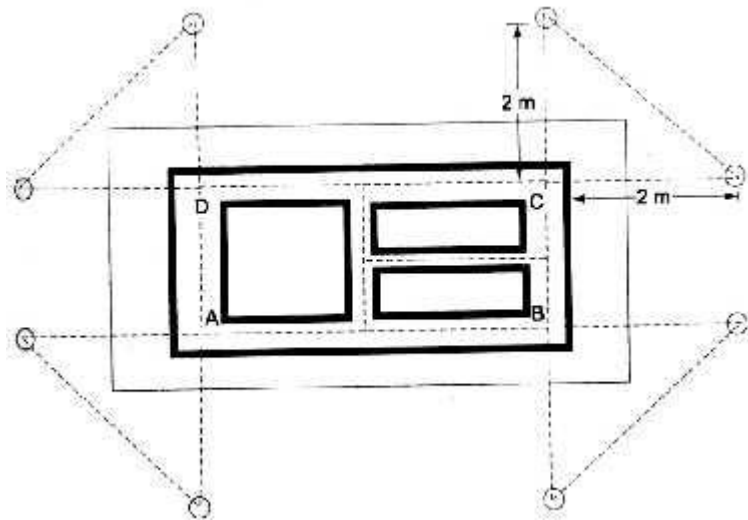
After setting out the point C, the length CD should be measured and should be exactly same as that of AB.

***By making use of the rectangle formed by centerlines of the outer walls of a building***

In this method the rectangle formed by the centerlines of the outer walls of the building is used.

The steps involved are:

1. The temporary stakes are fixed at the points that represent the corners of the center line rectangle. The procedure is similar to the one used in the first method while plotting the circumscribed rectangle.
2. Since these pegs are not permanent and will be lost during excavation, the sides of the rectangle are produced on both the sides and permanent stakes are fixed on each of the prolongations, at a fixed distance, say 2m, as shown in Fig.31.
3. By using these stakes, the position of any point can be obtained by plotting its coordinates using the reference stakes.



**Fig.31 Setting-out by Using Rectangle Formed by Centerlines of the Outer Walls of a Building**

# **TOTAL STATION**

## TOTAL STATION

### INTRODUCTION

Total Station is three-dimensional surveying technology unit. Total station combines the follow three basic components into one integral unit (Fig.32).

1. an electronic distance measurement instrument
2. an electronic digital Theodolite
3. a computer or microprocessor

Total station can automatically measure horizontal and vertical angles as well as slope distances from a single setup. From these data it can instantaneously compute:

1. horizontal and vertical distance components
2. elevations
3. coordinates

and display the results on an LCD.

Total station can also store data either on board in internal memory or in external data collectors. Data can be uploaded and can be downloaded to a computer. It can also perform basic co-ordinate geometry functions like area and perimeter calculations.

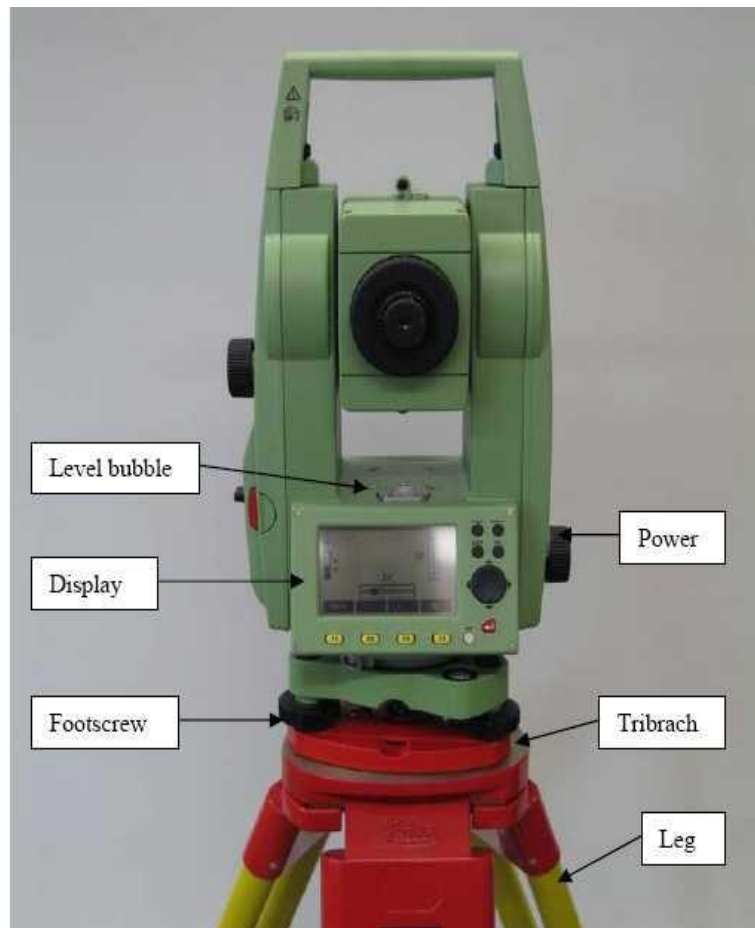
**Distance Measurement:** When a distance is measured with a total station a electromagnetic pulse is used for measurement – this is propagated through the atmosphere from instrument to a prismatic reflector or target and back during measurement. Distances are obtained by measuring the time taken for a laser radiation to travel from the instrument to a prism (or target) and back. The pulses are derived from an infrared or visible laser diode and they are transmitted through the telescope towards the remote end of the distance being measured, where they are reflected from a reflector and return to the instrument. Since the velocity  $v$  of the pulses can be accurately determined, the distance  $D$  can be obtained using  $2D = vt$ , where  $t$  is the time taken for a single pulse to travel from instrument-target-instrument. This is also known as the timed-pulse or time of flight measurement



technique, in which the transit time  $t$  is measured using electronic signal processing technique.

When measuring distances to a reflector telescope uses a wide visible red laser beam, which emerges coaxially from the telescope's objective.

When reflector less measurements are made telescope uses a narrow visible red laser beam which emerges coaxially from the telescope's objective



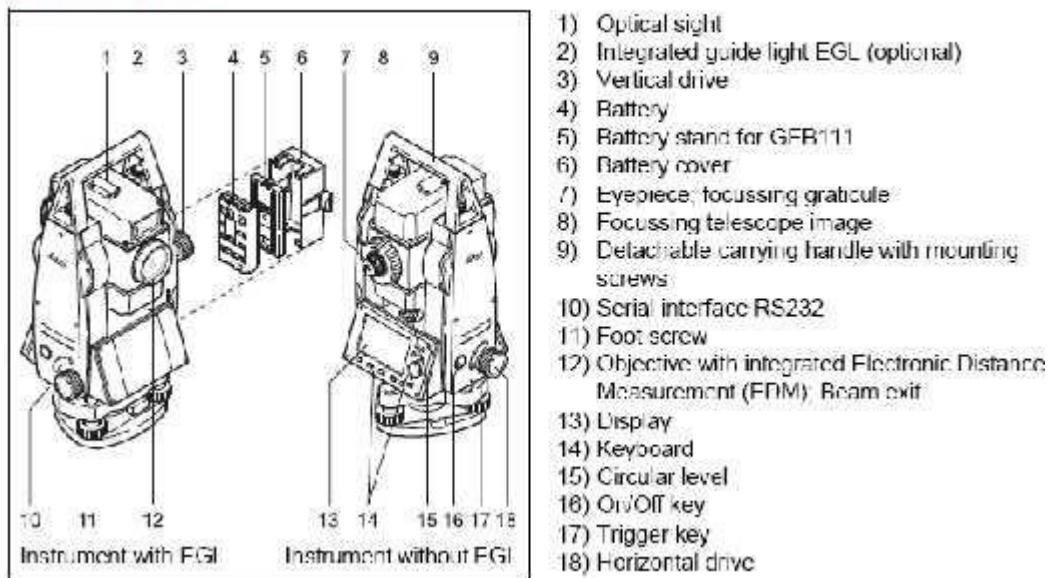
**Fig.32 Total Station**

## PRECAUTIONS

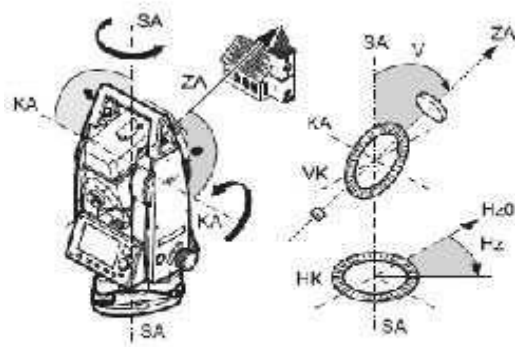
Total stations are *very* expensive and can be damaged by forcing or dropping the equipment. Please be extremely careful with this expensive equipment and make sure it does not get wet.

1. Never Place the Total Station directly on the ground.
2. Do not aim the telescope at the sun.
3. Protect the Total Station with an umbrella.
4. Never carry the Total Station on the tripod to another site
5. Handle the Total Station with care. Avoid heavy shocks or vibration.
6. When the operator leaves the Total Station, the vinyl cover should be placed on the instrument.
7. Always switch the power off before removing the standard battery.
8. Remove the standard battery from the Total Station before putting it in the case.
9. When the Total Station is placed in the carrying case, follow the layout plan.

### Important parts



## Technical terms and abbreviations



### **ZA = Line of sight / collimation axis**

Telescope axis = line from the reticle to the centre of the objective

### **SA = Standing axis**

Vertical rotation axis of the telescope.

### **KA = Tilting axis**

Horizontal rotation axis of the telescope (Trunion axis).

### **V = Vertical angle / zenith angle**

### **VK = Vertical circle**

With coded circular division for reading the V angle.

### **Hz = Horizontal direction**

### **HK = Horizontal circle**

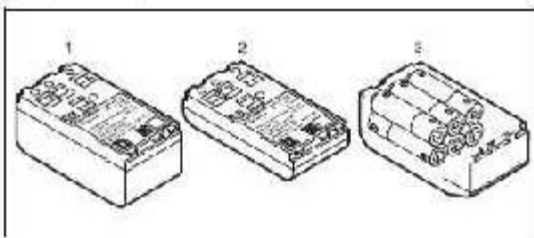
With coded circular division for reading the Hz-angle.

## Power Supply

Use the Leica Geosystems batteries, chargers and accessories or accessories recommended by Leica Geosystems to ensure the correct functionality of the instrument.

Power for the instrument can be supplied either internally or externally. An external battery is connected to the instrument using a LEMO cable.


- **Internal battery:**  
One GLB111 or 121 battery fit in the battery compartment.
- **External battery:**  
One GEB171 battery connected via cable.



- 1 GEB121
- 2 GLB111
- 3 Single cells in the battery adapter GAD39


Your Leica Geosystems instrument is powered by rechargeable plug-in batteries. For this product, we recommend the basic battery (GEB111) or the Pro battery (GEB121). Optionally six single cells can be used with the GAD39 battery adapter.

Six single cell batteries (1.5 V each) supply 9 Volts. The voltmeter on the instrument is designed for a voltage of 6 Volts (GEB111/ GEB121).

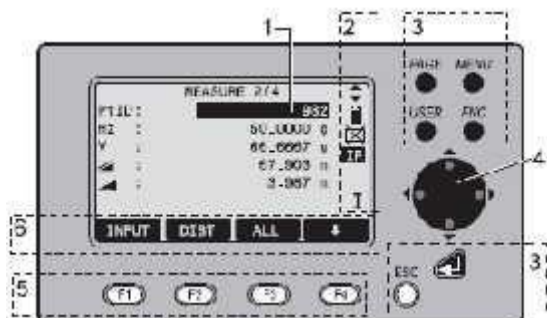
 The battery charge is not displayed correctly when using single cells. Use the single cells with the battery adapter as emergency power supply. The advantage of the single cells is in a lower rate of discharge even over long periods.

## Operating the Instrument

The On / Off key is located on the side cover of the TPS407.


 All shown displays are examples. It is possible that local software versions are different to the basic version.

## Keypad



- 1) Focus  
Actively measured field
- 2) Symbols  
Keys with firmly assigned functions.
- 3) Fixed keys  
Keys with firmly assigned functions.
- 4) Navigation keys  
Control of input bar in edit and input mode or control of focus bar.
- 5) Function keys  
Are assigned the variable functions displayed at the bottom of the screen.
- 6) Softkey bar  
Displays functions that can be called up with the function keys.

### Fixed keys

- [PAGE] Scrolls to next page when a dialogue consists of several pages.
- [MENU] Accesses programs, settings, the data manager, adjustments, communications parameters, system information and data transfer
- [USLR] Key, programmable with function from the FNC menu.
- [FNC] Quick-access to measurement-supporting functions
- [ESC] Quit a dialog or the edit mode with activation of the "previous" value. Return to next higher level.
-  Confirm an input, continue to the next field.

---

### Trigger key

The measurement trigger has three settings (All, DIST, OFF).

The key can be activated in the configuration menu

---

### Selection of Language

After switching on the instrument the user is able to choose his preferred language.

The dialog to choose the language is only shown if two languages are loaded onto the instrument and **Lang.choice: On** is set in Settings dialog.


To load an additional language connect the instrument to LGO Tools Version 4.0 or higher via the serial interface and load using "LGO Tools - Software Upload".

---

### Distance measurement


A laser distancer (EDM) is incorporated into the instruments of the TPS400 series.

In all versions, the distance can be determined by using a laser beam which emerges coaxially from the telescope objective.

 **Measurements to strongly reflecting targets such as to traffic lights in Reflector EDM mode without prism should be avoided. The measured distances may be wrong or inaccurate.**

For applications without reflector, a special arrangement of the LDM, and appropriate arrangement of the beam paths, enable ranges of over five kilometres to be attained with standard prisms.


Miniprisms, 360° reflectors and reflector tapes can also be used, and measurement is also possible without a reflector.

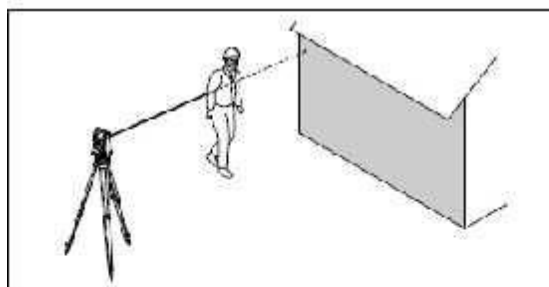
 **When a distance measurement is triggered, the EDM measures to the object which is in the beam path at that moment.**

If e.g. people, cars, animals, swaying branches, etc. cross the laser beam while a measurement is being taken, a fraction of the laser beam is reflected and may lead to incorrect distance values.

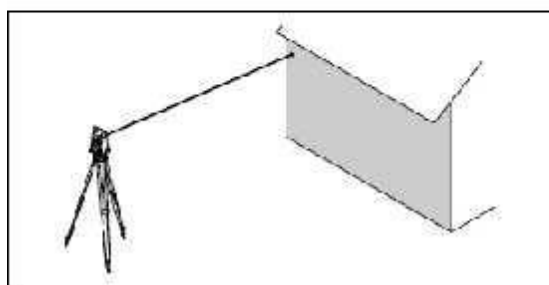
Avoid interrupting the measuring beam while taking reflectorless measurements or measurements using reflective foils. Measurements to prism reflectors are only critical if an object crosses the measuring beam at a distance of 0 to 30m and the distance to be measured is more than 300m.

In practice, because the measuring time is very short, the user can always find a way of avoiding those critical situations.

 Very short distances may be measured reflectorless in IR mode to well reflecting targets. Note that the distances are corrected with the additive constant defined for the active reflector



Incorrect result



Correct result

### Reflectorless

☞ Be sure that the laser beam is not reflected by anything close to the line of sight (e.g. highly reflective objects).

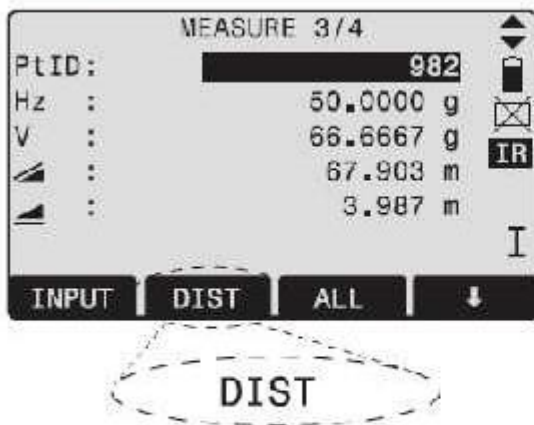
☞ When a distance measurement is triggered, the EDM measures to the object which is in the beam path at that moment. In case of temporary obstruction (e.g. a passing vehicle, heavy rain, fog or snow) the EDM may measure to the obstruction.

☞ When measuring longer distances, any divergence of the red laser beam from the line of sight might lead to less accurate measurements. This is because the laser beam might not be reflected from the point at which the crosshairs are pointing.

Therefore, it is recommended to verify that the laser is well collimated with the telescope line of sight (refer to the chapter "Checking and adjusting").

☞ Do not measure with two instruments to the same target simultaneously.

### Softkeys



Under softkeys, a selection of commands and functions is listed at the bottom of the screen. They can be activated with the corresponding function keys. The available scope of each function depends on the applications / functions currently active.






### General softkeys:

- [ALL] Starts distance and angle measurements and saves measured values
- [DIST] Starts distance and angle measurements without saving measured values.
- [REC] Saves displayed values.
- [FNTR] Deletes current value in the display and is ready for the input of a new value.
- [ENH] Opens the coordinate input mode.
- [LIST] Displays the list of available points.
- [FIND] Starts the search for the point entered.
- [EDM] Displays EDM settings.
- [IR/IR] Toggles between reflector and reflectorless measurement modes.
- [PREV] Back to last active dialog.
- [NEXT] Continue to next dialog.
- ← Returns to highest softkey level
- ↓ To next softkey level
- [OK] Set displayed message or dialog and quit dialog.

☞ Find further information about menu/application specific buttons in the relevant sections.

## Symbols

Depending on software version different symbols are displayed indicating a particular operating status.

-  A double arrow indicates choice fields.
-  Using the navigation keys the desired parameter can be selected.
-  Cancels a selection with the enter key or the navigation keys
-  Indicates that several pages are available which can be selected with [PAGE].
- I, II** Indicates telescope position I or II.
-  Indicates that I or II is set to "left side angle measurement" (anti clockwise).

## Status symbol "EDM type"



Reflector EDM mode for measuring to prisms and reflective targets.



Reflectorless EDM for measuring to all targets.

## Status symbol "Battery capacity"



The battery symbol indicates the level of the remaining battery capacity (75% full shown in the example)

## Status symbol "Compensator"



Compensator is on



Compensator is off


## Status symbol "Offset"

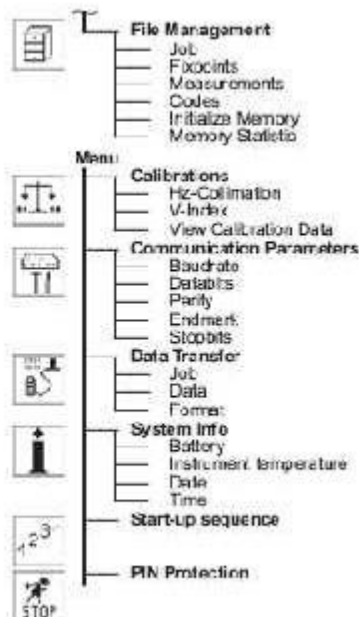
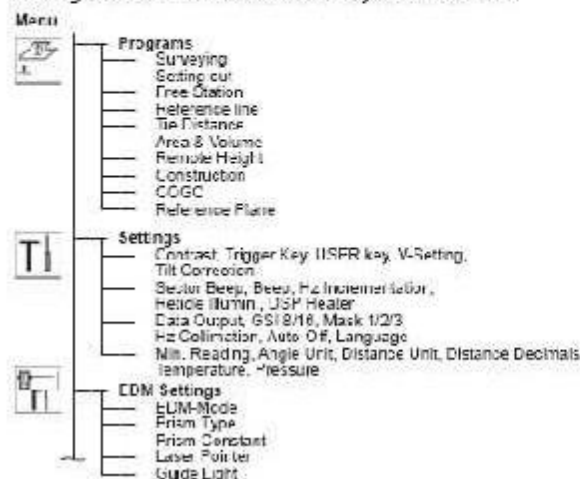


Offset is active

## Menu tree

[MENU] > **F1** - **F2** Confirm menu selection.  
[PAGE] Scroll to next page.

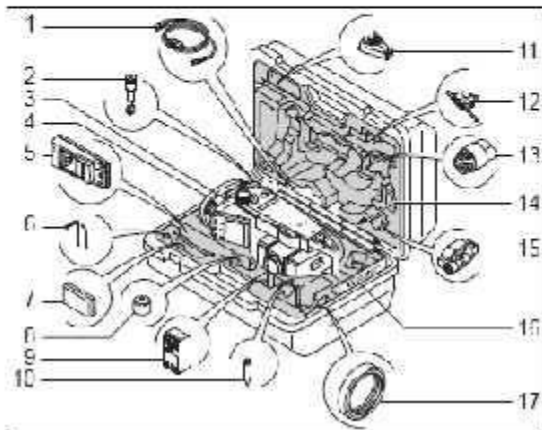
 Depending on user interface sequence and arrangement of menu items may be different.



## Measuring Preparation / Setting up

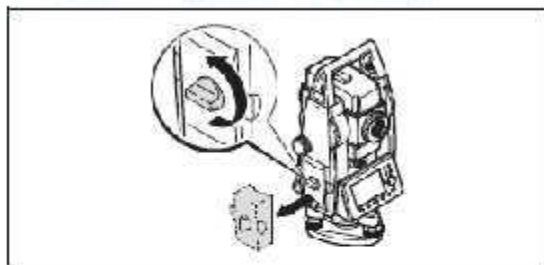
### Unpacking

Remove TPS400 from transport case and check for completeness.

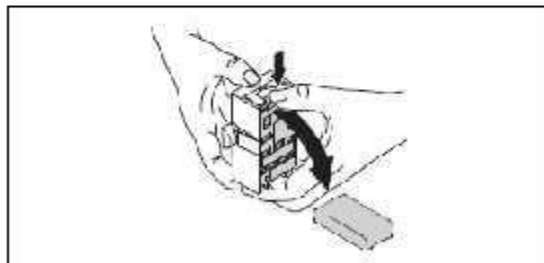


- 1) Data cable (optional)
- 2) Zenith eyepiece or eyepiece for steep angles (optional)
- 3) Total station
- 4) Removable tribrach (optional)
- 5) Battery charger and accessories (optional)
- 6) Adjustment tools
- 7) Battery GI 13111 (optional)
- 8) GAD 105 Mini prism adapter (optional)
- 9) Battery GEB121 (optional)
- 10) Tip for mini prism (optional)
- 11) Spacing bracket GHT196 for height meter (optional)
- 12) Height meter GHM007 (optional)
- 13) Protective cover / Lens hood
- 14) Mini prism rods
- 15) Mini prism + holder (optional)
- 16) User Manual
- 17) Counterweight for Zenith eyepiece (optional)

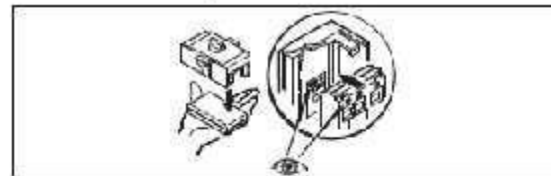
### Inserting / Replacing Battery



1. Remove battery holder.



2. Remove battery.



3. Insert battery into battery holder.



4. Insert battery holder into the instrument.

Insert battery correctly (note polar markings on the inside of the battery holder). Check and insert battery holder true to side into the housing.

- To charge the battery refer to chapter "Charging the batteries".
- For the type of battery refer to chapter "Technical data".



☞ When using the GEB121 battery, remove the spacer for the GEB111 from the battery compartment.

#### ☞ Charging / first-time use

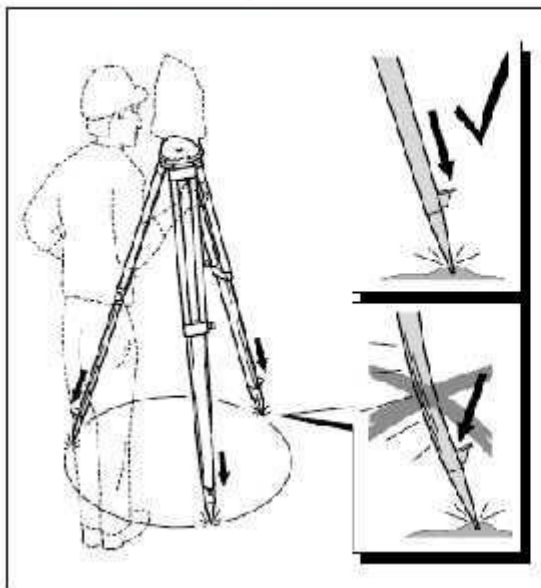
- The battery must be charged prior to using for the first time because it is delivered with an energy content as low as possible.
- For new batteries or batteries that have been stored for a long time (> three months), it is effectual to make 3 - 5 charge/discharge cycles.
- The permissible temperature range for charging is between 0°C to +35°C / +32°F to +95°F. For optimal charging we recommend charging the batteries at a low ambient temperature of +10°C to +20°C / +50°F to +68°F if possible.
- It is normal for the battery to become warm during charging. Using the chargers recommended by Leica Geosystems, it is not possible to charge the battery if the temperature is too high.

#### ☞ Operation/Discharging

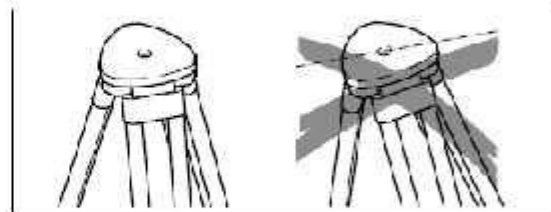
The batteries can be operated from -20°C to +55°C / -4°F to +131°F.

Low operating temperatures reduce the capacity that can be drawn; very high operating temperatures reduce the service life of the battery.

### Setting up the tripod

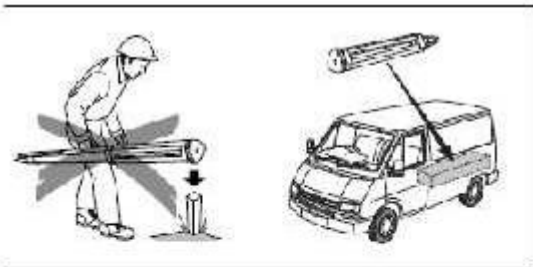


1. Loosen the clamping screws on the tripod legs, pull out to the required length and tighten the clamps.
2. In order to guarantee a firm foothold sufficiently press the tripod legs into the ground. When pressing the legs into the ground note that the force must be applied along the legs.



☞ When setting up the tripod pay attention to a horizontal position of the tripod plate. Slight corrections of inclination can be made with the foot screws of the tribrach. Larger corrections must be done with the tripod legs.

☞ When using a tribrach with an optical plummet, the laser plummet cannot be used.



#### Careful handling of tripod

- Check all screws and bolts for correct fit.
- During transport always use the cover supplied.
- Use the tripod only for surveying tasks

## Instrument Setup

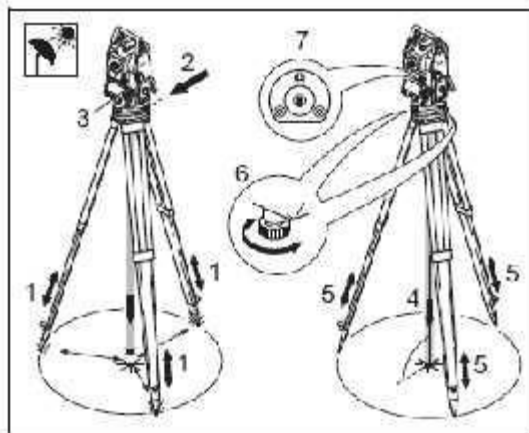
#### Description

This topic describes an instrument setup over a marked ground point using the laser plummet. It is always possible to set up the instrument without the need for a marked ground point.



- Important features:
  - It is always recommended to shield the instrument from direct sunlight and avoid uneven temperatures around the instrument
  - The laser plummet described in this topic is built into the vertical axis of the instrument. It projects a red spot onto the ground, making it appreciably easier to centre the instrument
  - The laser plummet cannot be used in conjunction with a tribrach equipped with an optical plummet.

#### Setup step-by-step




1. Extend the tripod legs to allow for a comfortable working posture. Position the tripod over the marked ground point, centring it as well as possible.
2. Fasten the tribrach and instrument onto the tripod.

3. Turn on the instrument and switch on the laser plummet and electronic level by pressing [FNC] > [Level/Plummet].
4. Move the tripod legs (1) and use the tribrach footscrews (6) to centre the plummet (4) over the ground point.
5. Adjust the tripod legs to level the circular level (7).
6. By using the electronic level turn the tribrach footscrews (6) to precisely level the instrument. Refer to "Levelling up with the electronic level step-by-step" for more information.
7. Centre the instrument precisely over the ground point (4) by shifting the tribrach on the tripod plate (2).
8. Repeat steps 6 and 7 until the required accuracy is achieved.

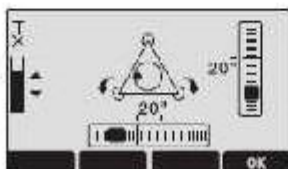
## Levelling up with the electronic level step-by-step

The electronic level can be used to precisely level up the instrument using the footscrews of the tribrach.

1. Turn on the instrument and switch on the electronic level by pressing [FNC] > [Level/Plumme].
2. Centre the circular level approximately by turning the footscrews of the tribrach.

 The bubble of the electronic level and the arrows for the rotating direction of the footscrews only appear if the instrument tilt is inside a certain levelling range.

3. Turn the instrument until it is parallel to two footscrews.
4. Centre the electronic level of this axis by turning the two footscrews. Arrows show the direction for




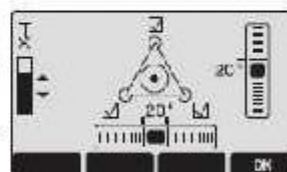
rotating the footscrews. When the electronic level is centred the arrows are replaced by checkmarks.

5. Centre the electronic level for the second axis by turning the last footscrew. An arrow shows the direction for



rotating the footscrew. When the electronic level is centred the arrow is replaced by a checkmark.

 When the electronic level is centred and three checkmarks are shown, the instrument has been perfectly levelled up.

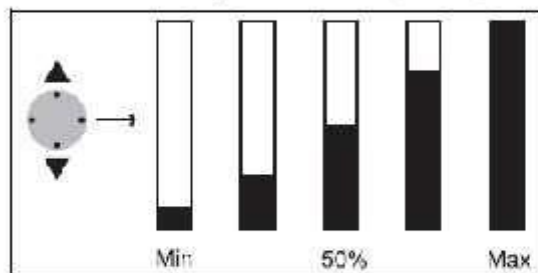


6. Accept with [OK].

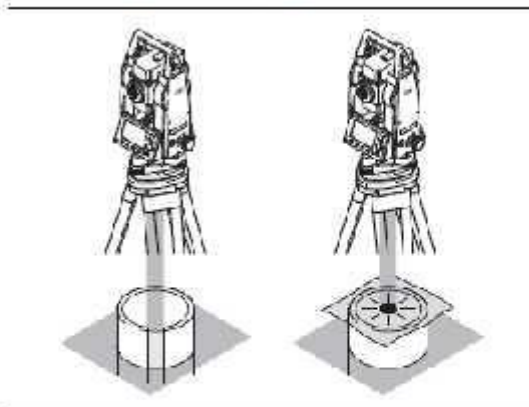
## Laser intensity

### Changing the laser intensity

External influences and the surface conditions may require the adjustment of the intensity of the laser. The laser can be adjusted in 25% steps as required.



## Hints for positioning

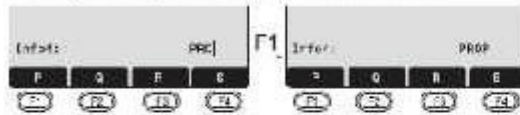


### Positioning over pipes or depressions

Under some circumstances the laser spot is not visible (e.g. over pipes). In this case, the laser spot can be made visible by using a transparent plate so that the laser spot can be easily aligned to the centre of the pipe.

## Input mode - method 1

In entry mode, enter text or numeric values.




[INPUT] 1. Delete entry, display numeric/ alpha numeric softkey bar. The cursor indicates that the instrument is ready for input.

**F1** - **F3** 2. Selection of range of characters/ range of numbers

[>>>] Additional characters/ numbers.

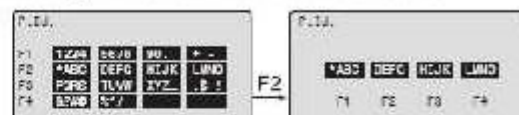
**F1** - **F3** 3. Select the desired character. Character shifts to the left.

 4. Confirm entry.

[ESC] Deletes input and restores previous value.

## Input mode - method 2


In entry mode, enter text or numeric values.



[INPUT] 1. The full range of available characters are displayed on the screen.

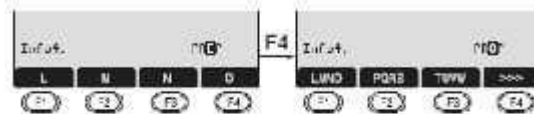
**F1** - **F4** 2. Selection of range of characters/ range of numbers


Proceed with steps 3 and 4 from method 1.


 The method you like to use can be set in the settings.

## Edit mode

Existing characters are changed in the edit mode.




 1. Start edit mode. Vertical edit bar is positioned flush right.

 Edit bar is positioned flush left.

**F1** - **F3** 2. Select range of characters/ range of numbers


[>>>] Additional characters / numbers.


**F1** - **F3** 3. Overwrite existing characters.


 4. Confirm input.

[ESC] Deletes change and restores previous value.

## Erasing characters

 1. Place cursor on character to be deleted.

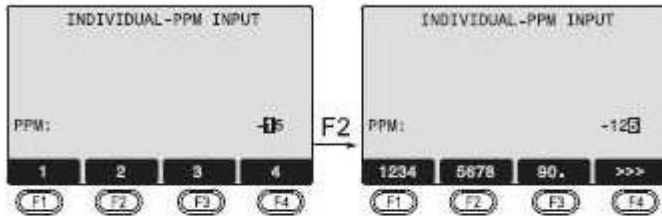
 2. Pressing the navigation key deletes the relevant character

 3. Confirm input

[ESC] Deletes the change and restores the previous value

## Inserting characters

If a character was skipped (e.g. -15 instead of -125) you can insert it later.



1. Place cursor on "1".
2. Inserts an empty character on the right of "1".
3. Select range of characters /range of numbers.
4. Select relevant character.
5. Confirm input.

## Numerical and Alphanumerical input

Input is made with the softkey bar and the assigned function keys.

Position the marker in the relevant field.

[INPUT] 1. Calls up the input dialogue.

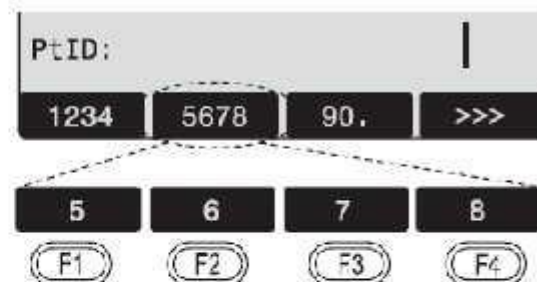
2. Select range of characters /range of numbers.

[>>>] Additional characters / numbers.

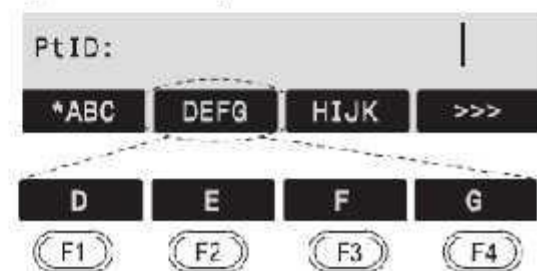
3. Confirm input.

Selection is limited to valid digits for entries, that due to their display characteristics, fall into a certain range (e.g. angles in degrees).

### Numerical input



### Alphanumerical input



---

### Pointsearch

Pointsearch is a global function used by applications to e.g. find internally saved measured or fixed points.

It is possible for the user to limit the point search to a particular job or to search the whole storage. The search procedure always finds fixed points before measured points that fulfill the same search criteria. If several points meet the search criteria, then the points are listed according to their age. The instrument finds the most current (youngest) fixed point first.

#### Direct search

By entering an actual point number (e.g. "P13") all points with the corresponding point number are found.

```
POINT SEARCH
Job :          ALL JOBS ◀▶
PtID:          P13
P13           FIXPT
P13           MEAS
P13           MEAS
VIEW  JOB   OK   ↓
```

[VIEW]	Displays the coordinates and the job of the selected point.
[ENTER]	For manual input of coordinates.
[OK]	Confirm selected point.
[JOB]	To select a different job.

---

### Wildcard search

The Wildcard search is indicated by a "\*". The asterisk is a place holder for any following sequence of characters.

Wildcards are always used if the point number is not fully known, or if a batch of points is to be searched for.

- \*1 All points of any length with a "1" as the second character are found (e.g., A1, B12, A1C).
- A\*1 All points of any length with an "A" as the first character and a "1" as the third character are found. (e.g.: AB1, AA100, AS15).

```
POINT SEARCH
Job :          PROJ 3 ◀▶
PtID:          A*1
```

 Starts point search.

#### Examples:


- \* All points of any length are found.
  - A All points with exactly the point number "A" are found.
  - A\* All points of any length starting with "A" are found (e.g.: A9, A15, A1000).
-

---

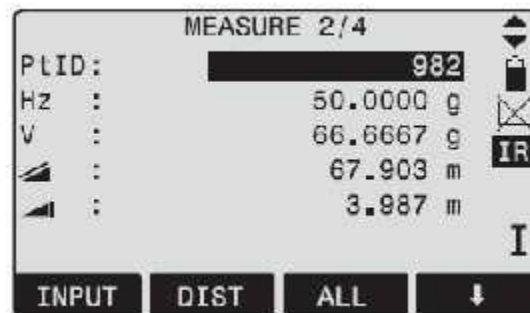
## Measuring

After switching on and setting up correctly, the total station is immediately ready for measuring.

In the measurement display it is possible to call up fixed keys and function keys, as well as trigger keys and their functions.

 All shown displays are examples. It is possible that local software versions are different to the basic version.

Example of a possible measuring display:





**F1** - **F4** Calling up the assigned function

---

## FNC Key

Under [FNC] several functions can be called up. Their applications are described below:

 Functions can also be started directly from the different applications.

 Each function from the FNC menu can be assigned to the [USER]-key (see chapter "Settings").

---

### Light On /Off

Switches display light on / off.

---

### Level/Plummet

This function enables the electronic bubble and the range of intensity settings of the laser plummet.

---

### IR/ RL Toggle

Change between the two EDM types IR (on Reflectors) and RL (Reflectorless). New setting is displayed for about one second.

IR: Distance measurements with prisms.

RL: Distance measurements without prisms.

Find more information in chapter "EDM Settings".

---

### Laser Pointer

Switches on or off the visible laser beam for illuminating the target point. The new settings are displayed for about one second and then saved.

---

### Free-Coding

Starts "Coding" to select a code from a codelist or enter a new code. Some functionality like softkey button [CODE].

---

### Units

Displays the current distance and angle unit and gives the possibility to change these.

---

## BASIC STEPS INVOLVED IN SETTING UP A TOTAL STATION

### SETTING UP TOTAL STATION OVER A POINT FOR THE FIRST TIME(Aligning to North)

- Switch on the instrument.
- Press USER key for Laser Beam for centering and leveling.
- Press MENU.
- Press **F1 (PROGRAMS)**.



1. Press **F1 (SURVEYING)**.



2. Press **F1 (Set Job)**.



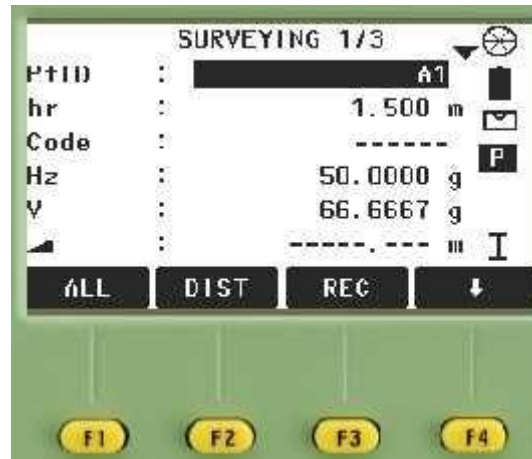


3. Press **F1 (NEW)** to give a new job name.
4. To write the name of the job. Press **F1 (INPUT)** and then using the Functionkeys **F1** to **F4** give the name. Then Press **Enter**.
5. Press **F4 (OK)**
6. Press **F2 (Set Station)** to give the station No. Press **F1 (INPUT)** to give the station number using the Function keys from **F1** to **F4**.
7. Press **F2 (FIND)**.
8. Press **F4 (ENH)**.
12. Enter the Easting, Northing and Elevation for the point and Press **F4 (OK)**
13. Now in front of **hi (Instrument Height)** give the height of the instrument.
14. Press **F4 (OK)**
14. Press **F3 (Set Orientation)**.

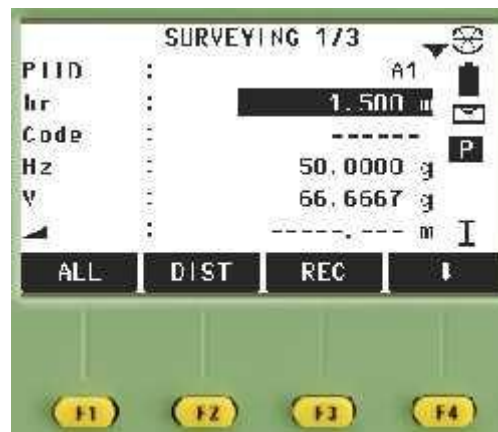


15. Press **F1 (Manual Angle Setting)**.
16. Point the instrument in the North direction and Press **F1 (Hz=0)**.
17. Press **F3 (REC)**.

18. Press **F4 (START)**.



19. In front of the **(Pt ID) Point ID** give the number of the point to shoot.



20. In front of the **hr (Reflector height)** give the height to which the reflector is opened.

**2. FOR SHIFTING THE STATION BY ALIGNING TO THE BACK POINT (Known Co-ordinates)**

1. Switch on the instrument.
2. Press USER key for Laser Beam for centering and leveling.
3. Press MENU.
4. Press **F1 (PROGRAMS)**.
5. Press **F1 (SURVEYING)**.
6. Press **F2 (Set Station)** to give the station No.
7. In front of Station: Enter the Station Number where you are standing. Press **F1 (INPUT)** to give the station number using the Function keys from **F1 to F4**.  
Press **F2 (FIND)**.
8. Press **F4 (OK)**.
9. Now Give in front of **hi (height of Instrument)** and Press **F4 (OK)**.
10. Press **F3 (Set Orientation)**.
11. Press **F2 (Coordinates)**.
12. In front of **BS (Back Sight)** give the number of the Back Point to which the Instrument is being aligned. By Pressing **F1 (INPUT)**
13. Press **F2 (FIND)**
14. Press **F4 (OK)**.
15. Press **PAGE**.
16. Now Sight the back point and Press **F1 (DIST)**.
17. The value in front of  $\square =$  will give the relative error in station shifting.
18. Press **F3 (REC)**.
19. Now Press **F (OK)**.
20. Press **F4 (START)**
20. And we can continue with the surveying.
21. To see the Easting, Northing, and Elevation for a Point Press **PAGE** until you see East, North, Elevation.

## B.Tech. IV Semester

### **ADVANCED SURVEYING LAB (4CE4-24)**

#### **Session 2022-23**

#### **Viva**

1. What is the principal of Surveying?

**Answer:** If you have studied the Surveying or if you are still studying, then this is the one of the first question which you should know. When ever you have to do any kind of survey you have to do it from whole to parts. It is the first principle of Surveying.

Initially main control points are established with very high accuracy at the far distances to cover whole the area and then using these points as the reference points you establish the secondary and tertiary control points.

Second principle of Surveying which you should know is that any point can be established or located precisely with reference to a minimum of two another reference points. That means you need at least two reference points to locate one another point.

2. What is the principal of chaining?

**Answer:** You must know that if you have to do the survey only with the help of chaining then it is done by triangulation. You have to divide the area into a numbers of triangles and measure its sides with the chain or tape.

3. What is the height of a ranging rod and what is its diameter?

**Answer:** I think you will be rarely asked this question but putting a variety of ammunition always helps. Generally the height of a ranging rod is 2.4m but it may be varied up to 6m and its diameter is generally 1 inch. There are strips in red and white or red and yellow in the longitudinal direction which are generally 1ft length(30.5cm).

4. What is the purpose of a level?

**Answer:** You know that level can be used for the levelling or sometimes for contouring too. So the basic purpose of a level is to provide a horizontal line of sight.

5. What is the least count of a Theodolite?

**Answer:** You have to measure the horizontal and vertical angles using the Theodolite, so you must know that least count is 10" to 20" (seconds) for a vernier theodolite but for a micro-meter theodolite least count may be as small as 0.1" .

6. What are the sources of local attraction in Surveying?

**Answer:** First of all you must know that this term is related to the compass survey. Sometimes when you are doing the compass survey at places where there are materials which attract a magnetic needle of the compass, the magnetic needle fails to show the magnetic North accurately due to the attraction forces of these materials and therefore it will be deflected from true magnetic meridian.

It is important for you to know such materials which, may cause this error, right? This material can be a chain, a wrist band, a ring in your finger, belt tide to your trouser, a hair band, a nearby electric pole or anything which attracts a magnet, so it might be needed for you know about magnets too.

1. What is Surveying?

**Answer:** Surveying is an art of making measurements on as will determine the relative position of different points on the surface of the earth.

2. What is Leveling?

**Answer:** Levelling is the art of determining and representing the relative heights or elevations of different points on the surface of earth.

3. Objective and Uses of Surveying?

**Answer:** As stated in the definition, object of surveying is to show relative positions of various objects of an area on paper and produce plan or map of that area.

Various uses of surveying are listed below:

- (i) Plans prepared to record property lines of private, public and government lands help in avoiding unnecessary controversies.
- (ii) Maps prepared for marking boundaries of countries, states, districts etc., avoid disputes.
- (iii) Locality plans help in identifying location of houses and offices in the area.
- (iv) Road maps help travellers and tourist.
- (v) Topographic maps showing natural features like rivers, streams, hills, forests help in planning irrigation projects and flood control measures.
- (vi) For planning and estimating project works like roads, bridges, railways, airports, water supply and waste water disposal surveying is required.
- (vii) Marine and hydrographic survey helps in planning navigation routes and harbours.
- (viii) Military survey is required for strategic planning.
- (ix) Mine surveys are required for exploring minearl wealth.
- (x) Geological surveys are necessary for determining different strata in the earth crust so that proper location is found for reservoirs.
- (xi) Archeological surveys are useful for unearthing relics of antiquity.
- (xii) Astronomical survey helps in the study of movements of planets and for calculating local and standard times.

#### 4. Methods of Surveying?

**Answer:** a. Triangulation

b. Traversing

#### 5. Explain:

a. Topographic Map

b. Cadastral Map

c. Engineering Map

d. Military Map

e. Contour Map

f. Geological Map

g. Archeological Map

## 6. General Principle of Surveying?

**Answer:** The general principles of surveying are:

1. To work from the whole to the part
2. To locate a new station by at least two measurements (linear or angular) from fixed reference points.

According to the first principle, the whole area is first enclosed by main stations (i.e. Controlling stations) and main survey lines (i.e. controlling lines). The area is then divided into a number of parts by forming well conditioned triangles. A nearly equilateral triangle is considered to be the best well-conditioned triangle. The main survey lines are measured very accurately with a standard chain. Then the sides of the triangles are measured. The purpose of this process of working is to prevent accumulation of error. During the procedure, if there is any error in the measurement of any side of a triangle, then it will not affect the whole work. The error can always be detected and eliminated.

According to the second principle, the new stations should always be fixed by at least two measurements (linear or angular) from fixed reference points. Linear measurements refer to horizontal distances measured by chain or tape. Angular measurements refer to the magnetic bearing or horizontal angle taken by a prismatic compass or theodolite.

In chain surveying, the positions of main stations and directions of main survey lines are fixed by tie lines and check lines.

### **Chain Surveying:**

7. What is Chaining?
8. Instruments used in Chain Surveying?
9. How many links are in 30m Metric Chain? Length of each link?
10. Reciprocal Ranging?
11. What are Corrections?
12. How many ranging rods required for
  - a. Direct Ranging
  - b. Indirect or Reciprocal Ranging
13. Principle of Chain Surveying?
14. What is well-conditioned triangle?
15. What is Reconnaissance Survey?
16. What is Index Sketch?

17. How to set Perpendicular Offsets? (900)

18. What is Field Book?

### **Compass Surveying:**

19. Principle of Compass Surveying?

20. Explain:

a. True Meridian

b. Magnetic Meridian

c. Arbitrary Meridian

d. Magnetic Bearing

i. Whole Circle Bearing (WCB)

ii. Quadrantal Bearing (QB)

iii. Reduced Bearing (RB)

e. Fore Bearing

f. Back Bearing

g. Magnetic Declination

h. Dip of the magnetic needle

i. Local Attraction

20. What is traversing?

a. Close Traverse?

b. Open Traverse?

21. Check on Closed Traverse

a. Sum of exterior angles?

b. Sum of interior angles?

22. Check on Open Traverse

23. How to adjust Closing Error?

### **Plane Table Surveying:**

25. Principle of Plane Table Surveying?

26. Instruments used?

27. What is Orientation?

a. Orientation by Magnetic Needle?

b. Orientation by Backsighting?

28. Methods of Plane Tabling? What is the need of



- a. Radiation?
- b. Intersection?
- c. Traversing?
- d. Resection?

**Leveling:**

- 29. Uses of Leveling
- 30. Datum Surface or Line
- 31. Reduced Level?
- 32. Line of Collimation?
- 33. Bench-marks (BM)
  - a. GTS Bench-marks
  - b. Permanent Bench-marks
  - c. Arbitrary Bench-marks
  - d. Temporary Bench-marks
- 34. Backsight Reading (BS)
- 35. Foresight Reading (FS)
- 36. Intermediate sight Reading (IS)
- 37. Change Point?
- 38. Instruments used in Leveling?
- 39. Types of Leveling?
  - a. Simple Leveling
  - b. Differential Leveling
  - c. Fly Leveling?
  - d. Profile Leveling?
  - e. Check Leveling?
- 40. Need of Reciprocal Leveling?
- 41. Methods of Calculation of Reduced Level
  - a. Height of Instrumentation method
  - b. Rise-and-Fall method
- 42. Arithmetical Check?

**Contouring:**

- 43. What is Contour Map?

- 44. Contour Line?
- 45. Contour Interval?
- 46. Horizontal Equivalent?
- 47. Object of preparing Contour Map
- 48. Uses of Contour Map

**Computation of Area:**

- 49. Trapezoidal Rule?
- 50. Simpson's Rule? Limitation?

B.Tech. IV Semester  
**ADVANCED SURVEYING LAB (4CE4-24)**  
**Session 2022-23**

**Quiz**

1. What is Surveying?

- a) Surveying is used to find the elevations of given points with respect to given or assumed datum
- b) Surveying shows the relative positions of the objects on the surface of the earth
- c) Surveying is to find the elevation of points having the same contour interval
- d) All of the mentioned

**Answer:** (b)

2. Which of the following is the first principle of surveying?

- a) Whole to whole
- b) Part to part
- c) Part to whole
- d) Whole to part

**Answer:** (d)

3. Which of the following type of surveying is used for exploring mineral wealth?

- a) Military surveying
- b) Mine surveying
- c) Topographic surveying
- d) Engineering surveying

**Answer:** (b)

4. In which of the following type of surveying only linear measurements are made?

- a) Dumpy level
- b) Theodolite surveying
- c) Chain surveying
- d) Contouring

**Answer:** (c)

5. Which of the following classification in surveying is based on the instrument used?

- a) Traverse surveying
- b) Cadastral surveying
- c) Topographic surveying
- d) Hydrographic surveying

**Answer:** (a)

6. In which of the following areas does compass surveying is not recommended?

- a) Large areas
- b) Undulating areas
- c) Crowded with many details
- d) Local attraction suspected areas

**Answer:** (d)

7. In which of the following cases compass surveying is recommended?

- a) When area is small, undulating and not details are crowded
- b) When area is large, undulating and crowded with many details
- c) When area is small, even and crowded with many details
- d) When area is large, even and crowded with many details

**Answer:** (b)

8. Which of the following is not required for chain surveying?

- a) Dumpy level
- b) Pegs
- c) Arrows
- d) 20 m chain

**Answer:** (a)

9. Which of the following is the last step in chain surveying?

- a) Fixing
- b) Reconnaissance
- c) Running survey lines
- d) Marking

**Answer:** (c)

10. Which of the following cannot be done with the help of theodolite in surveying?

- a) Measuring horizontal distances
- b) Prolonging survey lines
- c) Laying off horizontal angles
- d) Locating points on lines

**Answer:** (a)

11. Which of the following is an indirect method of surveying?

- a) Countouring
- b) Chain surveying
- c) Tacheometry
- d) All of the mentioned

**Answer:** (c)

12. Which of the following branch of surveying is used to find the elevations of given points with respect to given or assumed datum?

- a) Plane table surveying
- b) Traversing
- c) Contouring
- d) Levelling

**Answer:** (d)

13. Which of the following is the principles of surveying?

- a) Covering the entire area
- b) Working from whole to part
- c) Taking measurements
- d) Determining the elevation differences

**Answer:** (b)

14. Which of the following surveying methods is meant to be having high precision?

- a) Terrestrial photogrammetry
- b) Traverse surveying
- c) Aerial photogrammetry
- d) Theodolite surveying

**Answer:** (c)

15. Which of the following doesn't describe the use of hydrographic surveying?

- a) Nautical charts for navigation
- b) Establishing mean sea level

- c) Laying an Alignment
- d) Making underground investigations

**Answer:** (b)

16. Which of the following type of ranging is done if both ends of surveying lines are visible?

- a) Indirect
- b) Reciprocal
- c) Unable to do
- d) Direct

**Answer:** (d)

17. Which of the following is not a method of levelling?

- a) Spirit levelling
- b) Traverse levelling
- c) Barometric levelling
- d) Trigonometric levelling

**Answer:** (b)

18. In which of the following type of surveying in the mean surface of the earth is considered as a plane and the spheroidal shape is neglected?

- a) Plane Surveying
- b) Geodetic Surveying
- c) Hydrographic Surveying
- d) Topographic Surveying

**Answer:** (a)

19. Which of the following doesn't involve the method of traversing?

- a) Plane Table surveying
- b) Tacheometric surveying
- c) Chain surveying
- d) Theodolite surveying

**Answer:** (b)

20. Which of the following is not a method of plane table surveying?

- a) Trisection
- b) Intersection
- c) Resection
- d) Radiation

**Answer:** (a)

21. While taking Observations for the height and distances, which of the following method of surveying is used?

- a) Plane surveying
- b) Geodic surveying
- c) Chain surveying
- d) Compass surveying

**Answer:** (b)

22. Which of the following type of surveying can be employed in a magnetic area?

- a) Compass surveying
- b) Traverse surveying
- c) Plane table surveying
- d) Theodolite surveying

**Answer:** (c)



23. Which of the following survey deals with bodies of water for the purpose of navigation, water supply, harbor works or for the determination of mean sea level?

- a) City surveying
- b) Cadastral surveying
- c) Topographic surveying
- d) Hydrographic surveying

**Answer:** (d)

24. Determining points of strategic importance are called \_\_\_\_\_

- a) Traverse surveying
- b) Military surveying
- c) City surveying
- d) Topographic surveying

**Answer:** (b)

25. Which of the following is not a natural error in compass surveying?

- a) Local attraction due to the proximity of local attraction forces
- b) Pivot being bent
- c) Magnetic changes in the atmosphere due to clouds and Strom's
- d) Variation in declination

**Answer:** (b)