

Analysis of Sustainable Building Materials, Their Possibilities and Challenges

A Major Project Report

Submitted to the Rajasthan Technical University

in partial fulfillment of requirements for the award of degree

Bachelor of Technology

in

Civil Engineering

by

Avinash Ahari

RTU ROLL NO.: 20ETCCE001



DEPARTMENT OF CIVIL ENGINEERING

TECHNO INDIA NJR INSTITUTE OF TECHNOLOGY

UDAIPUR, RAJASTHAN

Analysis of Sustainable Building Materials, Their Possibilities and Challenges

A Major Project Report

*Submitted to the Rajasthan Technical University
in partial fulfillment of requirements for the award of degree*

Bachelor of Technology

in

Civil Engineering

by

Avinash Ahari

RTU ROLL NO.: 20ETCCE001



**DEPARTMENT OF CIVIL ENGINEERING
TECHNO INDIA NJR INSTITUTE OF TECHNOLOGY
UDAIPUR, RAJASTHAN**

DEPARTMENT OF CIVIL ENGINEERING
TECHNO INDIA NJR INSTITUTE OF TECHNOLOGY UDAIPUR,
RAJASTHAN 2023 - 24



CERTIFICATE

This is to certify that the report entitled **Analysis of Sustainable Building Materials, Their Possibilities and challenges** submitted by Avinash Ahari (University Roll No.: 20ETCCE001), to Department of civil Engineering in partial fulfillment of the B.Tech. degree in **Civil Engineering** is a bonafide record of the seminar work carried out by him under our guidance and supervision. This report in any form has not been submitted to any other University or Institute for any purpose.

Project Guide Name

Mr. Nishit Jain
Assistant Professor
Department of Civil Engineering
Techno India NJR Institute
of Technology
Udaipur, Rajasthan

Project Coordinator Name

Mr. Rakesh Yadav
Assistant Professor
Department of Civil Engineering
Techno India NJR Institute
of Technology
Udaipur, Rajasthan

Mr. Rakesh Yadav
Assistant Professor and Coordinate
Department of Civil Engineering
Techno India NJR Institute of Technology
Udaipur, Rajasthan

DECLARATION

I Avinash Ahari hereby declare that the major project report on **Analysis of sustainable building materials, their possibilities and challenges**, submitted for partial fulfillment of the requirements for the award of degree of Bachelor of Technology of the Rajasthan Technical University, Kota, Rajasthan is a bonafide work done by me under supervision of Mr. Nishit Jain.

This submission represents my ideas in my own words and where ideas or words of others have been included, I have adequately and accurately cited and referenced the original sources.

I also declare that I have adhered to ethics of academic honesty and integrity and have not misrepresented or fabricated any data or idea or fact or source in my submission. I understand that any violation of the above will be cause for disciplinary action by the institute and/or the University and can also evoke penal action from the sources which have thus not been properly cited or from whom proper permission has not been obtained. This report has not been previously formed the basis for the award of any degree, diploma, or similar title of any other University.



Avinash Ahari

10/05/2024

Abstract

Sweden has as the first welfare state signed the petition of having net zero GHG emissions 2045. The construction industry is a large contributor to Sweden's current GHG emissions and an action plan signed by several construction companies, including Veidekke, has stated several partial goals and one end goal of a construction industry with net zero emissions 2045. At the same time the demand of new residential houses is high. The choice of material affects the GHG emissions during the entire lifetime, making it a key parameter when planning a construction. 80 % of the emissions during a construction origin from the production of the materials used. The R&D intensity in the construction industry is low and the sector is ruled by a high level of competition and low margins.

This thesis aimed to investigate more sustainable building materials for bearing parts of multifamily houses, how they compare with conventional materials and challenges facing them. The materials investigated was compared to a reference wall with KPI:s from one construction made by Veidekke. The GHG emission from the reference wall was calculated to be 107 kg CO₂-eq/m²_{wall}. The materials were evaluated with the method of Industrial Dynamics to investigate salient and reverse salient properties, lock-ins and important stakeholders. The materials investigated were Cross-laminated timber (CLT) and different types of sustainable concretes. Creating timber concrete hybrids were also explored. CLT currently has a small market share but is a promising material with several beneficial properties. The current development of more sustainable concrete resulted in the investigation of Recycled Aggregates Concrete, Alkali Activated Concrete and the Eco-concrete with reduced amount of cement in favor for limestone powder. A second step was to explore the social and economic challenges for integrating new building materials into the construction industry. As the industry is heavily project based, the timeframe and lack of budget to explore new options acts as barrier. The processes also tend to be repetitive. As of now the industry has made itself path dependent to concrete in a large extent. However, the social acceptance towards CLT is rising and making sustainability a strategic business goal is becoming more important to appeal to the customers. Interviews at Veidekke showed the rising interest of mixing timber and concrete, but also the difficulties of pushing development forward in the industry.

The materials and their KPI:s resulted in the further investigation of CLT and Eco-concrete. By stating the salient and reverse salient properties of the materials further analysis could be done. CLT showed the greatest reduction of GHG emissions due to the embodied carbon resulting in a negative GHG emission of -66.2 kg CO₂-eq/m²_{wall}. In addition to this the construction time and several other beneficial properties were found. The reduction of GHG emissions of the Eco-concrete is great too, about 50 % comparing with the concrete used in the reference wall. As a concrete the Eco-concrete should also face less barriers as the industry is familiar with the product. Further analysis with tools from industrial dynamics showed the importance of creating incitements for developing the knowledge of a sustainable construction industry. Results also showed that new networks between the manufactures and the building sector is of essence to find and use new materials. Timber and concrete

industries have the main responsibility of developing new and more sustainable products. The building sector also have a responsibility of choosing sustainable options.

The key stakeholders identified from stakeholder mapping was the business developers, the department of purchase, the timber and concrete industry and lastly the customers. Business developers need to pursue projects with clear and tough goals of sustainability. This will increase the chance of succeeding. The department of purchase need to have incitements for mapping sustainable materials and the ability to explore new subcontractors. The results of the analysis show that not a single innovation will solve the goal of having a construction industry with net zero emissions 2045.b

Acknowledgement

I take this opportunity to express my deepest sense of gratitude and sincere thanks to everyone who helped me to complete this work successfully. I express my sincere thanks to **Mr. Rakesh Yadav**, Head of Department, Civil Engineering, Techno India NJR Institute of Technology Udaipur for providing me with all the necessary facilities and support.

I would like to express my sincere gratitude to **Mr. Rakesh Yadav**, department of Civil Engineering, Techno India NJR Institute of Technology, Udaipur for their support and co-operation.

I would like to place on record my sincere gratitude to my project guide **Mr. Nishit Jain**, Assistant Professor, Civil Engineering, Techno India NJR Institute of Technology for the guidance and mentorship through out the course.

Finally, I thank my family, and friends who contributed to the successful fulfilment of this project work.



Avinash Ahari

Table of Contents

Chapter 1. Introduction.....	- 1 -
Chapter 2. Aim and objectives.....	- 4 -
2.1 Limitations	- 4 -
Chapter 3. Methodology	- 4 -
3.1 Sustainability assessment.....	- 6 -
3.2 Industrial dynamics	- 7 -
3.3 Interview technique.....	- 7 -
3.4 Key performance indicators	- 8 -
Chapter 4. State-of-the-Art building materials	- 9 -
4.1 Building materials used today	- 9 -
4.2 Cross-Laminated Timber (CLT).....	- 12 -
4.3 Sustainable concrete.....	- 17 -
4.3.1 Recycled aggregate concrete (RAC).....	- 18 -
4.3.3 Alkali-activated concrete (AA concrete).....	- 21 -
4.3.4 Eco-concrete with reduced cement content	- 24 -
4.4 Timber concrete hybrids.....	- 27 -
Concluding remark.....	- 30 -
Chapter 5. Social and Economic challenges.....	- 31 -
5.1 Project level.....	- 31 -
5.2 Sector level.....	- 32 -
5.3 Contextual level	- 34 -
5.4 Social and Economic challenges at Veidekke	- 35 -
5.4.1 Linda Björklund, Construction Site Manager, Veidekke Bygg Bostäder	- 35 -
5.4.2 Sofia Dehre, Director of Production Development, Veidekke Bygg Bostäder...	- 36 -
5.4.3 Lina Brantemark, Business Development, Veidekke Bostad.....	- 37 -
5.4.4 David Grimheden, Department Manager Timber Buildings, Veidekke Bygg Bostäder	- 38 -
Concluding remark.....	- 39 -
Chapter 6. Stakeholder and market mapping.....	- 39 -
6.1 Stakeholders	- 39 -
6.2 Push phenomenon	- 40 -
6.3 Pull phenomenon.....	- 41 -
Concluding remarks	- 42 -
Chapter 7. Results and discussion	- 43 -
7.1 System analysis	- 43 -
7.1.1 System analysis of CLT	- 44 -

7.1.2 System analysis of Eco-concrete	- 46 -
7.1.3 The S-curve of innovation adoption	- 48 -
7.2 Innovation 3D approach.....	- 49 -
7.2.1 Direction	- 49 -
7.2.2 Distribution	- 50 -
7.2.3 Diversity.....	- 50 -
7.3 Critical stakeholders.....	- 51 -
7.3.1 Manage closely	- 52 -
7.3.2 Keep satisfied.....	- 52 -
7.3.3 Keep informed	- 53 -
7.3.4 Monitor	- 53 -
7.4 Key innovation opportunities.....	- 54 -
Chapter 8. Conclusion and future work	- 56 -
8.1 Future work	- 57 -
Chapter 9. References	- 58 -
Appendix I.....	- 59 -
Reference wall	- 59 -
CLT wall	- 61 -
Recycled aggregate concrete (RAC).....	- 62 -
Alkali-Activated concrete (AA concrete)	- 62 -
Eco-concrete	- 62 -

List of Figures

Figure 1. The waste hierarchy.....	2
Figure 2. The process of this report.....	5
Figure 3. The three pillars of sustainability.....	6
Figure 4. Properties of the construction stage in a Life Cycle Analysis.....	6
Figure 5. Sandwich wall used as external wall in the project Branddörren and the dimensions of it.....	9
Figure 6. The structure of CLT.....	11
Figure 7. Cross section of an external wall using CLT board as bearing element.....	14
Figure 8. Lowering the amount of cement by adding superplasticizers.....	21
Figure 9. The concrete cores together with the CLT construction used in Brock Commons..	23
Figure 10. Construction of a TCC beam with the different connections.....	24
Figure 11. The investigated materials plotted depending on cost and CO ₂ emission per square meter wall.....	36
Figure 12. Salient and reverse salient properties of CLT.....	37
Figure 13. Salient and reverse salient properties of Eco-concrete.....	39
Figure 14. The S-curve of innovation adoption and the positioning of CLT and concrete.....	40
Figure 15. The stakeholders of integrating more sustainable building materials into the building sector.	43
Figure 16. Concrete wall element.....	

List of Tables

Table 1. End and partial goals for the construction industry stated by Fossilfritt Sverige.....	1
Table 2. Key performance indicators being investigated for new building materials.....	8
Table 3. Concrete mixture of the concrete for the sandwich walls in Branddörren.....	10
Table 4. Properties of the reference wall used in Branddörren.....	11
Table 5. Properties of a CLT wall.....	14
Table 6. Concrete mixture used to produce RAC.....	17
Table 7. Properties for Recycled Aggregate Concrete (RAC).....	17
Table 8. Concrete mixture of AA concrete using FA as binder compared to a comparing concrete using cement	18
Table 9. Properties of AA concrete.....	19
Table 10. Concrete mixture of Eco-concrete comparing with a reference concrete.....	21
Table 11. Properties of Eco-concrete.....	22
Table 12. Thermal conductivity of elements.....	i
Table 13. Volume of elements in reference wall using concrete.....	ii
Table 14. CO ₂ emission of each substance.....	ii
Table 15. Volume of each element in the CLT wall.....	iii
Table 16. CO ₂ emission for each element in the CLT wall.....	iii
Table 17. CO ₂ emission of each substance.....	iii
Table 18. CO ₂ emission of each element to produce reference wall in AA concrete.....	iii
Table 19. CO ₂ emission of each substance used in the Eco-concrete wall.....	iv

Chapter-1

1. Introduction

As the first welfare country in the world, Sweden has signed the petition of having net zero emissions of greenhouse gases (GHG) 2045. The government have planned the largest investments in history regarding environmental issues and are convinced that economic growth can be combined with lower GHG emissions (Regeringskansliet, 2018). The construction industry is a large part of Sweden's current GHG emissions. Excluding heating, the construction industry annually has emissions of 15 million tonnes CO₂-eq (Fossilfritt Sverige, 2018). This is equivalent to the annual emissions from the domestic transport in Sweden. An action plan, signed by several constructing companies, including Veidekke, have stated several partial goals until the end goal of a construction industry with net zero emissions 2045. These goals are presented in Table 1 below. One of these partial goals is to be completed already in 2022, making it crucial to start working immediately (Fossilfritt Sverige, 2018).

Table 1. End and partial goals for the construction industry stated by Fossilfritt Sverige (Fossilfritt Sverige, 2018)

2045	Net zero of GHG emissions
2040	75 % reduced GHG emissions (compared with 2015)
2030	50 % reduced GHG emissions (compared with 2015)
2020-2022	All operators in the construction industry have investigated their emissions and found their own climate goals.

To reach these goals, the industry is convinced that collaboration between all operators in the value chain is off essence. The industry could drop the emissions of nearly 50% until 2030 with already existing technology. However, new technology is required to reach the net zero goal (Fossilfritt Sverige, 2018). Introducing a sustainable perspective to all parts of the value chain, from planning, construction, operation and maintenance is key to realize the goals (World Green Building Council, 2018). Simultaneously is the demand of new residential houses high. Calculations shows that 600 000 new residences need to be built between 2017-2025 to meet the demand in Sweden (Fossilfritt Sverige, 2018).

The choice of building envelope and materials affects the GHG emissions of the building during its entire lifetime. Depending on different materials the energy demand and emissions for a building changes, making it a key parameter when designing a house (UN Environment, 2018). Building materials contributes to GHG emissions in its entire life cycle, starting with the extraction and manufacturing phase to the transportation, construction, use and demolition phases (Global Alliance for Buildings and Construction, 2016). The production of concrete and steel is currently a large contributor to the GHG emissions of the construction industry. As of today, 80% of the emissions during the construction time for a building, origins from the production of the materials being used (Fossilfritt Sverige, 2018). The materials with the highest CO₂ footprint are the ones used in external walls, upper floor constructions and

ceilings, contributing to 84.2 % of the total CO₂ emissions of a building. The materials used in these elements are typically concrete as they function as the bearing part of the building. To reach a construction industry with lower GHG emissions the requirement of new building materials with lower environmental effects are essential (Chau, Hui, Ng, & Powell, 2018).

Parallel to this, the functionality and performance of the materials cannot be compromised. New materials face tough regulations and have high requirements on mechanical properties and durability, while having a competitive price. Decreased emissions during the construction time of a building should not lead to higher emissions during another part of the lifetime, for example having a larger energy demand during the operational lifetime due to lower insulation value. Transportation of the materials is also a considerable part of the total emissions for the materials, around 20%, making it an important part of innovation too (Fossilfritt Sverige, 2018).

The construction industry annually produces a third of the total amount of waste in Sweden, making it a large potential for innovation (Fossilfritt Sverige, 2018). The waste mainly consists of soil created during construction and mineral waste in form of cement, brick and plaster. In 2016 the construction industry in Sweden produced 10.4 million tonnes of waste. 4.5 million tonnes was recycled as construction material and 1.1 million tonnes were recycled as energy. This implies that 55% of the waste produced was recycled. At the same time was 30% of the total waste left to disposal (Naturvårdsverket, 2018). Introducing the hierarchy of waste, as seen in Figure 1 below, clearly shows that the construction industry is far behind based on how waste is handled. The most desired way of managing waste is preventing and minimizing it. As a third step it should be reused (IVL Svenska Miljöinstitutet, 2018). As of today, the industry works primarily with the last three parts of the hierarchy; recycling, energy recovery and disposal. This leaves room for large improvements and shows that the industry should work with minimizing waste during the entire value chain, from designing to demolition (Naturvårdsverket, 2018).

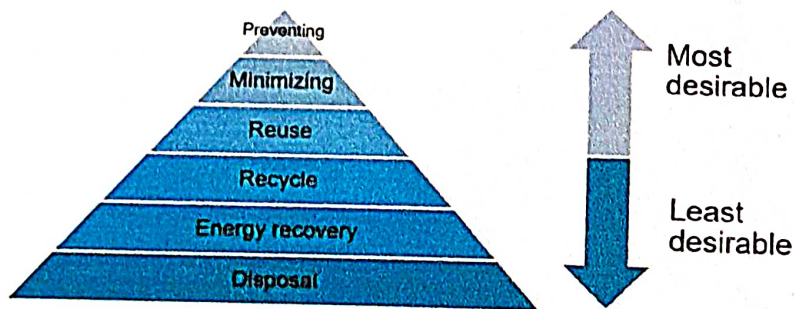

Figure 1. The waste hierarchy (IVL Svenska Miljöinstitutet, 2018)

A large potential for decreasing the GHG emissions in the industry is to investigate the opportunities of integrating the three top parts of the waste hierarchy, i.e. prevention, minimization and reuse. Further integrating the part of recycling is of essence too. Both reuse and recycling open possibilities for using circular flows of materials (Fossilfritt Sverige, 2018). Turning towards a circular economy is of high importance to reach a sustainable environment and economy. Creating a circular flow of building materials should be a part of this development (Hedman, 2018).

In addition, the construction industry has a comparatively low rate of research and development (R&D). In the EU R&D Scoreboard 2017 the sector of construction and materials is classified as a sector of low R&D intensity (EU, 2017). The sector has a high level of competition and low margins, opening few opportunities for innovation and new solutions being tested. Lowest price is still the largest source of competition in the industry, making it next to impossible to integrate innovation that requires large investments. The sector is also often described as conservative and known for having a large momentum, partly due to the high number of actors in the complicated value chain of the industry (Rosengren, 2018). Actors within the chain also feel a sense of awaiting. Both the contractors, clients and suppliers wait for one another to present, choose and wanting sustainable materials. Large actors in the industry are often the ones with the largest resources for investing in new technology. Parallel to this is the momentum of these actors larger compared with smaller businesses. At the same time doesn't smaller actors have the same assets for new technology, making it difficult to integrate innovation (Fossilfritt Sverige, 2018).

To reach the goal of having a construction industry with net zero emissions 2045 it's crucial to initiate the work towards sustainability. As previously stated, the building materials used today is the main contributor to the GHG emission of new constructions. Therefore, it's of essence to investigate new building materials, their properties and possibilities to be integrated into the building sector.

Chapter-2

2. Aim and objectives

The aim of this thesis is to investigate more sustainable building materials for constructing multifamily houses that decreases the GHG emissions during the construction phase. Comparing the materials found to a conventional material in a building today opens possibilities to see what different values they bring. By investigating the properties, energy efficiency, cost, lifetime, fire safety, sound insulation, added values etc. conclusions could be drawn to which materials that add the most value to a building. Analyzing the construction industry will enable the identification of which parameters and added values that's needed for a new material to become an attractive solution that still is profitable.

The key research questions being answered in this report is:

- Which new building materials could enable Sweden to fulfill the goal of net zero emissions 2045?
- How does the properties of the new materials compare to conventional materials?
- Which properties and added values are needed for the new materials to make them a competitive option to conventional materials?
- What are the challenges integrating new materials to the construction industry?

The expected impact of this study is to investigate sustainable building materials to fulfill the net zero goals of 2045. As the study focus on the two initial stages of innovation; search and strategic choice, the expected impact could be:

- Key opportunities for new sustainable building materials
- Innovation opportunities for new sustainable building materials
- Properties and added values needed for new materials to make them a competitive option to conventional building materials

2.1 Limitations

This study is limited to materials used in external walls and other bearing parts for multifamily houses. Conventional materials are referred to the materials being used in the reference case of this report. The technology of Carbon Capture and Storage (CCS) emerging technology for capturing the CO₂ emissions from different types of combustion processes. Some researchers believe it's a possible technology for lowering the CO₂-heavy industry of producing cement. However, the technology isn't in the scope of this project as it's not a construction material. CCS is only partially discussed, analyzed and compared with the materials found in this research in the section of discussion and further work.

Chapter 3

3. Methodology

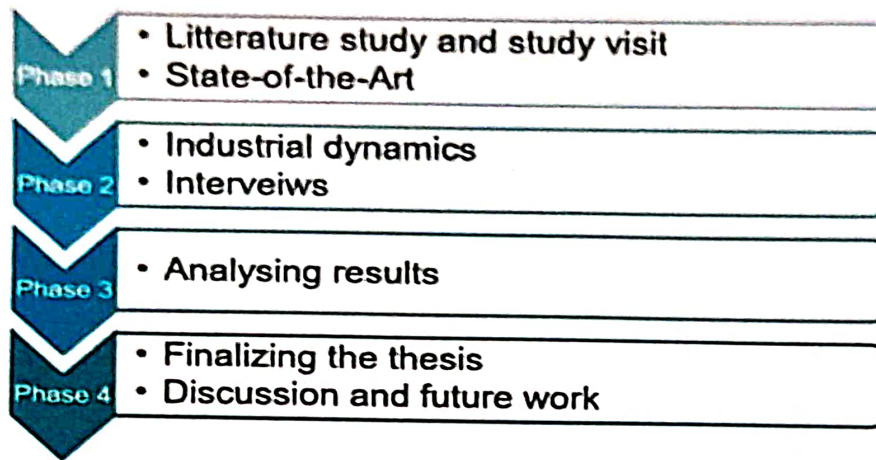

Figure 2. The process of this thesis

Phase 1

As an introduction to the thesis a literature study of the current situation was conducted. This part included which materials that are being used today, which properties these materials have and why using them in the future isn't sustainable. The second step was then to conduct a State-of-the-Art of new building materials. By mapping out the properties of costs, energy efficiency, added values etc. for the new materials further analysis could be done. This also gave indications to current problems and deepened the knowledge on obstacles that have been facing case studies so far.

Phase 2

By interviewing people working at different positions at Veidekke a deeper understanding of how the work of sustainability is perceived and executed at the company was identified. By further analyzing the construction industry with industrial dynamics deeper knowledge on how path dependencies, lock-ins, barriers of growth etc. in the sector affects the integration of new materials was developed.

Phase 3

By analyzing the results from the State-of-the-Art with industrial dynamics and innovation tools, critical problems with the found materials could be identified. This made it possible to transform these problems into innovation opportunities.

Phase 4

The conclusion of the thesis then states the different materials, their properties and added values to a building. By comparing them against each other, conclusions were drawn, and the pros and cons for the different materials could be presented. Further work and a discussion about the results will also be conducted.

3.1 Sustainability assessment

In this report the assessment of sustainability is based on the three pillars of sustainability: social, economic and environment, seen in Figure 3 below. These are the three properties one must consider and analyze when evaluating a system to make sure its sustainable. The environmental effects of building materials, the economic viability of them and the social factors as acceptance are some of the properties that will be evaluated.

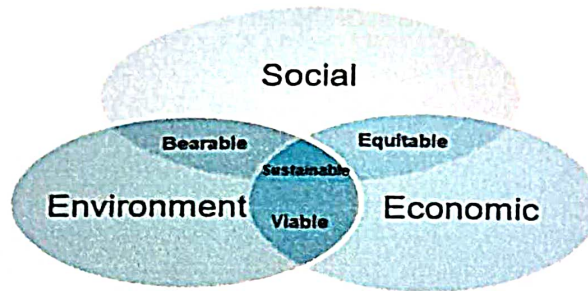

Figure 3. The three pillars of sustainability (University of Nottingham, 2018)

When studying building materials and their environmental affect, Life Cycle Analysis (LCA) is often conducted. This method makes it possible to investigate the total environmental effect of a building during its entire lifetime, from producing the materials, transporting them to the construction site, constructing the building, the emissions during the operational time and lastly the emissions for demolition. Using this method creates a general picture of the effects and makes it easier to make better and more environmentally friendly choices. Concerning this report and building materials, most of the emissions and impact of them refers to the parts of constructing a building, illustrated in Figure 4 below. Therefore, materials will be investigated mainly on the stages from raw material to manufacturing the building material, to delivering it to the site and finally having it assembled. In a traditional LCA the stages of operation and demolition is included too.

Construction process				
A 1-3 Production stage			A 4-5 Construction stage	
A1	A2	A3	A4	A5
Raw	Transport	Manufacturing	Transport	Construction
materials	to site	of building	to site	of building

Figure 4. Properties of the construction stage in a Life Cycle Analysis (Liljenström, o.a., 2015)

3.2 Industrial dynamics

By using methodology from industrial dynamics, the construction industry could be perceived as a sociotechnical system, meaning that the sector is made of different types of technologies, actors and institutions all rooted in our society. To compare and evaluate the different materials being presented in the

State-of-the-Art, tools from industrial dynamics will be applied (Anund Vogel, Lundqvist, & Arias, Categorizing barriers to energy efficiency in buildings, 2015). Using these tools enables identification of barriers of growth for each material, developing a framework for innovation opportunities. Salient and reverse salient properties of each material will be analyzed and presented, illustrating the level of maturity and suitability of the different materials. A component of the material lying ahead of the technology is referred as a salient and inverted when defining it as a reversed salient, i.e. a component that's restrains the integration of the material. However, the reverse salient of a material could enable innovation opportunities. The salient properties form the transformation pressure and enables the integration of the materials. Industrial dynamics will also analyze the path dependencies and lock-ins existing in the construction industry, presenting the current barriers of growth and how these could be transformed into innovation opportunities (Hughes, 1992). Analyzing the materials in a S-curve of innovation adoption will also determine the level of maturity and innovation phase the materials are placed in. This will simplify the understanding and possibilities of the materials (Kucharavy& De Guio, 2007).

Industrial dynamics will also be a part of the mapping of the stakeholders and the market. Stating the stakeholders affecting the integration of new building materials in the construction industry together with a market mapping will enable an analysis of both the push and pull phenomenon in the sector. The stakeholder analysis will also present the critical stakeholders to manage closely for increasing the success of the integration (Blomkvist, 2017). The stakeholder analysis will be conducted by a diagram where the stakeholders are placed depending on their power and interest in the integration of sustainable building materials in the building sector. Based on the difference in power and interest different categories of stakeholders will be created and clarifies which stakeholders who are highly important for succeeding (Thompson, 2018).

Another tool from industrial dynamics is Innovation 3D Approach which analyzes the parameters of Direction, Distribution and Diversity. Analyzing these three different parameters for the investigated building materials will state actions needed for transforming these materials from innovations into actions. Altogether this methodology will present the key innovation opportunities for integrating building materials with lower GHG emissions into the construction industry (Blomkvist, 2017). This method makes it possible to develop the most promising pathways for innovation and aims to benefit more *diverse* and *distributed* forms of innovation in different *directions* (Leach, Sustainability, Development, Social Justice: Towards a New Politics of Innovation, 2012).

3.3 Interview technique

To investigate the specific barriers and the attitude towards integrating more sustainable building materials at Veidekke interviews will be conducted. The interviews will be personal interviews with key actors at Veidekke who in different processes comes across the question

of sustainability. The aim is to interview actors from different positions in the value chain to capture the work and perception of sustainability from their specific department (Valenzuela & Shrivastava, 2019). Interviews will be conducted in a semistructured manner to let the interviewees explain and investigate their own perspective of sustainability. This semi-structure of the interviews are based on having questions based on a known area but being open for additional questions during the interviews (Research Methodology, 2019). The additional questions will enable the area of interest to be captured the best way possible. The interviews will result in a qualitative analysis of the barriers and approach to sustainability at Veidekke (Sallnäs, 2019). The results of the interviews will be presented by highlighting the key subjects described by the interviewees to simplify the general apprehension of sustainability and the work surrounding it at Veidekke (Hedin, 2019).

3.4 Key performance indicators

The key performance indicators being investigated for new building materials is presented in Table 2 below. Some qualities will be compared objectively with values found from the literature study, however, some qualities will be compared more subjective. To enable a comparison between the different building materials a definition of the subjective qualities will be made. High fire safety is based on the regulations made by Swedish building council, Boverket, where new multifamily houses is recommended to keep its bearing capacity in 90 minutes. High sound insulation is based on the highest level of sound insulation defined by Boverket, where the sound transmission from a stairwell into an apartment have a maximum of 56 dB (Boverket, 2018). Low delivery time is based on domestic manufacturing near the construction site. A high delivery time is defined as transportation of materials from Europe or other parts of the world. Medium construction time is based on the reference case where prefabricate wall elements were delivered and assembled on site. No toxicity is based on no toxic substances being released during the construction and operational time. Low toxicity is based on having some toxic releases during production or construction but not during the operational time, for example toxic dust being released when constructing in concrete. This is the lowest requirement from Boverket. Considerable toxicity is defined as toxic releases during operational time too (Boverket, 2018). High social sustainability is based on the definition of having healthy and livable communities for this and future generations. Thus, a building material must be sustainable socially for a long-time span (ADEC Innovations, 2018). High economic sustainability is based on the definition of using assets in the businesses to create a functioning profitability over time (Business Dictionary, 2018). Low social and economic sustainability is based on making businesses viable today and forgetting the sustainability of future generations.

Table 2. Key performance indicators being investigated for the investigated building materials

CATEGORY	QUALITY	UNIT
TECHNICAL PROPERTY	U-value	W/m ² K
TECHNICAL PROPERTY	Fire safety	Low/medium/high
TECHNICAL PROPERTY	Damp proof	Low/medium/high
TECHNICAL PROPERTY	Sound insulation	Low/medium/high
TECHNICAL PROPERTY	Cost	€/m ³

Chapter-4

4. State-of-the-Art building materials

By conducting a State-of-the-Art, new and innovative building materials that decrease the GHG emissions are investigated. The materials are divided into several categories depending on origin. By investigating the key performance indicators, the suitability of the materials and the barriers of growth will be identified. To enable the comparison and analyzing the different materials found in this State of the Art a reference wall was defined. Therefore, the first part of this chapter introduces a reference building being built by Veidekke and the materials used in it.

4.1 Building materials used today

Veidekke, as many other construction companies, have a high and rising share of prefabricated elements in their constructions. Therefore, materials used in the project named Branddörren, in Högdalen south of Stockholm, is presented. In this project several parts of the building are prefabricated and delivered to the construction site. The project includes 8 buildings, three high-rise buildings with a maximum of 16 stories and five lower units who are three stories high. In addition to this a shared underground garage is built under the block. The idea of this project was to use a higher share of prefabricated elements in the buildings. This resulted in having the beams, flooring, external walls, internal walls and a bathroom module prefabricated and delivered to the construction site. The bathroom module includes a completed bathroom with finished interiors, plumbing and wiring. This module is then connected to the rest of the installations in the apartment. The foundations of the buildings were the only large elements using concrete not being prefabricated as they were casted on site (Björklund, 2018).

Concentrating the research to one building and a specific external wall led to investigating one of the highrise buildings further. Building named P2 is 13 stories high and the external walls were delivered to the construction site with a facade in concrete, insulation and an internal front of concrete, seen in Figure 5 below. The windows were assembled in the factory too, only requiring installation of the doors when the modules were put in place. These walls are called sandwich walls and by insulating the concrete with a thick layer of EPS insulation the wall creates a low U-value, suited for the Nordic climate (Björklund, 2018). Calculations made showed that the U-value of this wall is around $0.198 \text{ W/m}^2\text{K}$, which is close to the recommended value for new developments according to Swedish building laws, $0.120 \text{ W/m}^2\text{K}$. Building laws in Sweden are regulated by Boverket, an authority with high requirements for all types of buildings. Especially for private housing, the rules are tough to secure good living conditions for all citizens. Apart from rules regarding U-values, fire safety, sound levels, moisture levels, indoor air quality and lighting etc. are also regulated by Boverket. The U-value of a wall indicates the level of heat transported through the construction and as low values as possible are beneficial to having a low energy usage in a building (Boverket, 2018). The prefabricated external walls were produced of a concrete with a strength grade of C35/45, corresponding to a compressive strength of 45 MPa or more, and made to resist external strains from the surrounding environment during its lifetime (Björklund, 2018).

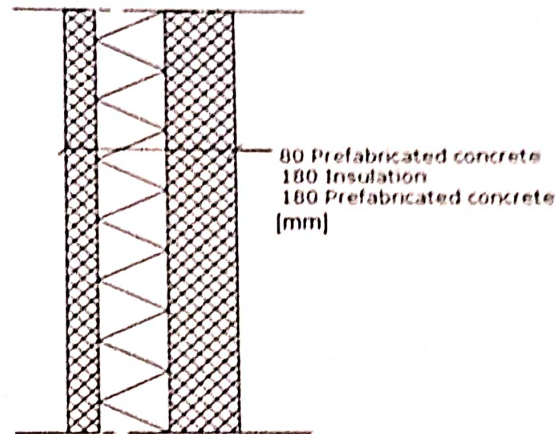

Figure 5. Sandwich wall used as external wall in the project Branddörren and the dimensions of it (Björklund, 2018)

Regarding the fire safety of the building, it follows the regulations from Boverket and guarantees that the walls hold their own weight for at least 90 minutes. This is a standard of fire safety when the risk of personal injury is very high (Svensk Betong, 2018). As beams and flooring are made of concrete too, the sound and vibration transmissions are low, an important property for multifamily houses and a favorable property when building in concrete. The high weight and stiffness of concrete are the main properties for the good sound and vibration qualities (Svensk Betong, 2018). Buildings could be classified depending on the level of sound insulation, where C is the least sound insulated option up to category A which is the maximum level of sound insulation. Category A have a maximum sound transmission from the hallway into an apartment of 56 dB according to Boverket. The sound level depends on several factors and could be reduced by simple design choices. Regarding damp there are regulations for the maximum content of moisture in a construction material. This is regulated

as heightened values of moisture could enabled microbial growth in the materials and threaten the quality of the living conditions (Boverket, 2018). The lifetime of the buildings of Branddörren is calculated to be 50 years, a common lifetime for new constructions. The beams being covered have a calculated lifetime of 100 years as inspections can't be made during the operational time (Björklund, 2018).

The total carbon emission from gravel to being installed in the construction site of the prefabricated concrete varies on several properties. The concrete mixture, transport distances between the different factories etc. affects the emissions. In the case of Branddörren, the manufacturer declared a CO₂ emission of 256 kg CO₂-eq/m³ concrete produced. The concrete mixture for producing the walls are presented in Table 3 below. However, the emission of the insulation, reinforcing steel and transportation of the completed elements to the construction site should be included. Including the emissions of the insulation and reinforcing steel results in 107 CO₂-eq/m²_{wall} produced. The calculations made for this number is presented in Appendix I (Dopierala, 2018).

Prefabricated concrete is produced in a factory, preferably close to the construction site and thereby contributing to low emissions from the transportation. However, in the case of Branddörren, the prefabricated concrete was produced in Posnań, Poland. The cost of the transportation contributed to 30 % of the total production cost of the elements (Björklund, 2018). The prefabricated slabs were transported approximately 1200 km, contributing to roughly 160 kg CO₂-eq/m³ concrete transported. In the case of the building P2, the transportation resulted in about 460 000 kg CO₂-eq being emitted only for the precast concrete to be delivered to the construction site (Omar, Doh, Panuwatwanich, & Miller, 2014). Including the transportation to the CO₂ emission of the wall element would result in an emission of 148.6 CO₂eq/m²_{wall}. In addition to this, the windows used in the buildings are produced in Vetlanda, southern Sweden. After being produced, the windows then need to be transported to Poznań, Poland, to be assembled onto the prefabricated elements. This ineffective supply chain contributes to even higher CO₂ emissions for the prefabricated concrete slabs (Björklund, 2018).

Table 3. Concrete mixture of the concrete for the sandwich walls in Branddörren (Dopierala, 2018)

	Unit	Reference concrete
Cement	kg/m ³	400
Aggregates	kg/m ³	1250
Sand	kg/m ³	600
Water	kg/m ³	125
Limestone	kg/m ³	50
Superplasticizer	kg/m ³	4.13

The price of producing the external walls are calculated to be 133.2 €/m²_{wall}, including all material and labor costs. The price includes the cost of assembling the windows onto the wall elements too. The transportation cost is excluded, however, if included, it contributes to an

additional 57.8 €/m²_{wall} (Björklund, 2018). During the production no recycling of raw materials are done, resulting in 0 % of recycling within the product. The producer estimates that 100 % of the concrete could be recycled after its operational lifetime, functioning as landfilling when crushing the concrete into gravel. A summarize of the properties for the reference wall are presented in Table 4 below.

Table 4. Properties of the reference wall used in Branddörren

QUALITY		UNIT	REFERENCE
U-VALUE	0.198	W/m ² K	(Björklund, 2018)
FIRE SAFETY	High		(Björklund, 2018)
DAMP PROOF	High		(Björklund, 2018)
SOUND INSULATION	High		(Björklund, 2018)
COST	511.9	€/m ³	(Björklund, 2018)
COST PRODUCING WALL ELEMENT	133.2	€/m ² wall	(Björklund, 2018)
LIFETIME	50	Years	(Björklund, 2018)
DELIVERY TIME	High		
CONSTRUCTION TIME	Medium		
TOXICITY	Low		
LEVEL OF RECYCLING (WITHIN PRODUCT)	0	%	(Dopierała, 2018)
POSSIBILITY OF RECYCLING (OF PRODUCT)	100	%	(Dopierała, 2018)
CO ₂ EMISSION (PRODUCTION)	256	kg CO ₂ -eq/m ³	(Dopierała, 2018)
CO ₂ EMISSION PRODUCING WALL ELEMENT	107	kg CO ₂ -eq/m ² wall	
SOCIAL SUSTAINABILITY	Low		
ECONOMIC SUSTAINABILITY	Medium		

4.2 Cross-Laminated Timber (CLT)

Using CLT as a construction material have an increasing popularity. The material is sustainable, have high durability and offers easy assembling. As of today, CLT replaces concrete, masonry and steel, i.e. substitutes the bearing parts of the construction. The material is assembled by at least three layers of wood panels being glued perpendicularly against each other under high pressure. This results in a material with high strength (Stora Enso, 2018). Currently its estimated that building multifamily houses up to 18 stories is possible with CLT, considering Mjøstårnet in Norway, and even higher if the construction is reinforced with a concrete foundation (Wählinder& Crocetti, 2018).

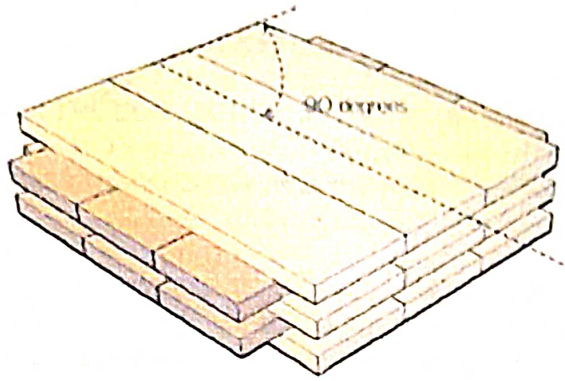

Figure 6. The structure of CLT (International Framers LLC, 2018)

The use of CLT is highly concentrated to Europe which holds 95% of the total market share. Austria has the largest market of CLT, 66% of the total percentage in Europe, mainly due to the technology origin from there. The market in Scandinavia is constantly rising as industries expands to meet the future demand (Brandner, Flatscher, Ringhofer, Schickhofer, & Thiel, 2016).

Regarding the properties of CLT as a construction material it has several advantages. CLT can be loaded both perpendicular and parallel to the surface (SvensktTrä, 2017). The exact lifetime of a building constructed in CLT is unknown as no building with the material have been in use for more than 40 years. However, there is existing timber houses who have been around for over 700 years and the aging of timer is researched and well known. Many suggest that constructions using CLT should have a comparable lifetime of a building in concrete. Current concrete framework and traditional timber structures have a calculated lifetime of 100 years, and as of today the only concern of the lifetime of CLT is the aging of the adhesive used between the layers of timber (Erlandsson, Larsson, Malmqvist, & Kellner, 2016). Looking into the building quality, prefabricated constructions often has higher building quality due to higher precision available in the controlled environment of a factory. The airtightness of the material is similar to a conventional building material resulting in a building with high energy efficiency, making it a desirable construction material (SvensktTrä, 2017). Considering the sound insulation of CLT there are both pros and cons. Sounds with low frequencies have a higher transmission through the material than conventional materials like concrete. The low density of CLT also contributes to this phenomenon as the lack of mass contributes to sound travelling through the material (Östman & Källsner, 2015). At the same time is sound travelled through timber considered more pleasant for people staying in the building comparing with sound travelled through concrete (SvensktTrä, 2018). Despite the disadvantages the sound transmission could be kept under the regulated values from Boverket using insulation (SvensktTrä, 2017).

The thermal conductivity of CLT is low which is a positive social aspect of the material as materials with low thermal conductivity is conceived as pleasant to touch. This contributes to houses built with CLT could have a lower indoor temperature, with several degrees, and still perform a pleasant indoor environment. Insulation is often necessary in the Nordic climate

and as CLT have good possibilities for storing heat, the indoor climate is easily evened out during the day. This storing of heat minimizes the requirement of ventilation as this heat, in a concrete construction, would have been ventilated out from the building to keep a constant indoor temperature (SvensktTrä, 2017). CLT alone has a low U-value of $0.87 \text{ W/m}^2\text{K}$ and the chosen external wall, shown in Figure 7 below, from the organization SvensktTrä, has a U-value of $0.15 \text{ W/m}^2\text{K}$. This performs better than the recommended value from Boverket and proves the good insulation properties of timber (SvensktTrä, 2017).

The adhesive used to produce CLT is currently based on polyurethane, which is non-toxic during its entire lifetime. This makes CLT a completely non-toxic material, suitable for residential houses who has increasing requirements on improved indoor air quality and advocate the usage of non-toxic building materials (Alinea, 2017).

The low weight and high bearing of CLT is two properties which has design advantages when constructing a building, making it more flexible to position doors and windows. The decreased weight requires reduced machinery, making the construction site quieter and more pleasant for the construction workers (SvensktTrä, 2017). Calculations shows that the construction time could be decreased by 10-30% with CLT, which is more economic profitable and preferred in dense urban areas (Wells, 2011). A building project called Strandparken, made by Folkhem, in Sundbyberg, Sweden, showed that a construction based entirely on timber and a bearing construction of CLT was built double as fast as a comparing building made of concrete (Zommodi, 2015). The storage of the material is a key parameter to retain the quality of CLT. During the construction time the material should be protected against moist on the construction site, otherwise the material might change dimensions and create cracks. Another characteristic of timber that must be considered is the orthotropic behavior, i.e. the different properties of the timber in the three different main directions. This is a characteristic of the material which should be considered when dimensioning and designing a building with CLT (SvensktTrä, 2017).

Considering the cost, building with CLT is found to be 10-20% (Wells, 2011) or 16-29% (Came, 2018) more expensive than a conventional reinforced concrete framework. Material and labor costs are lower than reinforced concrete but an increased insurance premium for building with CLT increases the total cost of production (Smyth, 2018). However, accounting for the time savings made when using CLT should be considered. Calculated production costs of a wall element in CLT, including material and labor costs, results in a price of $138.6 \text{ €/m}^2_{\text{wall}}$ (Sundberg & Åsberg, 2012). This could be compared with $133.2 \text{ €/m}^2_{\text{wall}}$ for the prefabricated wall elements used in the reference case. However, if the transportation cost of the reference wall is included in the calculations the price is $191 \text{ €/m}^2_{\text{wall}}$ (Björklund, 2018). At the same time is the market of CLT a fraction of the industry surrounding the conventional construction materials, making a growing market of CLT an opportunity of even lower material costs. As CLT currently is relatively cost competitive, this is a large potential for increasing market shares (BEST, 2017). The price of CLT as a raw material is highly depending on the dimensions of the products but an average price of $€500/\text{m}^3$ could be estimated in the European market. This higher price per cubic meter compared to conventional concrete is still viable as less material is used (CBI Ministry of Foreign Affairs,

2017). The domestic industry of timber products in Sweden is large and the forest resources have doubled the last 90 years (Skogsindustrierna, 2018). This opens possibilities for increasing the domestic manufacturing of CLT elements and the development of them. A common standardization of timber products similar to concrete is not developed. As of today, there are several certifications on timber products, but they only encounter for the sources of them, not the mechanical properties. This complicates the visualization of possibilities to the CLT as a construction material (Kellner, 2017).

Regarding fire safety, timber performs similar to concrete. Timber retains its structural form and produces a char layer which avoids contribution to the fire. The ignition of timber is slow, the penetration rate is about 0.6-1.1 mm/min and makes it possible to calculate how a fire will affect a building (SvensktTrä, 2017). In addition to this, a further resistance could be created by adding passive or active fire protection. A passive fire protection could be created by covering the CLT board with a protecting plasterboard and active protection is possible with a sprinkler system. Using mineral wool instead of EPS insulation could also create a further fire resistance. Referring to the project of Strandparken once again, this project includes three buildings of 8 stories each entirely made of timber. The fire safety follows the regulations made by Boverket as a sprinkler system has been installed in the buildings. By putting a sprinkler system in each apartment and the stairwells, the personal security against injuries is guaranteed. However, the protection of the property isn't guaranteed. This could make insurance companies unsure of how to price the insurance premium, and act as a barrier of using CLT in multifamily houses (Zommorodi, 2015).

Moisture is also an important factor for construction materials. Regarding CLT, depending on the moisture rate, it could both shrink and expand. As an organic material, timber has a natural process of transporting moisture, which improves the indoor air quality. Although, when used as a bearing part of the construction, the CLT boards are often covered up both externally and internally. An example of an external wall is shown in Figure 7 below. This external wall is an example of a bearing external wall that could be used for a multifamily house. The façade is made of panel boards which are attached to the veneer. The next part of the wall is the insulation layer, the vapor barrier and the 120 mm thick CLT board which acts as the bearing element of the wall. The CLT board is later covered with a plasterboard. The plasterboard is partly assembled onto the wall element to improve the fire safety (SvensktTrä, 2017).

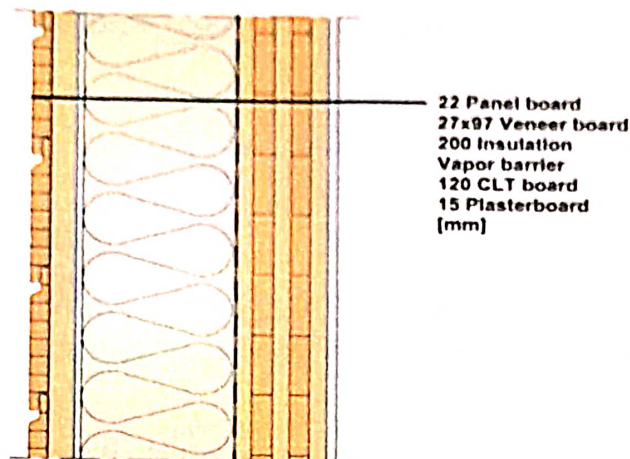

Figure 7. Cross section of an external wall using CLT board as bearing element (SvensktTrä, 2017).

Constructing buildings in CLT implies that the building could be considered as a net negative emitter due to the embodied CO₂ in the timber (SvensktTrä, 2017). Carbon savings using timber, instead of concrete and steel, is estimated to be 350 tonnes CO₂ per 1000 m² floor area being built. This carbon saving is equal to the emissions during 10 years of operation for the building (Alinea, 2017). Comparing a building using CLT to a building using reinforced concrete have shown that the energy consumption and carbon emission in an LCA-perspective is 9.9%-13.2% lower for a CLT building (Haibo, 2017). Only considering the production phase of CLT results in a negative GHG emission due to the embodied carbon in the timber. Its estimated that producing one cubic meter of CLT results in a negative CO₂ emission of -676kg (Building Constructing Design, 2015). To produce the wall element illustrated in Figure 7 calculations made in Appendix I showed that a negative emission of -66.2 kg CO₂-eq/m²_{wall} produced could be estimated.

A summary of the properties for CLT is compiled in Table 5 below.

Table 5. Properties of a CLT wall

QUALITY		UNIT	REFERENCE
U-VALUE	0.15	W/m ² K	(SvensktTrä, 2017)
FIRE SAFETY	High		(SvensktTrä, 2017)
DAMP PROOF	Medium		(SvensktTrä, 2017)
SOUND INSULATION	Medium		(SvensktTrä, 2017)
COST	500	€/m ³	(CBI Ministry of Foreign Affairs, 2017)

COST PRODUCING WALL ELEMENT	138.6	€/m ² wall	(Sundberg & Åsberg, 2012)
LIFETIME	100+	Years	(SvensktTrä, 2017)
DELIVERY TIME	Low		
CONSTRUCTION TIME	Low		
TOXICITY	Non		(Alinea, 2017)
LEVEL OF RECYCLING (WITHIN PRODUCT)	-	%	
POSSIBILITY OF RECYCLING (OF PRODUCT)	100	%	(SvensktTrä, 2017)
CO₂ FOOTPRINT (PRODUCTION)	-676	kg CO ₂ -eq/m ³	(Building Constructing Design, 2015)
CO₂ EMISSION PRODUCING WALL ELEMENT	-66.2	kg CO ₂ -eq/m ² wall	
SOCIAL SUSTAINABILITY	High		(SvensktTrä, 2017)
ECONOMIC SUSTAINABILITY	High		

4.3 Sustainable concrete

Concrete is the most popular construction material of today, mainly due to the great properties of the material. Robustness, long lifetime, low maintenance, high fire safety and solid against damp are some of the properties often described (Svensk Betong, 2018). Although isn't traditional concrete an option for a sustainable future as high GHG emission is connected to the production of the material.

Concrete primarily consists of three different materials; aggregates, cement and water. In addition to this are small amounts of additives added to improve the performance of the concrete. Aggregates build up the basic framework of concrete and cement act as the adhesive between the aggregate particles (Kiganda, 2017). Natural aggregates (NA) are typically a mixture of gravel from natural gravel pits and macadam produced from crushed rock material. Cement is produced by heating limestone to high temperatures and it's this process that's especially environmentally heavy. During the process large amounts of CO₂ is released, mostly from the limestone itself, but also from heating the oven with fossil fuels (Esping, 2017). The production of cement is constantly rising and is currently the third-largest source of CO₂ emission made by humans globally (Andrew, 2018). Even if cement only constitutes

to around 10 % of the concrete mix, it affects the properties of the concrete to a large extent and is the main cost of the mixture (Kiganda, 2017).

Although having several positive properties, there are some negative aspects connected to concrete too. During the lifetime of concrete, a natural process called carbonation occurs. This process is a result of the CO₂ in the air reacting with the calcium hydroxide in the concrete. This process produces calcite, i.e. a process where the concrete tries to return to its original form as limestone. The carbonation of concrete contributes to the corrosion of the reinforcing steel in the concrete and promotes a process of shrinkage of the concrete. However, the carbonation contributes to some positive changes too. The process increases the compressive and tensile strength of the concrete and contributes to a carbon reduction as CO₂ is collected from the surrounding atmosphere (WHD Microanalysis Consultants, 2018). The level of carbonation depends on the mixture of the concrete but is often estimated to 10% of the total CO₂ emission of the concrete during its entire lifetime (CPSA, 2011).

The largest challenge of the concrete industry is thus to develop and use new types of substitutes to conventional cement, using substitutional cementitious materials (SCM), to enable sustainable buildings in concrete. Securing sustainable sources of aggregates, recycling, integrating new technology and processes are also large challenges to decrease the GHG emissions and amount of waste produced. Sustainable sources of aggregates are needed due to the high volumes required, and especially as NA is a finite resource (Svensk Betong, 2017). Recycling concrete as aggregates, called recycled aggregates (RA), is a technology being introduced to the construction industry. Investigated in this section is the most developed technology surrounding recycled aggregate concrete (RAC). Recent research states that eco-friendly concrete could be achieved by using significantly lower amounts of cement and substituting it with SCMs. The same research also states that by using high-performance superplasticizers and lower water cement (w/c) ratio could be achieved, which is a positive property for lowering the GHG emission of the concrete. Using fly ash, limestone and alkali activated binders as SCMs are some of the most promising technologies that's presented in this section. In addition to this an initiative in Sweden called Betonginitiativet have been established. This initiative, including construction and concrete industries, researchers and authorities have a goal of reaching net zero emissions from the concrete industry using and developing similar technologies (Betonginitiativet, 2018).

4.3.1 Recycled aggregate concrete (RAC)

Using recycled construction and demolition waste (CDW) as aggregates have grown more popular recent years. The potential to reuse and recycle CDWs is high, especially as the waste has great resource value. Instead of landfilling with CDW, recycling it into roads, drainage and some structural constructions is possible (Pellegrino & Faleschini, 2016). At the same time, only 1% of the aggregates used worldwide in structural constructions are based on recycled concrete, implying large potential of growth (Tosic, Marinkovic, Dasic, & Stanic, 2015).

To produce recycled aggregates from CDW its processed through a recycling plant. The recycling has five main parts: separation, crushing, separation of ferrous elements, screening

and finally removal of impurities. This could be done either by a mobile or stationary plant. A mobile plant recycles the concrete on site and minimizes the transportation of the CDW. At the same time these plants have lower efficiency compared to stationary plants. Stationary ones produce a construction material with higher quality. During the process several steps of crushing the CDW its creased into the required grading. During the process steel, wood, paper, plastics etc. is removed, securing a clean product. Using recycled aggregates is especially suited for construction in dense urban areas, were the demand and supply is closely linked (Pellegrino &Faleschini, 2016).

In literature the use of recycled aggregates has shown good results, however the demand of natural aggregates is not disappearing as a total replacement to recycled aggregates have proven to be less feasible. This is mainly due to the lower quality based on the residue of cement in the recycled concrete aggregate. Instead a mixture of both natural aggregates and recycled concrete aggregates shown to be the most reasonable option (Tosic, Marinkovic, Dasic, & Stanic, 2015). For recycled aggregates to perform as a desirable construction material some basic requirements, especially concerning chemical stability and mechanical characteristics, must be met. The mechanical strength of concrete is mainly due to the ratio of water and the binder (cement), but also highly depend on quality, size and type of aggregates. Substituting new aggregates with recycled ones generally lower the mechanical strength, especially when the water-binder ratio is low. Replacing natural aggregates with recycled aggregates have shown a reduction of 20-25% in the compressive strength after 28 days of drying (Pellegrino &Faleschini, 2016). Comparing the compressive strength of concrete after 28 days is a standard used in the concrete industry. This is used as by 28 days conventional concrete has reached 99% of its strength (Mishra, 2018). The elastic modulus has proven to be reduced by 45% when replacing virgin aggregates with recycled ones. Lower density and higher absorption and porosity is also characteristics shown in RAC. These characteristics leads to a less durable concrete in terms of resistance to carbonization, permeation and freezing. This leads to an uncertain lifetime of RAC. To improve these reduced properties of the concrete an increased ratio of cement could be added, however would this procedure highly increase the cost and the GHG emission, missing the original cause of needing substitutes to conventional concrete (Pellegrino &Faleschini, 2016).

Testing RAC as a construction material have shown a larger bendability in beams compared to beams made of conventional concrete. The beams of RAC also experienced a higher rate of cracks and smaller crack spacing. These properties make the uncertainty of using RAC as a construction material even higher as the long-term performance of a building can't be guaranteed. However, according to some studies could high quality of the RAC minimize these characteristics and perform comparable to conventional concrete (Pellegrino &Faleschini, 2016). However, the properties of using it as a building material is estimated to have the same level of fire safety, sound insulation and U-value as conventional concrete.

A recent study investigated the optimal ratio of virgin and recycled aggregates, including the transportation needed during the process. An optimization regarding both economical, technical and environmental criterions showed that a concrete with an 50% ratio of recycled aggregate was the most preferable. This concrete mixture is presented in Table 6 below. The

GHG emissions of this concrete, 336 kg CO₂-eq/m³, is higher than the concrete used in the reference wall. Yet, several other sources have stated that conventional concrete could have an CO₂ emission of 400 kg CO₂-eq/m³, something that would make RAC preferable environmentally (Yang, Song, & Song, 2017). This increased GHG emission is due to higher amount of cement needed for the concrete to act as desired but also due to the process of making recycled concrete into aggregate. However, the production of the RAC produce less waste as smaller amounts of concrete is landfilled. The total level of recycling in the product is 33 % and 100 % of the product is expected to be recyclable in the end of its lifetime. This total recycling of the concrete is expected if the concrete is used as recycled aggregates once again. Considering price, RAC is 10 % more expensive than conventional concrete. Using the reference case of Branddörren results in a production cost of 563 €/m³ (Tosic, Marinkovic, Dasic, & Stanic, 2015). Another key parameter to the carbon footprint of RAC is the transportation of the recycled aggregate. To lower the emissions mobile recycling facilities on site is preferable (Xiao, Wang, Ding, & Akbarnezhad, 2018).

Table 6. Concrete mixture used to produce RAC (Tosic, Marinkovic, Dasic, & Stanic, 2015)

	Unit	Reference concrete	RAC
Cement	kg/m ³	354	354
Sand	kg/m ³	600	598
Natural aggregates	kg/m ³	1164	555
Recycled aggregates	kg/m ³	-	555
Water	kg/m ³	185	205
w/c	-	0.524	0.524

Calculations on the price of a wall element, with the same dimensions as the external walls of Branddörren illustrated in Figure 5, being produced in RAC is shown in Appendix I . The calculations resulted in a price of 146.5 €/m²_{wall}, including all material and labor costs. The CO₂ emissions of the wall element was calculated too and showed that 127.8 kg CO₂-eq/m²_{wall} is emitted. The summarized properties of RAC is presented in Table 7 below.

Table 7. Properties for Recycled Aggregate Concrete (RAC)

QUALITY		UNIT	REFERENCE
U-VALUE	0.198	W/m ² K	(Pellegrino & Faleschini, 2016)
FIRE SAFETY	High		
DAMP PROOF	High		
SOUND INSULATION	High		
COST	563	€/m ³	(Tosic, Marinkovic, Dasic, & Stanic, 2015)
COST PRODUCING WALL ELEMENT	146.5	€/m ² wall	

LIFETIME	50	Years	(Pellegrino & Faleschini, 2016)
DELIVERY TIME	Low		
CONSTRUCTION TIME	Medium		
TOXICITY	Low		
LEVEL OF RECYCLING (WITHIN PRODUCT)	33	%	(Tosic, Marinkovic, Dasic, & Stanic, 2015)
POSSIBILITY OF RECYCLING (OF PRODUCT)	100	%	(Tosic, Marinkovic, Dasic, & Stanic, 2015)
CO₂ EMISSION (PRODUCTION)	336	kg CO ₂ -eq/m ³	(Tosic, Marinkovic, Dasic, & Stanic, 2015)
CO₂ EMISSION PRODUCING WALL ELEMENT	127.8	kg CO ₂ -eq/m ² wall	
SOCIAL SUSTAINABILITY	Low		
ECONOMIC SUSTAINABILITY	Medium		

4.3.3 Alkali-activated concrete (AA concrete)

Since late 1990's the interest of using Alkali-activated (AA) binders in concrete have grown, especially as an effort to lower the CO₂ emission from the production of concrete. The AA binder generally origin from one or a mixture of the mineral binders fly ash (FA), ground granulated blast-furnace slag (GGBFS, comparable with EAF slag) and metakaolin (MK). FA and GGBFS are biproducts of industrial processes and are commonly used in concrete mixtures of today as a supplementary cementitious material. Using them as SCMs have been increasing since the introduction of them into the industry in the 1950's. To produce AA-binders the mineral binders are chemically activated by adding an alkaline activator solution, a solution based on different types of salts with alkali metal ions. The strongest property of this concrete is the recycling and non-calcination of byproducts, something that is perceived as a less CO₂ heavy compared to conventional concrete. However, actual data of the CO₂ emissions from AA concrete is very rare and calls for further investigations. In addition to this, the alkali ions used in the activator solution requires a treatment that in some aspects is similar to the calcination process. This results in the alkali activators to be relatively CO₂ heavy, consequently adding to the CO₂ emission of the concrete. When using some of the binders, higher curing temperatures are needed, a property also accounting for increased CO₂ emission. This verify that the type and concentration of alkali activator highly effects the reduction of CO₂ emission of an AA concrete, as well as the mineral binder being used. Some calculations have indicated that the alkali activator accounts for just over 30 % of the total carbon footprint (Yang, Song, & Song, 2017).

The concrete mixtures being compared in Table 8 below have the same compressive strength, 40 MPa, and are comparable with the concrete used in Branddörren, considering the properties of strength. The CO₂ emission of the AA concrete using fly ash as binder is calculated to be 181.2 kg CO₂/m³ comparing to 256 kg CO₂-eq/m³ of the conventional concrete used in the reference case. This would suggest a 30 % reduction of GHG emissions. Using GGBS as binder have shown ever greater reductions, having a CO₂ emission of 122 kg CO₂-eq/m³. The usage of cementitious materials in AA concrete is higher compared to conventional concrete and is amplified with higher compressive strengths. However, the CO₂ emission is still lower than for conventional concrete regardless of the high emissions connected to the production of the activators (Yang, Song, & Song, 2017).

Table 8. Concrete mixture of AA concrete using FA as binder compared to a comparing concrete using cement (Yang, Song, & Song, 2017)

	Unit	Reference concrete	AA concrete with FA
Cement	kg/m ³	C40 361	C40
Fly ash	kg/m ³	23	-
GGBS	kg/m ³	68	469
Alkali activator	kg/m ³	-	-
Sand 0-4mm	kg/m ³	805	75
Gravel 4-16mm	kg/m ³	918	623
Superplasticizer	kg/m ³	3.1	935
Water	kg/m ³	163	-
			112

Regardless of the positive reduction in CO₂ emissions, AA concrete still faces some problems, creating a barrier to diffuse the innovation into the construction industry. The main problems are poor workability, low resistance against caustic solutions and the efflorescence, i.e. a process where the alkali metal migrate to the surface of the concrete and creates a coating. The cost of AA concrete could also be considered as a barrier as it's slightly higher than for conventional concrete and only have a comparable price to conventional concrete if the strength class is very high (Pacheco-Torgal, Abdollahnejad, Miraldo, & Kheradmand, 2017). Some research indicates that producing AA concrete costs 85-140 % of producing comparable concrete using cement. This results in a mean value of 12.5 % higher production cost of AA concrete. This would result in a price of 575.9 €/m³ to produce wall elements using AA concrete, including labor and all material costs, and a price of 149.9 €/m² wall considering the reference wall used in Branddörren (Thomas, Ye, Radlińska, & Peethamparan, 2016). To reduce the price some researchers suggest the usage of activators with a waste-based origin or conducting research to find cheaper alternatives. Regarding the durability of the concrete, the degradation of AA concrete exposed to service conditions for more than 30 years is proven to be small. However, the research of the area is very limited and states that the problems with efflorescence and corrosion of steel should be considered. The problem of efflorescence could be reduced by adding admixtures with high content of alumina or by curing the concrete at an elevated temperature. The corrosion of the reinforcing steel is also a

concern limiting the application in the construction industry. The corrosion depends on the high rate of carbonation in the AA concrete. The carbonation process enables the corrosion and as the volume of the steel increases due to the formed corrosion layer, cracking in the concrete could occur. To solve this problem stainless steel or corrosion inhibitors could be used. However, these actions widely affect the cost of the material and acts as a barrier of growth too (Pacheco-Torgal, Abdollahnejad, Miraldo, & Kheradmand, 2017).

Producing the reference wall in AA concrete used in Branddörren results in 87.5 kg CO₂-eq/m² wall according to calculations made in Appendix I. According to Table 8, the level of recycling within the product is 21.2 % when considering fly ash as a recycled material. Many of the mechanical properties, i.e. U-value, lifetime, fire safety etc., is considered to be the same as for the conventional concrete used in Branddörren (Thomas, Ye, Radlińska, & Peethamparan, 2016).

Table 9. Properties of AA concrete

QUALITY		UNIT	REFERENCE
U-VALUE	0.198	W/m ² K	(Thomas, Ye, Radlińska, & Peethamparan, 2016)
FIRE SAFETY	High		
DAMP PROOF	High		
SOUND INSULATION	High		
COST	575.9	€/m ³	(Thomas, Ye, Radlińska, & Peethamparan, 2016)
COST PRODUCING WALL ELEMENT	149.9	€/m ² wall	(Thomas, Ye, Radlińska, & Peethamparan, 2016)
LIFETIME	50	Years	(Thomas, Ye, Radlińska, & Peethamparan, 2016)
DELIVERY TIME	High		
CONSTRUCTION TIME	Medium		
TOXICITY	Low		
LEVEL OF RECYCLING (WITHIN PRODUCT)	21.2	%	(Yang, Song, & Song, 2017)
POSSIBILITY OF RECYCLING (OF PRODUCT)	100	%	(Yang, Song, & Song, 2017)

CO₂ EMISSION (PRODUCTION)	181.3	kg CO ₂ -eq/m ³	(Yang, Song, & Song, 2017)
CO₂ EMISSION PRODUCING WALL ELEMENT	87.5	kg CO ₂ -eq/m ² wall	
SOCIAL SUSTAINABILITY	Low		
ECONOMICAL SUSTAINABILITY	Medium		

4.3.4 Eco-concrete with reduced cement content

The research of concrete, as described before, have two main strategies for achieving lower GHG emissions. The first type of research is replacing cement with large amounts of fly ash or slag, using conventional concrete technology. The other type of research concentrates on applying more efficient usage of cement and other reactive materials based on modified design approaches. Modified design approaches often concentrate on lowering the amount of cement used in a concrete mixture by favoring the usage of other reactive materials instead, materials called pozzolanic (Proske, Hainer, M, & Graubner, 2017).

Experimental results have showed some key steps for approaching a more sustainable concrete mixture. The first step of this is to choose a cement with high strength to enable the usage of substitutional cementitious materials (SCMs) like fly ash, granulated blast furnace slag (GBFS) and limestone. All three of these SCMs have lower GHG emissions than conventional cement. A second key step is to optimize the content of water and the cementitious materials in the mixture and lastly, in step three, optimize the volume of the concrete mixture. Choosing a high-performance cement often favors the conventional Portland cement or blast furnace cement. However, increasing the usage blast furnace slag and fly ash in concrete mixtures is often limited by regulations and regarding these materials as renewable and CO₂ neutral is under questioning. Reducing the content of water and cement is based on the idea that lowering the water content enables less cement being used. However, this action affects the workability of the concrete in a high extent and that's a property that can't be diminished. By adding superplasticizers with high-performance to the mixture the dispersion of the particles in the mixture increases and enables a higher packing density of them. This results in less water being required, and hence also less cement. This process is illustrated in Figure 8 below and creates a concrete being called Eco-concrete in this report. The corresponding volume saved by using less water and cement could be replaced with more environmentally friendly options, like powder based on limestone. Fly ash or slag could also be used. The powder contributes to the strength of the concrete and makes sure it still performs according to the regulations. Using powder of limestone is preferred as the availability is much larger than for the byproducts fly ash and slag. The emissions from limestone powder is lower too, especially if regarding the byproducts as nonrenewable (Proske, Hainer, M, & Graubner, 2017).

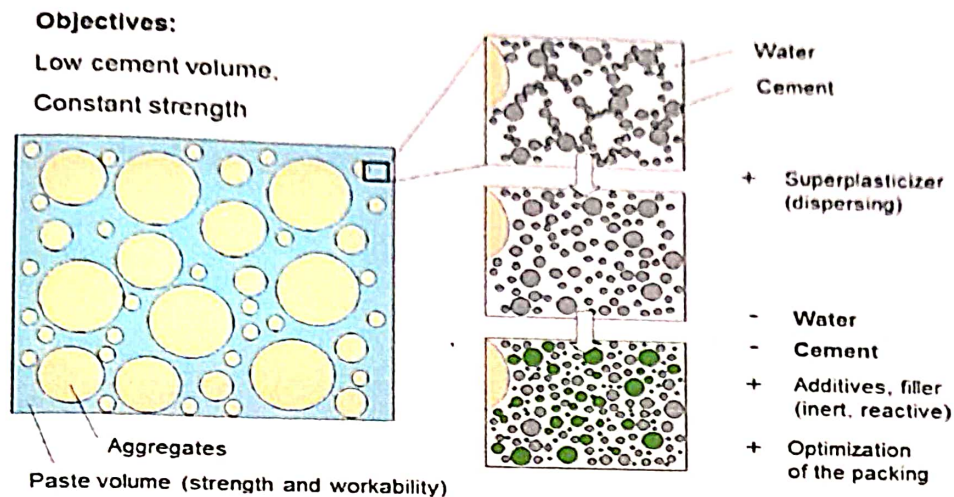

Figure 8. Lowering the amount of cement by adding superplasticizers (Proske, Hainer, M, & Graubner, 2017)

By conducting several experiments, the minimum volume of water was calculated to be 145 L/m³. Decreasing the water content further showed an insufficient workability. Experiments also showed a loss in the compressive strength due to the decreased cement content. This effect, however, could be minimized by using less water and by adding reactive additives as fly ash and slag to the mixture. Mixtures having a cement content of only 150 kg/m³ could still meet the requirements in strength of the concrete used in Branddörren. The reduction of cement is almost 50 %. To further increase the reduction of cement, and consequently the amount of water, the size of the granular powder of limestone, used in the mixture, should be optimized. By having a fine powder, the interface between the cement and aggregates is improved, increasing the workability of the mixture and contributing to less superplasticizer needed. The carbonation of the concrete when using additives like fly ash and limestone have shown to be reduced, acting as a positive property of the Eco-concrete (Proske, Hainer, M, & Graubner, 2017).

The CO₂ emission of the Eco-concrete, compared to a conventional concrete with the same compressive strength, is proven to be reduced by 35 % when using fly ash and limestone and by 60 % when using slag. The reduction is mainly due to the decreased amount of cement in the mixture. Referring to a mixture having the same exposure class as the concrete used in Branddörren, the mixture consists of 35 % less cement by adding fly ash and limestone powder. This concrete mixture could be seen in Table 10 below. The amount of cement in this mixture is below the regulated value. Referring to the exposure classes used for the reference wall in Branddörren, the minimum amount of cement is 270 kg/m³. The water cement ratio can't exceed 0.6, including all cementitious materials. Using this mixture thus requires that a building authority accepts it in advance. Yet, the compressive strength of the concrete mixture is higher than for the conventional. Shrinkage of the Eco-concrete is lower, which is considered as a positive property. The CO₂ emission of the Eco-concrete described in Table 10 below is reduced by 50 % comparing with the reference concrete, resulting in 150 kg CO₂-eq/m³ produced concrete. This calculation was based on reinforced prefabricated concrete

slabs used in practice. The costs of the Eco-friendly concrete are found to be similar or even lower than conventional concrete. The price is heavily dependent on the costs of the additives, especially the superplasticizers and limestone powder. However, in this report the price of the Eco-concrete is considered to be the same as the reference case Branddörren (Proske, Hainer, M, &Graubner, 2017).

Table 10. Concrete mixture of Eco-concrete comparing with a reference concrete (Proske, Hainer, M, &Graubner; 2017)

		Reference concrete	Eco-concrete
Strength class		C30/37	C30/37
Exposure class		XC4/XF1	XC4/XF1
Cement	kg/m ³	275	180
Fly ash	kg/m ³	30	90
Limestone powder	kg/m ³	-	119
Sand 0-4mm	kg/m ³	693	721
Gravel 4-16mm	kg/m ³	1183	1126
Superplasticizer	kg/m ³	4	4
Total water	kg/m ³	172	146
w/c	-	0.63	0.81

The CO₂ emissions producing the reference wall element in Eco-concrete, illustrated in Figure 5, results in 46.4 kg CO₂-eq/m²_{wall}. The calculations of this are presented in Appendix I. The properties of the Ecoconcrete are considered to be the same as the concrete used in the reference wall as they are produced to have the same strength class. Fly ash is the only substance in the concrete mixture considered as recycled, due to its origin as a byproduct from industrial processes. 100 % recycling should be possible if the concrete is used as recycled aggregates. A summarize of the properties of Eco-concrete is presented in Table 11 below.

Table 11. Summarized properties of the Eco-concrete

QUALITY		UNIT	REFERENCE
U-VALUE	0.1984	W/m ² K	(Proske, Hainer, M, &Graubner, 2017)
FIRE SAFETY	High		
DAMP PROOF	High		
SOUND INSULATION	High		
COST	511.9	€/m ³	(Proske, Hainer, M, &Graubner, 2017)
COST PRODUCING WALL ELEMENT	133.2	€/m ² wall	

LIFETIME	50	Years	(Proske, Hainer, M, &Graubner, 2017)
DELIVERY TIME	Low		
CONSTRUCTION TIME	Medium		
TOXICITY	Low		
LEVEL OF RECYCLING (WITHIN PRODUCT)	4	%	(Proske, Hainer, M, &Graubner, 2017)
POSSIBILITY OF RECYCLING (OF PRODUCT)	100	%	
CO₂ EMISSION (PRODUCTION)	150	kg CO ₂ -eq/m ³	(Proske, Hainer, M, &Graubner, 2017)
CO₂ EMISSION PRODUCING WALL ELEMENT	46.4	kg CO ₂ -eq/m ² wall	(Proske, Hainer, M, &Graubner, 2017)
SOCIAL SUSTAINABILITY	Medium		
ECONOMIC SUSTAINABILITY	Medium		

4.4 Timber concrete hybrids

By combining the different properties of timber and concrete unique characteristics could be created parallel to lowering the environmental impacts compared to conventional concrete. Creating hybrid solutions could enable the penetration of timber-based products into the construction industry, especially where concrete solutions are preferred. Stabilizing high timber buildings using a concrete core is one example of a hybrid solution with low environmental impact and utilization of the materials based on their best properties. Hybrid solutions could also help to establish the perception of viewing the solutions as complementary rather than competing (Wählinder & Crocetti, 2018). In this section recent projects and research based on timber concrete hybrids are presented.

By using concrete to construct the elevator shafts or the stairwells, the stiffness of the concrete acts as a beneficial property to the construction. This technology was adapted when constructing an 18 stories high building in CLT in Vancouver, Canada called Brock Commons, illustrated in Figure 9 below. The construction started with the casting of two concrete cores, containing the elevator shafts and stairwells. These two cores stabilized the building horizontally. After these two cores were established, columns and beams made of CLT was assembled onto them. By having the cores, this assembling was fast. In one week, two stories could be assembled. This is mainly due to no temporary stabilization of the construction was needed as the concrete cores stabilized the building sufficiently. By having

these cores, the columns of CLT is only vertically loaded, the direction were the properties of timber are most beneficial (Wählinder& Crocetti, 2018).

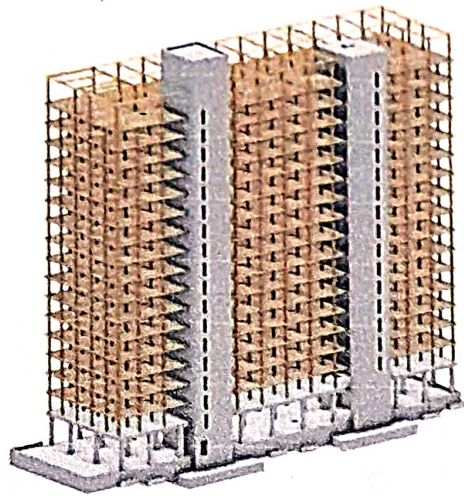

Figure 9. The concrete cores together with the CLT construction used in Brock Commons (Univeristy of British Colombia, 2016)

Some researchers suggest that creating hybrid materials based on timber and concrete, called TimberConcrete Composites (TCC), could be the solution to a sustainable construction industry. Rather than having a supporting framework of concrete as in Figure 9 this technology combines the two vastly different materials to create a material with unique mechanical properties. Consequently, the GHG emission of an element using TCC is lower than using a conventional element made of concrete (Thilén, 2017). The idea of combining different materials to achieve enhanced mechanical properties isn't new, reinforced concrete is an example of this. In reinforced concrete, steel is included in the concrete to improve the bearing capacity and increase the range of applications. As the development of new construction materials and systems often is made of the material manufactures themselves, and research conducted often is based on individual materials, investigating applications of hybrid solutions isn't made sufficiently (Wählinder& Crocetti, 2018).

As described earlier in the report, when producing wood, the GHG emissions are negative due to the embodied carbon in the timber. Another positive property of wood is the high mechanical strength under both pressure and drawing in the fiber direction. This makes the wood strong and stiff material compared to its weight. However, wood also have negative properties when applying it as a construction material. As it has an organic origin the mechanical properties differ for each case. In addition to this the low weight is a problem as the transmission of sound and vibrations are higher compared to concrete. When loading a beam, it starts to sway. Depending on the properties of the beam, the fluctuations differ. Low mass is one property increasing the fluctuations. Beams made of timber also have tendencies to yield, creating problems when it's used in multifamily houses. The low elastic modulus is also a concern. To compensate for these properties, incorporating concrete to create a hybrid material, have shown good results. Also described before is the positive properties of concrete regarding mechanical strength and transmission of sound and vibrations. By creating a

composite beam the properties of the two materials could collaborate. The high mechanical strength of wood in drawing, combined with the high compressive strength of concrete creates an attractive construction material. The composite beam has a highly increased bending stiffness compared to an equivalent wood beam. The increased weight of the wooden beams also prevents the risk of overturn, a risk associated when constructing a light and high building. An illustration of a composite beam developed by researchers at Lund's University is presented in Figure 10 below (Wählinder & Crocetti, 2018).

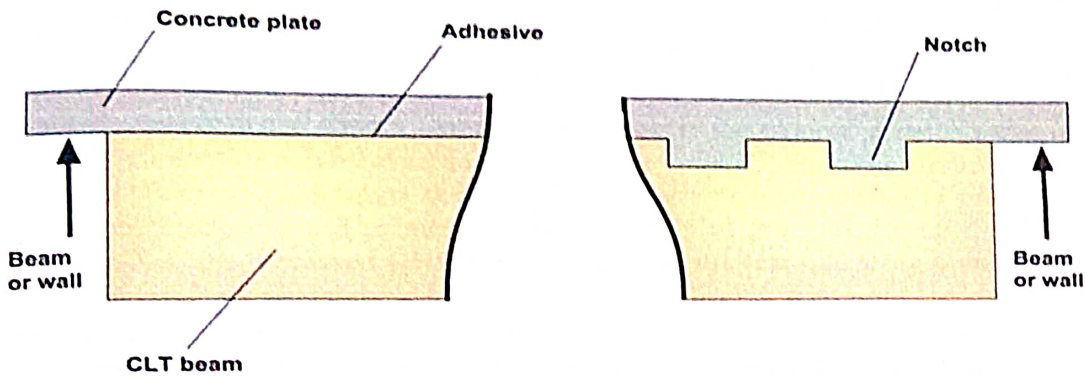

Figure 10. Construction of a TCC beam with the different connections (Wählinder & Crocetti, 2018)

Recent studies have proposed two different connections for creating the composite effect between the wood and the concrete. If the concrete isn't connected to the wood correctly, no or low effects of the composite is reached. Not achieving the maximum composite effect leads to an ineffective usage of the materials. The first connection is made of an adhesive added to the wooden parts before its covered with concrete. The concrete could either be a precast concrete board or wet concrete poured over the adhesive. The adhesive secures that the shear forces transfers through the connection correctly. The second type of connector is made of notches in the wood, creating cavities to improve the connection between the concrete and timber, ultimately generating a stronger composite. The research done on the two types of connections shows that the adhesive connection shows a higher stiffness. However, it also complicates the process if the concrete is casted on to the wet adhesive, as the time from applying the adhesive to covering it with concrete is limited. The notched connection shows lower stiffness but is appreciated for its simplicity and still deliver high composite effects. The properties of long-time loading are still to be conducted, but the research so far shows the high potential for using TCC in building constructions. The fire safety of multifamily houses built in CLT could be increased using the TCC technology as the layer of concrete would increase the resistance of fire (Thilén, 2017).

Regardless of using a supporting framework in concrete in a timber building or adding it to elements made in CLT to create a composite material, the possibilities of combining these to materials is promising. The combination of them could increase and simplify the integration of timber into the building sector.

Concluding remark

The materials investigated in this section was compared with a reference wall element used in Branddörren, a project made by Veidekke. The reference wall element is prefabricated and transported to the construction site. The GHG emissions of the concrete used is high and the long transportation of the completed elements from Poland to Sweden should be considered too. However, the properties of the concrete are good and fulfill the requirements of Boverket. Using CLT in multifamily houses is promising and the interest of the material is constantly rising. Many of the properties regarding CLT as a building material is positive and provides a better working environment. The construction time using CLT instead of concrete is shown to be decreased, in some cases by 50 %. Environmentally, using CLT have no competitor as the GHG emission of the material is negative. This negative emission is due to the embodied carbon in the timber. As of today, even if the market share is small, CLT is relatively cost competitive. However, some raise their concern regarding sound transmission and fire safety. Recycled aggregate concrete, RAC, showed great results in minimizing the waste of a construction site. The mechanical properties of the material have shown to be preferable too. Yet, the increased GHG emission of the concrete due to an increased amount of cement needed isn't preferable. Alkali activated concrete, AA concrete, showed lower GHG emission than the concrete used in Branddörren. However, the poor workability, increased corrosion and efflorescence occurring acts as a barrier for the material. The Eco-concrete using superplasticizers and limestone powder to decrease the usage of cement showed good mechanical properties. The GHG emission of the material is decreased significantly and the cost of it is still competitive compared to conventional concrete. Using a combination of concrete and timber have also shown to be a promising technology, especially for simplifying the integration of timber into the building sector.

Chapter-5

5. Social and Economic challenges

In this chapter the social and economic challenges for integrating new building materials and innovations into the construction industry is investigated. The social challenges consist both within the industry but also in general regarding regulations and incentives. The economic challenges primarily depend on the fact that the main aspect of competition is low prices. Therefore, the integration of new materials is tough, especially when the margins are low. Considering the building sector as a sociotechnical system, as described in the introduction, enables the categorization of barriers depending on their origin. In the building sector three different levels is defined, the project level, the sector level and the contextual level.

5.1 Project level

The project level is defined by the organization around a single building project with a definite timeframe. There are several barriers for integrating new materials within this level that could be defined. As a project have a specific project group, the knowledge and social acceptance within this group is a key parameter for the integration of new materials. This makes the work of integrating new materials project dependent. If no actor within the project have interest or knowledge in sustainable materials the implementation is difficult to carry out. Often projects lack goals and objectives, making the incitements for using new technologies even harder. As projects have a definite timeframe the implementation of new materials is limited due to this effort being time consuming as all actors within the value chain is affected. New suppliers of construction materials might be needed, resulting in a long process of procurement (Anund Vogel, Lundqvist, Blomkvist, & Arias, 2015). The actor of sustainability is a key actor both for the project and for affecting the social acceptance of sustainability work at the company. However, the workload on this actor could easily be overloaded (Kellner, 2017). The structure of feedback in projects are also limited. As the project group is a temporary group of knowledge, the challenges and the mistakes made is often forgotten. These repetitive processes are yet defended as they often make the projects time and cost effective (Anund Vogel, Lundqvist, Blomkvist, & Arias, 2015).

In the project level most of the actors lacks the knowledge of investment horizons and strategies of the company. This also acts as a barrier to the implementation of more sustainable materials as the main goal of the company often is forgotten and specific cost and time goals of the project is focused on instead (Anund Vogel, Lundqvist, Blomkvist, & Arias, 2015). In the case of Veidekke, and most of Sweden's construction companies, the project of Fossilfritt Sverige, described in the introduction, should force the projects to work towards lowering their emissions in a larger extent.

The building project named Viva in Gothenburg, Sweden, in 2015 shows how knowledge regarding sustainable building materials within the project group affects the end product. This flagship project led by construction company Riksbyggen chose to build in concrete despite that the general goal of the project was to present the latest technology within the construction industry and ensure sustainable development both environmentally,

with a framework of CLT, whereas the framework using CLT showed far greater environmental aspects. Yet, the company decided to build with concrete with fly ash as SCM, something that's been on the market for decades. The lack of knowledge and sense of unfamiliarity using CLT in residential building is presented as one reason to this. Another reason that influenced the decision was the uncertainty regarding the lifetime of CLT (Kurkinen, Norén, Peñaloza, Al-Ayish, & Doring, 2015). This decision of building in concrete due to the unfamiliarity using CLT could have been different in another group depending on the knowledge within it. This shows the uncertainty and sensitivity of sustainability work within projects.

5.2 Sector level

The sector level is defined by the companies, organizations and institutions being a part of the construction industry. This includes the construction companies and the subcontractors.

The construction industry, as described before, sense a feeling of awaiting. Actors within the value chain wait for one and other to wanting, choosing and producing sustainable construction materials (Rosengren, 2018). Social acceptance of new materials is also a tough aspect in the industry. The industry has in a large extent made itself path dependent on using concrete in new constructions. This is mainly due to the fact that concrete have been used in the industry the last decade and that the contact network between the concrete and construction industry is well established. Knowledge of building with concrete is well known in the entire value chain, contributing to the slow adaption of new knowledge within the business (Kellner, 2017). This slow adaption could also be an effect of the large momentum often linked to larger construction companies. The large momentum of knowledge, effort and funding needed to convert a company towards sustainability is aspects who affects the rate of accepting and choosing sustainable materials (Anund Vogel, Lundqvist, & Arias, Categorizing barriers to energy efficiency in buildings, 2015). The complicated value chain of the industry also add to the momentum as there are many actors who affects the social acceptance of new materials. Within a construction company all departments like business development, planning, purchase, production, sales, and management affects the integration. Aside from this the subcontractors, municipalities and authorities also affect and contribute to the momentum (Kellner, 2017).

Regarding the social acceptance using timber in multifamily houses, the number of actors within the industry considering CLT as the best option when constructing new buildings has grown. In 2015 only 13 % considered CLT as the best material for new building developments. In 2018, this number was 34 % (Hidalgo, 2018). This implies a fast-growing acceptance within the industry, opening for further usage of timber in multifamily houses. Despite the growing acceptance within the sector, the usage of CLT in multifamily houses is somewhat restrained by the regulations of Boverket, as described in the section of CLT (Kellner, 2017).

Considering the most important actor for all construction companies, the costumers, the work of sustainability has a growing importance. Regarding the costumers of new residential buildings, the demand of sustainable buildings is rising, as a part of a more sustainable living. The Swedish costumer no longer only base its choice of new resident based on price, location

and size. New investigations show the growing demand of possibilities for sustainable living. The ability to produce your own electricity and having a low energy demand are some aspects commonly presented. People interviewed in a recent survey believe in even tougher building regulations in the future and considered the work towards sustainability within a construction company as a competitive advantage when buying a new resident. This makes it crucial to work actively towards sustainability to appeal to the key customer of Veidekke and other construction industries, the residential customer. The work of sustainability and the goals towards it within a company thus need to be considered as a strategic business goal. Working actively with sustainability is key to make sure that the company stays relevant and appealing to the customers in the future. Accordingly, sustainability is an important, and growing, factor for competition within the market. Working actively with sustainability is also an important tool for attracting young professionals to work at the company. Many consider sustainability an important factor when choosing a job as they want to work and contribute to a company with a clear sense of sustainability and an action plan towards it (Kellner, 2017).

Commercial activities, hence constructing commercial buildings, are a business area of Veidekke too. As for the tenants, in other words companies, municipalities and organizations, working with sustainability is an important business strategy too. Having sustainable offices with small CO₂ footprints could be used to further amplify the sustainability image of the company and attract new customers. It could also be a part of an action plan for a municipality having sustainable schools etc. Here once again, companies and municipalities use their work for sustainability as a tool for staying relevant and attractive. Using certifications like BREEAM and LEED for the commercial buildings could be a good option. These certifications, origin from England and the US, are international certifications who aside from energy usage and other sustainability factors also consider the environmental impact of the building materials. Using these certifications could attract both international and national businesses to choosing sustainable offices as a strategic business choice and help integrating more sustainable materials into the sector (Kellner, 2017).

The employees at the construction companies are the most important actors for reaching a sustainable building sector. They have in-depth knowledge about the company, making room for great improvements based on their experiences. If these improvements towards sustainability is made in every level of the company, by the employees themselves, great advances could be reached. However, the work towards sustainability somewhat needs to origin from the board of directors and management in the company. This will deliver a sense of seriousness to the rest of the employees and show that the question of sustainability is important. This would lead to positive feedback from the employees, leading them to making more sustainable choices and in the extension also affect the subcontractors and other actors within the value chain. Sustainability is a question which transects the company in all its areas, from business development to planning, purchase, production, sales and management. In order to keep sustainability relevant, the question of sustainability needs to be a standing point on the agenda on meetings with the boards of directors (Kellner, 2017).

The implementation of new technology as often failed whereas the cultural aspects have been excluded. The adoption of new technology and the success of it depends on the perceived difficulty, commitment from supplier, perceived benefits, compatibility and enhanced values.

This is yet another reason for the employees being the main force towards sustainability. To succeed with sustainable implementations the behavioral patterns and structures need to be included to make sure that the entire work force understands the benefits and enhanced values in choosing more sustainable options (Au Kai-Ming & Enderwick, 2000).

As described in the introduction of the thesis, the primary source of competition within the construction industry is lowest price. This makes the integration of more sustainable materials into the sector difficult as many of them, at the moment, are more expensive compared with conventional concrete. This creates a lock-in for the industry to continuing the usage of nonrenewable and unsustainable building materials. Regarding funding, larger companies have an advantage as they simultaneously have larger assets. However, the large momentum existing in these larger companies is worth repeating. Therefore, smaller companies might be benefitted when change of materials and technology comes (Fossilfritt Sverige, 2018). Using innovations and new building materials is often coupled to the specific budget of the project, something that makes the integration more difficult. If no additional funding is given to R&D-projects, the budget often isn't sufficient (Anund Vogel, Lundqvist, Blomkvist, & Arias, 2015).

Due to the low margins of the industry, the fear of having a high-risk project often acts as a barrier for the integration of innovation. The industry is heavily path dependent to concrete due to the standardization and modularity of it. The common standards of concrete makes the planning and execution easy as every unit in the value chain understands and speaks in the same language. This acts as a barrier especially for integrating timber into the industry as it has orthotropic behavior, i.e. different properties in the three different main directions, as described before in the section of CLT. Due to the orthotropic behavior it isn't as easy comparing CLT with concrete and acts as a barrier of growth as people can't visualize the possibilities. The standards, codes and norms of the construction industry creates a lock-in to repeat the processes and construct a barrier of growth integrating new materials (Zaccaro, 2017).

5.3 Contextual level

The contextual level is defined as the rules and regulations set by authorities surrounding the construction industry. The weak national strategy of lowering the impact of the building process is considered as one important barrier for using more sustainable building materials. The national goals and municipal goals are incoherent and easily creates confusion (Anund Vogel, Lundqvist, & Arias, Categorizing barriers to energy efficiency in buildings, 2015). A law entered in 2015 by Sweden's housing minister at the time, Stefan Attefall, tried to minimize this confusion and boost the number of constructions by forbidding municipalities to set additional requirements onto the regulations from Boverket (BBR) of new developments. However, this law still makes it possible for municipalities to add additional requirements by developing an environmental program for the town (Kellner, 2017). This might create confusion in the work towards sustainability or stimulate it. By municipalities competing against each other, lowering the emissions from the building phase could grow to be a key aspect of these environmental programs.

As of now, Boverket isn't considering the impact of the building materials in their building regulations. Energy efficiency have been the main interest so far, but the impact of the building materials has grown interest since passive houses now is possible and fairly easily built. At the same time does the lack of integration of environmental effects of building materials show the maturity of the question on the contextual level. However, at the moment in Sweden there is a huge lack of housing. This acts as a treat to the social sustainability of a city. The economic growth and working opportunities could be restrained as a result of this (Kellner, 2017). This makes it crucial to produce cost and time effective buildings, a parameter that's also restrain the integration of new materials into the value chain.

5.4 Social and Economic challenges at Veidekke

As described before in this section, the work of sustainability is widely dependent on the employees of a company. The social acceptance and general perspective on the integration of more sustainable materials at Veidekke was developed by interviewing some of the employers. By conducting interviews with employers with different responsibilities within the value chain a general picture of the situation could be formed. To clarify the social aspects and acceptance towards sustainability at a construction site, the construction site manager for the project of Branddörren, Linda Björklund, described in the section of the reference wall, was interviewed. By interviewing the director of production development at VeidekkeByggBostäder, Sofia Dehre, the general picture of how the process of choosing materials and the barriers of integrating more sustainable ones was developed. Interviewing the manager of project development at Veidekke Bostad, Lina Brantemark, a general picture of how Veidekke is developing and pursuing projects according to the demands of the customers was established. Lastly, by interviewing the timber building manager at Veidekke, David Grimheden, the general work of increasing the construction in timber at Veidekke and the social acceptance surrounding that work was investigated.

5.4.1 Linda Björklund, Construction Site Manager, VeidekkeByggBostäder

As a construction manager Linda Björklund make sure that the construction site works as effective as it could by communicating with people in the entire value chain and maximize the collaboration between them. Linda have been working at Veidekke since 2005 and have worked with several different building techniques. At the beginning of her career at Veidekke she came across a construction using timber in the external walls. Problems in these external walls soon arose as mold started to spread. Restoring these walls later on resulted in higher costs for the construction. Linda, among others, are raising questions regarding the sound insulation, vibration in the beams and fire safety of the timber. Due to problems from the previous project Linda has some restrictions using timber as a construction material. However, she is also aware of the recent developments of the material. She's positive about the recent progress of using more timber in multifamily houses and is convinced that it still performs good as a construction material.

“Concerning the working environment, using timber is far more favorable.”

Linda describes how quiet a construction site using timber could be. When using concrete, the construction workers are used to high sound levels and heavy machinery. This is in complete contrast to how the environment is when using timber, were lighter equipment is sufficient

and thereby generating lower sound levels. As timber often needs to be covered during construction the working environment is dryer and more pleasant too. Concerning the prefabricated concrete elements being delivered to the construction site, many of the construction workers find this process less enjoyable as they rather would work with liquid concrete.

5.4.2 Sofia Dehre, Director of Production Development, Veidekke ByggBostäder

Sofia Dehre have been working as the director of production development at Veidekke ByggBostäder for 10 months. Previously she had a similar employment at NCC, another construction company based in Sweden, and before that she worked within the concrete industry, specializing in prefabrication for 15 years. At Veidekke she is responsible for increasing the productivity by improving the processes and methods. Since her time working at Veidekke is limited, the work of mapping the effectiveness and sustainability of prefabrication and materials used lies ahead. However, right now Dehre is part of the process of implementing a new type of plasterboard with less plaster and an increased amount of pulp fiber from timber into the production. Using this improved plasterboard results in less waste being produced as the dimensions of it are optimized for minimum waste. The improved transportation also contributes to a more effective process. If the plasterboard is more environmentally friendly or not is unknown but it should be as less plaster is used in the favor of more renewable wooden fiber. Due to the lower amounts of waste and the effective transportation the costs of this new plasterboard are comparable with the conventional plasterboard used previously (Dehre, 2018).

Dehre thinks that the media and advocates within the industry only presents the benefits using timber as a construction material and forgets the disadvantages. Dehre raises the opinion that constructing buildings by the principle of and old Swedish principle called Landshövdingehus, i.e. a county governor house. This type of building was common in the 1800s and is constructed with a ground level in stone and two stories using timber.

“Materials should be adjusted to the specific project and mixing concrete and timber is something that should increase.”

Looking into the construction industry of Sweden generally, several companies is developing and testing new types of concrete and asphalt with lower CO₂ emissions. However, these alternatives often can't have an additional cost comparing with conventional materials. This is a strong reason to the difficulties of integrating new materials into the business. The industry has also grown dependent on international trade of building products, resulting in long transportation distances. Working on lowering the transportation Dehre think is a good way towards sustainability. Using local businesses should be investigated and rewarded.

Dehre have experienced several cases were costumers, in this case municipalities, have asked for constructions using timber. This decision however has been drawn back later in the process as the additional costs using this material was presented.

“The margin of the industry is extremely low, to integrate new materials we need a higher ability to pay for it from the costumers.”

As of today, the margin within the industry usually is around 3 %, leaving few opportunities for improvements. To increase the margin either the building process needs to be more effective and thereby more cost-effective or the quality of the product need to increase and thereby making the costumers want to pay a higher price for it. By having a company that is project based Dehre have seen several cases on the low frequency of improving the building processes further. As an example, she explains that the plasterboard using less plaster have been available for several years but haven't been used anyway. She explains that the building sector in general have problems in their organization. Veidekke as an organization, among other construction companies, is decentralized and heavily project based. This results in low level of feedback, resulting in the business being repetitive. As of now, if large changes were to be implemented, one would have to inform and instruct each person in the value chain of a project. Dehre describes a building project as a temporary factory. In this temporary factory new rules, stakeholders and organizations is occurring which altogether act as a barrier for implementing innovation. Dehre believes a part, or total, matrix organization is a preferable to use in a construction company.

“As of today, construction companies are way to outdated.”

During the time Dehre worked at NCC they partly changed their organization to being matrix based. The goal of the rearranging in the organization was to have a unit of specialists transecting all other activities in the company. This unit then would work as a central component supporting all the projects of the company. The implementation of this reorganization was tough and took over five years completing.

“As of now, at Veidekke and in the Swedish building sector, it's difficult to push development forward.”

At the question of how willingly Dehre perceives the social perception of using more environmentally friendly materials at Veidekke she answers that as of now there isn't a large will to pursue these issues. As of now, when the specific implementation of a material would be funded with the budget of the project affected, the development is pushed into the future. This contrasts with a traditional industry were an R&D department develop an idea or product separately from the business of the company. In the building sector the development and implementation of new products are made directly into the projects. Thereby the funding of the implementation of innovation is based on specific project budgets.

“You often hear people say ‘Please try, but not in my project’.”

5.4.3 Lina Brantemark, Business Development, Veidekke Bostad

Lina Brantemark is working as a business developer at Veidekke Bostad. The main responsibilities Lina has is to acquire and sell Veidekke's property portfolio and make sure the projects being developed in the most strategic way. Lina is not sensing that high priority of sustainability in the subject of environmental issues. She rather senses a larger weight on creating social sustainability. The customers demanding higher requirements of social sustainability is often the municipalities that announces the allocation competition, i.e. a competition were construction companies compete against each other to win the specific

project. By these allocation competitions there are often a long list of requirements or properties wanted by the municipalities that increases the chances of a project from a construction company to win. In these allocation competitions Lina have sensed an increased demand for creating socially sustainable spaces. The demands are often based on the idea of mobility, were the possibility of having a shared car pool, space for bicycles, a refrigerated space for delivered groceries and flexible shared spaces is rewarded. Creating different forms of ownership is also an important property, for example mixing rental and tenant ownership.

“The customers buying an apartment today doesn’t choose another actor depending on sustainability, it’s a case of other properties.”

Lina doesn’t believe customers choose to buy a specific apartment depending on sustainability. The question of location and floor plan is of much higher importance. The customers demanding higher requirements of environmental sustainability should rather be appealed to the timber buildings developed by Folkhem Lina says. The municipality of Stockholm have high demands in social sustainability due to research done showing the segregation occurring. However, Lina raises a question mark if developing social sustainable buildings are possible in areas where the land price is as high as it is in Stockholm.

5.4.4 David Grimheden, Department Manager Timber Buildings, VeidekkeByggBostäder
David Grimheden have worked at Veidekke for 17 years and was previously responsible for the department constructing multifamily houses. A year ago, he became responsible for the department of timber buildings at Veidekke, ByggBostäder. In Norway, where Veidekke have their biggest market share, the demand of timber buildings has grown recent years. By the projects built in timber by the company, Veidekke is considered as the leading actor of timber buildings in Norway. Since Veidekke acquired parts of the company Folkhem one and a half year ago the development of building with timber in Sweden started. Folkhem is another construction company based in Sweden only constructing timber buildings. Acquiring this company gave Veidekke the required knowledge for constructing in timber. Grimheden had the responsibility developing the team of the department and today there is five members (Grimheden, 2018).

The goal of the timber building department is to act as technical specialists when constructing in timber. At the moment they have around 10 projects in Sweden where three of them is planned in the near future. One project is planned to begin in February 2019.

“Mainly the competition is based on price but being sustainable in the long run is important.”

The strategy of the timber department is to have a great level of knowledge development of building in timber and make the constructions of timber economically competitive in the future. Grimheden repeated the importance of having long horizons when looking at economical sustainability. In the short horizon, building in timber might be less cost efficient, but by considering a longer timeframe the importance of sustainability is easily defended.

“Developing knowledge is expensive, but that’s OK.”

Grimheden sense a large interest of building with timber in the rest of the company. Many employees consider the material as exciting, something that’s topical and something that the costumers beginning to demand. The importance of adjusting the materials to the project is of

Chapter-6

6. Stakeholder and market mapping

By defining the stakeholders that influences the integration of more sustainable building materials into the construction industry a stakeholder mapping is conducted. This illustrates the market and the critical stakeholders who needs to be managed closely. The push and pull phenomenon's of the market will also be investigated. By having a top-down perspective the push phenomenon's that are "pushing" the market into being more sustainable could be studied. By then having a bottom-up perspective the pull phenomenon's of the market could be investigated, factors that "pulls" the market into using more sustainable building materials.

6.1 Stakeholders

The construction industry, as described before, is built up by a complicated value chain. By the definition from industrial dynamics the construction industry is considered as a sociotechnical system. This definition states that the sector is built of many different technologies, actors and institutions, all rooted in our society. Therefore, there are many actors affecting and that will be affected by the integration of new building materials. The rate of interest in the integration is also varying depending on the stakeholder. Firstly, the role of the construction companies is important for the integration. Veidekke and other construction companies are important stakeholders who could push the market by more sustainable choices. The construction companies themselves have a complicated value chain within the project organization were business development, planning, purchase, production, sales and management all are affected by the usage of new building materials. The business developers need to work actively with innovation to choose new building materials and make sure the planners and the ones responsible for procurement make more sustainable choices (Kellner, 2017).

Other important stakeholder for the integration are the construction workers, the fundamental workforce that make sure that a building is developed from plan to completion. Without considering the knowledge and social acceptance of the construction workers, the integration of new building material could face barriers (Björklund, 2018). The concrete and timber industries are also important stakeholders. These are the major forces for developing new solutions of construction materials (Wählinder & Crocetti, 2018). The timber industries have an interest of growing their market share and spread the knowledge of the advantages using timber as a construction material in multifamily houses. The concrete industry on the other hand have an interest of distribute their sustainability work and their plan for a sustainable building sector. Other construction companies are also an important stakeholder as they provide the competition to the market. Using sustainability as a tool of competition is rising and therefore the interest in the sustainability work of the competitors are important to monitor and follow up.

Other stakeholders having interest in using new building materials are municipalities and the government. By the goals set by the government, they and the municipalities need to work actively to influence the construction industry to being more sustainable. The UN are also a stakeholder due to the Paris agreement made in 2015, were the majority of the countries in the UN agreed on working actively on sustainability. The EU are another powerful stakeholder who could change the regulations in the industry. Boverket and other authorities influencing the regulations of construction are important stakeholders too. Researchers and media are also important stakeholders to diffuse the knowledge about new construction materials and make sure the development is continuing.

The costumers are another important stakeholder to work closely with. As described before there are a rising number of costumers demanding more sustainable choices of living. Ultimately, it's the costumers pulling the market and assuring their needs is a key parameter to succeeding.

6.2 Push phenomenon

By considering the market from a top-down perspective, large authorities like the EU and, in the case of the Swedish construction industry, the Swedish government have large potentials for pushing the market into more sustainable choices. Several plans of actions have been developed and signing the Paris agreement could be seen as the ignition to more concentrated work towards sustainability being established. From these plans of action several regulations and laws that pushes sustainability into the market have been established. Considering sustainability as a key parameter in the work of these authorities pushes the market into the same pathway.

Currently many municipalities in Sweden set high requirements for new building developments despite the law forbidding this, described in the previous chapter. However, having these local additional requirements is an effective way of pushing the local market towards sustainability. If the municipality set their own action plan towards sustainability the work establishes a local connection and a natural boost. This could be seen in several municipalities in Sweden who have been developing a framework for pushing the local building sector. In Växjö, southern Sweden, the municipality have set a goal of building 50 %

of their buildings in timber 2020. This is a part of the local goal of having the municipality of Växjö fossil free 2030. Building in timber is also a part of developing local manufacturing of building elements and a tool for securing job opportunities in the rural areas of the municipality. This is a clear example on how the local government could push the local market into sustainability (Växjö kommun, 2018). Implementing this type of sustainability into the local construction industry shows the positive effects when working with smaller institutions. Rather than letting the government implementing a goal of increasing the amount of timber buildings, having a municipality with smaller momentum developing an action plan instead shows the effectiveness. As the municipality, in the case of Växjö municipality, owns both the construction company and the right to develop sustainability goals, the work is effective. Another example of local regulations pushing the market into sustainability is the area of Värtan in Stockholm who developed an action plan for the area who's ultimately tested by the allocation competitions. This demanded the contractors constructing buildings in the area to work more sustainable.

The building authority, Boverket, have a key role in pushing sustainability into the building sector too. The regulations set by Boverket affects all buildings and as of today high requirements are set on energy efficiency and minimizing the effect during the operational time. However, as stated in this report the environmental effect from the production phase is significant and something that should be integrated in the regulations too. By integrating regulations on the use of resources and emissions, the construction industry could be pushed towards choosing sustainable construction materials. Redeveloping the voluntary certificates often used by construction companies, like Svanen, BREEAM, LEED and Miljöbyggnad is an important tool too (Liljenström, o.a., 2015). Svanen is a certification used for all multifamily houses built by Veidekke. This certification concentrates on choosing energy efficient solutions in all steps, having low energy usage and providing a non-toxic living environment (Veidekke Bostad, 2018). The environmental effects from the building phase, however, is excluded. The other certificates have similar goals and some of them disregard the emissions from the construction phase too. Having a certification regarding the emissions from the materials used could be a good tool for pushing the market, but also enable an advantage in competition for construction companies who's early with certificating their buildings as sustainable during the construction too (Liljenström, o.a., 2015). In the Netherlands there is regulations demanding the usage of LCA during construction, and something that Boverket currently have started to investigate. Using additional certificates as BREEAM, a certificate who account for a more general picture of sustainability than Svanen, could, as told before, be preferred especially in commercial buildings as the certificate is international and could attract international companies. The certificate regards the energy efficiency, the building materials, use of water, waste management and how it affects the surrounding environment (Kellner, 2017).

6.3 Pull phenomenon

By having a bottom-up perspective the pull phenomenon's could be identified. The pull phenomenon's enable the push phenomenon's to reach their full potential as they are the main force for increasing the social acceptance for the technologies. As described before, the demand of more sustainable living options is rising and something that the residential

customer is considering when buying a new home. As the customer is the most important stakeholder for all companies, their demand is always the key for succeeding. Therefore, the construction industry should use sustainability as a tool for competition and always keep the needs and expectations of the customer close to their own strategies.

The need of new developments, especially in large cities with a high rate of urbanization, could be considered as a pulling factor from the market. The high rate of urbanization requires fast and sustainable buildings. Media and researchers are important pulling factors as they help the distribution of knowledge and interest of sustainability into the market.

Concluding remarks

The building sector is built by a complicated value chain of actors, some more important for the implementation of sustainable building materials. To reach a higher rate of sustainability within a construction company the business developers and purchase departments are considered to be some of the key actors. The timber and concrete industries are important for the development of new materials and solutions. The costumers are a key actor too, they are the ones ruling the market. The most important actions to push the market into sustainability could be made by the municipalities and Boverket. The key actor for pulling the market is the costumer demanding more sustainable buildings.

Chapter-7

7. Results and discussion

In this section the results of analyzing the different investigated building materials will be presented. The materials are analyzed depending on the results from the KPI:s presented in the tables of each material in the literature study. To deepen the analysis two materials with the most promising results will be investigated further. The salient and reverse salient of these materials will be presented in relation to a S-curve. Later on, the 3D approach will be applied to further clarify how the new materials could be integrated into the sector. Critical stakeholders for integrating more sustainable building materials into the sector will be investigated and lastly presenting the key innovation opportunities.

7.1 System analysis

If the materials investigated in the literature study is plotted depending on their cost and CO₂ emission per square meter wall, corresponding to the values presented for each material in the literature study, the diagram seen in Figure 11 below is created. As RAC both have higher CO₂ emission and a higher cost compared to the reference wall further analysis regarding this alternative won't be made. AA Concrete reduces the CO₂ emission slightly, however, the price of the material is considered to be 10 % higher than the conventional concrete. Also, when comparing the CO₂ emissions using Eco-concrete and CLT these reductions are far more impressive. Regarding these results, further analysis will concentrate on the possibilities for using CLT and Eco-concrete as building materials.

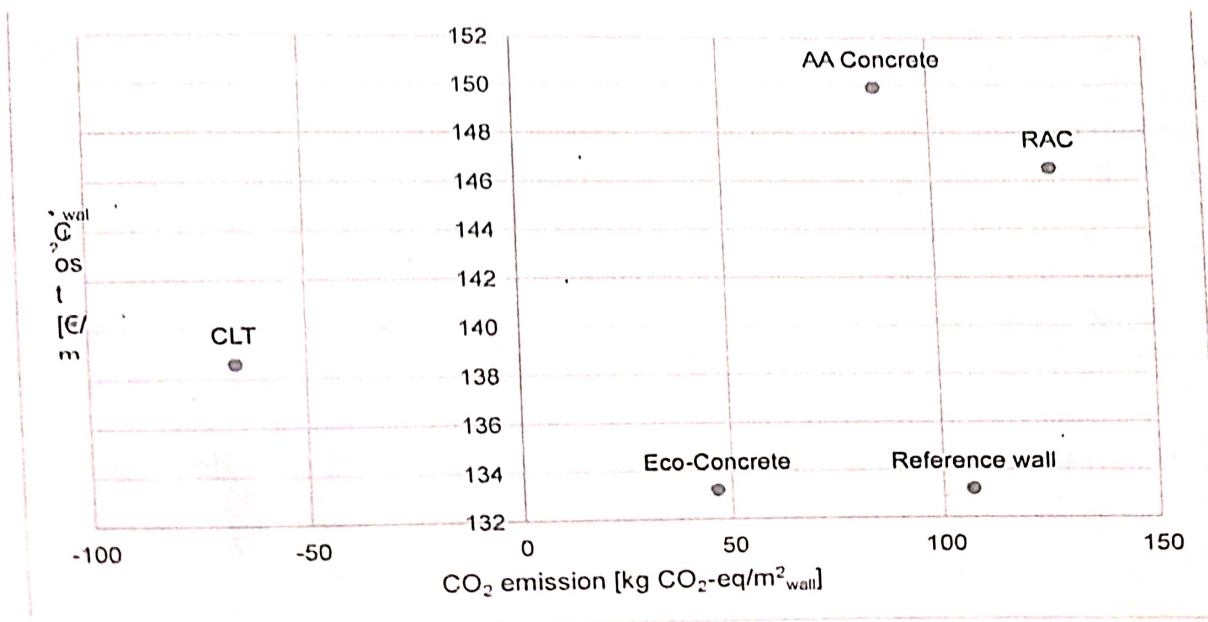

Figure 11. The investigated materials plotted depending on cost and CO₂ emission per square meter wall

7.1.1 System analysis of CLT

The evaluation of CLT is presented in Figure 12 below.

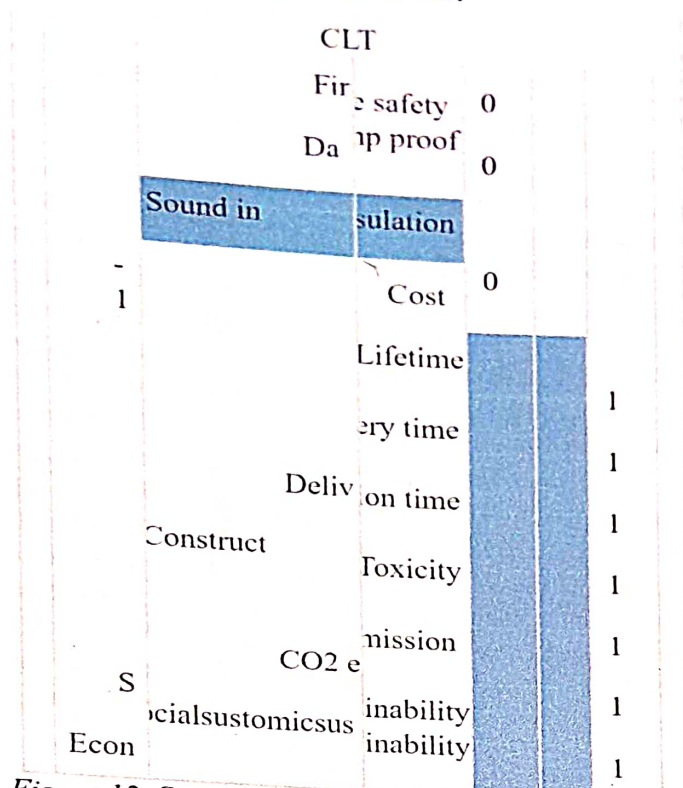

Figure 12. Salient and reverse salient properties of CLT

The usage of CLT as a construction material has several advantages. The cost, as of now, is somewhat competitive to conventional concrete despite the small market share. Currently building with CLT is 10-20 % more expensive comparing with conventional reinforced concrete. If the market share of CLT were to grow, the competitiveness between manufactures and contractors would increase, which could lead to a reduction in cost of CLT. An increased market share would develop the knowledge about building with CLT and contribute to an improved performance of the buildings constructed. The use of the material would also develop a sense of familiarity to the material in the entire value chain, minimizing the barrier of growth for the material. The domestic industry of timber in Sweden is also a large force for manufacturing and simplify the usage of CLT in buildings.

Concerning the fire safety of a building constructed in CLT, the regulations from Boverket are fulfilled. However, these regulations only consider the personal safety and do not encounter for possible damage to the building. The most popular solution for fulfilling the regulations from Boverket regarding fire safety in timber buildings today are sprinkler systems. The materialistic damage possible with this system could be extensive and so create a barrier to constructing with CLT. Development regarding fire safety in CLT buildings are crucial to further implementation and is currently a problem raised by the insurance companies.

The characteristics regarding damp when constructing in CLT are both beneficial and disadvantageous. During construction the working area needs to be covered to make sure the timber isn't affected by the damp in the surrounding environment. Before being assembled at the construction site the CLT elements need to be stored correctly too. If they aren't stored properly the chances of damaged linked to damp is amplified. However, working in an enclosed environment contributes to a more pleasant working environment for the construction workers. The sound levels when constructing with timber is also significantly lower comparing with concrete due to the lighter machinery needed. The sound insulation is a reverse salient as problems regarding sound and fluctuation is a problem when constructing buildings in CLT. The sound regulations of Boverketis, however, fulfilled. The problems of sound transmission and fluctuation origin from the low weight of timber, a property which is considered as an advantage in other areas. However, sound travelling through timber is considered as more pleasant comparing with sound travelling through concrete. Therefore, the difference in sound transmission should be viewed as a possibility for creating more pleasant indoor environments for people using the buildings. The low thermal conductivity of the material is also a property contributing to a more pleasant indoor environment and makes it possible to lower the amount of heating. As the low thermal conductivity enables storing of heat, the heating demand could be lowered. This heat stored in the building would in the case of a concrete building be ventilated out and ultimately demanding more heat. This property of timber makes it possible to lower the indoor temperature with a few degrees and still act pleasing. These abstract qualities can't be forgotten as they contribute to a better living environment for the costumers, and something that could be promoted as an attractive advantage of living in a timber building.

The delivery time of CLT is considered a salient property as the industry in Sweden and Scandinavia is currently increasing their manufacturing. The domestic industry surrounding timber in Sweden heavily contributes to the GDP of the country. The timber industry is also the main force for developing new technology and solutions regarding CLT. The minimized construction time using CLT is also a salient property. Constructing in CLT have shown to be half the time as the same construction using concrete. Working in dense urban areas this is something that should be considered. In areas of high urbanization, rapid construction is preferable. The minimized disturbance due to lighter machinery should be considered too, as well as the improved working environment described both in literature and during the interviews at Veidekke.

The negative CO₂ emission is definitely a salient property promoting the usage of CLT. It's the only building material investigated having a negative CO₂ emission. This negative emission is based on the embodied carbon in the timber. The carbon savings made when using CLT instead of reinforced concrete in a building is equal to the emissions made during 10 years of the operational phase. Looking in an LCA perspective, i.e. encountering on all emissions from cradle to grave, carbon savings are made during all the life stages, with a general saving of at least 10 % comparing with a concrete building.

The social and economic sustainability of CLT is considered salient properties of this material. Using renewable sources of materials is considered as a key aspect of creating

sustainability, i.e. not being path dependent on conventional, nonrenewable sources of materials. The possibilities of creating both social and economic sustainability in the future using CLT are becoming more accepted, and Veidekke themselves have created new business ventures constructing with CLT. They have a plan of this building material being economic sustainable in the future. The interviews showed mixed emotions concerning CLT and other more sustainable options to conventional concrete. The interviewed employees as Veidekke sense a great expectation to the sustainable options but still waits for one and another to choose it. No one is really prepared to choose it in their own project due to the low margins of being profitable. The extra time needed to develop the knowledge within the project group is also limited and acting as a barrier. By having economic sustainability, the social sustainability is easier accomplished as new houses is developed, and when using CLT constructed faster to ensure housing were urbanization is occurring.

7.1.2 System analysis of Eco-concrete

The results of the system analysis of Eco-concrete is presented in Figure 13 below.

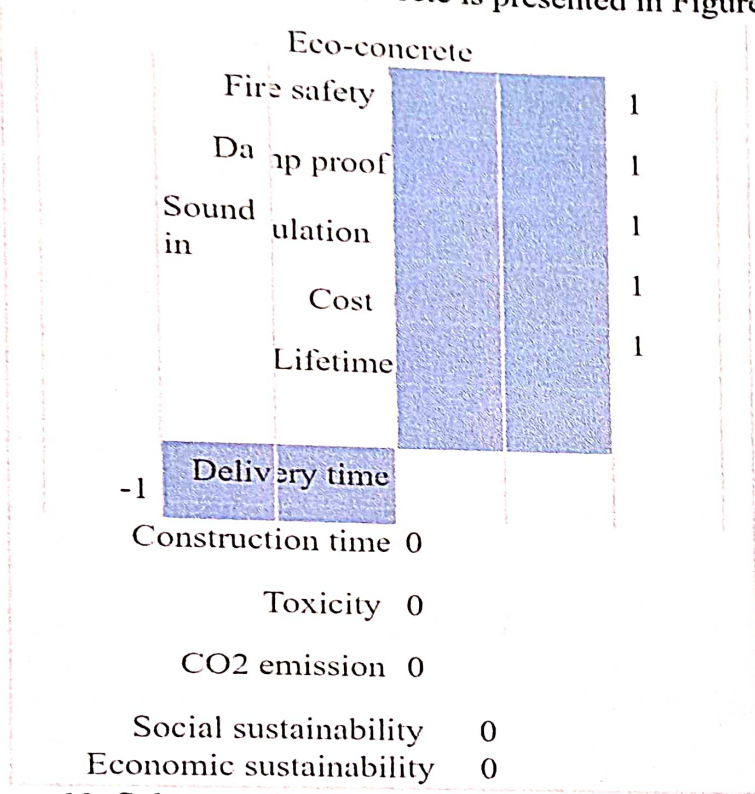

Figure 13. Salient and reverse salient properties of Eco-concrete

Comparing with the results from Eco-concrete, the properties lacking behind in CLT, i.e. fire safety, damp proof and sound insulation are in the case of Eco-concrete salient properties. The Eco-concrete, despite the lower carbon emission, continues to perform as conventional concrete regarding these properties. The lifetime is also a salient characteristic as it's considered to be the same as for the conventional concrete being used today. Another benefit using Eco-concrete is the familiarity with the material within the value chain. As described before the sector has made itself heavily path dependent to concrete and by using this concrete with proper carbon savings comparing to conventional concrete, the implementation

of it should encounter less barriers. The standardization of concrete is known in the entire sector and makes it simpler to choose a more environmentally friendly concrete and still know and understand exactly what the end product will be like. Therefore, the knowledge and technology already existing in the sector could be used to implement this type of concrete. The cost of the Eco-concrete is also a salient property as it's found to be the same as for conventional concrete, or even lower. However, producers delivering this type of concrete to Sweden is unknown and is something creating a barrier to implement this concrete into a project. Therefore, the delivery time is set as a reverse salient as proper implementation of the concrete in building project is limited to only few applications. However, the modified concrete mix used to create the Eco-concrete is very similar to the mixture used to produce the concrete elements in the reference case. The concrete used in Branddörren uses small amounts of both limestone and superplasticizers. Increasing the knowledge in the recent developments of concrete should therefore enable the manufacturing of a concrete with decreased GHG emissions in a fairly easy way.

The time for constructing a building in Eco-concrete is considered the same as for conventional concrete. Toxicity is also referred as an unchanged property of the concrete compared to the concrete used in Branddörren. This level of toxicity is low as its only toxic during the construction if dust is created and then inhaled by the construction workers. The living environment is, however, performing as a non-toxic environment according to the regulations of Svanen, followed by all multifamily houses built by Veidekke. The reduction in GHG emission producing Eco-concrete is around 50 % comparing to the concrete used in Branddörren. Even though the carbon savings are markable, it cannot be compared to the savings made when using CLT. Working with modified design mixing is without question a way forward for producing concrete with less GHG emissions.

Regarding the social sustainability using Eco-concrete there are several questions arising. Having a material still being dependent on the use of nonrenewable resources continuing the promotion of a non-sustainable way of living. Even though the concrete may be easy to implement in the industry initially, it doesn't encourage people thinking and solving problems differently. The cement and some of the aggregates used in concrete is of nonrenewable sources and considering fly ash and slag as renewable is under questioning. The fly ash and slag are byproducts of fossil-heavy industries and by considering it as a byproduct the origin connected to heavy emissions are forgotten. However, if research and new regulations would state fly ash and slag as nonrenewable, the use of the products as a SCM will be questionable too. This is mainly due to the GHG emissions of a concrete using fly ash or slag wouldn't be reduced compared to conventional concrete. As of today, there are also rules regulating the amount of fly ash and slag being acceptable in a concrete mixture. The economic sustainability of the Eco-concrete follows the same principle as for the social sustainability. The implementation and use of the concrete might be profitable as of today but could face barriers in the future. If future regulations would prohibit the usage of Eco-concrete or components within it, a company with a path dependency to concrete products, faces severe problems.

7.1.3 The S-curve of innovation adoption

To develop a better understanding on the maturity and possibilities for CLT and the Eco-concrete the materials are placed in a S-curve, seen in Figure 14 below. This illustration describes in which phase the materials are, market share, phase of adoption and level of performance (Kucharavy& De Guio, 2007).

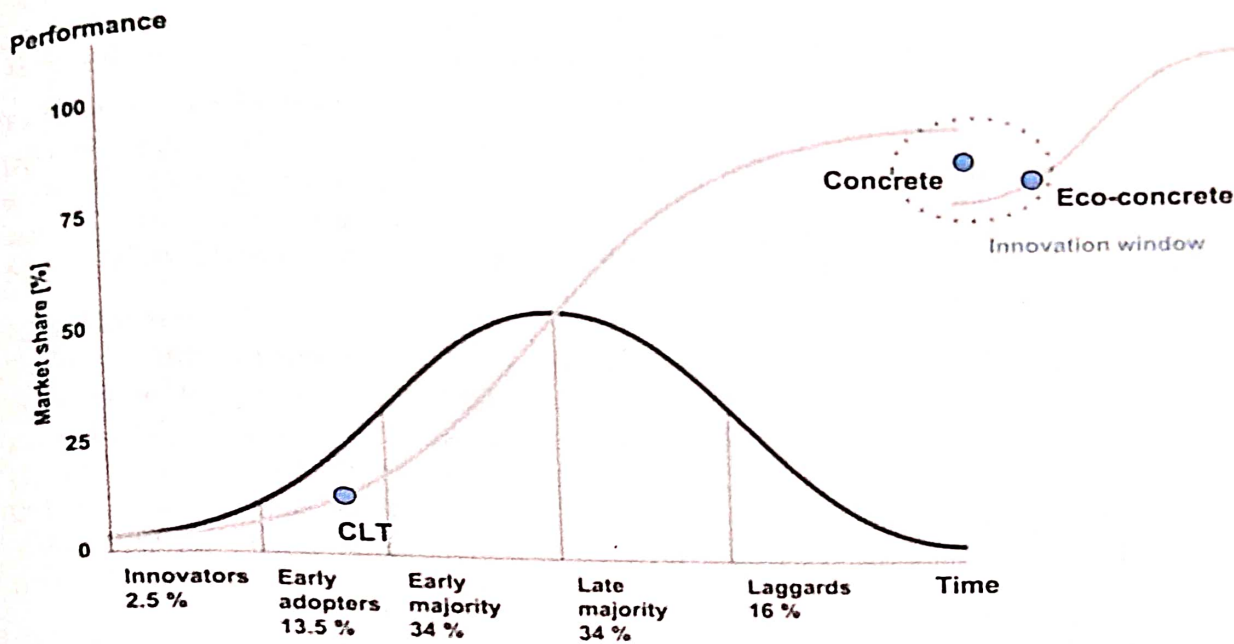

Figure 14. The S-curve of innovation adoption and the position of CLT and concrete (Schunter, 2014)

CLT is currently in the phase of early adopters. Some companies have implemented the material into actual multifamily houses and proven the possibilities for using it as a construction material. The market share is still very limited but continue to grow. The performance of CLT is rising parallel to the growth of knowledge on how to use the material most effectively. Being a part of the market share in the phase of early adopters are a strong action for competition later on. As the material reaches the early majority, having the knowledge and experience using the material will result in advantages against other companies who lacks this knowledge. Gaining market shares is then easier and enables to push the technology even further. Choosing to build with CLT in the early phases could then be considered as a strategic choice for developing knowledge to be competitive in the future. However, choosing to build with this material in the phase of early adopters results in higher risks but at the same time open up for possibilities of future benefits and higher profits. Develop the knowledge of building with CLT early minimizes the risk of leaving the profit to somebody else.

Producing conventional concrete have reached the level were a transition needs to be done. Adoption to new technology and innovation needs to be done to keep the material relevant and competitive in the future. A new wave of innovation regarding concrete is currently taking place, whereas in this report the Ecoconcrete seems the most promising. One could

describe the placement of concrete in an innovation window were large innovative solutions could make or break the development of more sustainable concretes. As of now the Eco-concrete is placed in the phase of innovators but increasing the number of applications could move the material to the phase of early adopters. Simultaneously the performance of the concrete would increase and enable further innovation. The new wave of innovation regarding concrete is of essence to enable the use of the material in the future. If the Eco-concrete were to develop an increased market share the price could simultaneously be decreased and make it even more competitive comparing with conventional concrete.

7.2 Innovation 3D approach

Developing the most promising pathways for innovation is key for innovation to succeed. By applying a "3D approach" a complete agenda could be created. The "3D approach" aims to benefit more *diverse* and *distributed* forms of innovation in different *directions* (Leach, Sustainability, Development, Social Justice: Towards a New Politics of Innovation, 2012).

7.2.1 Direction

To develop the best pathway for integrating new building materials into the sector a clear plan of *direction* needs to be stated. This could be defined by political prioritization in the sector, i.e. political choices that enable a clearer pathway for the new technology and innovation (Leach, Sustainability, Development, Social Justice: Towards a New Politics of Innovation, 2012). These political choices could be done by all levels of authorities, from defining an action plan for the member countries in the UN to making political prioritizations in a municipality.

The UN and the Paris agreement have a goal of generating clear pathways towards fulfilling the end goal of keeping the global temperature increase below two degrees. This is an action plan defines the rules for all authorities below and have a great impact. As most of the members in the UN have signed the agreement, the power of the agreement is massive. This agreement forms a sense of seriousness to the problem and enable the EU and the Swedish government to form action plans themselves. The Swedish government have stated the goal of having a construction industry with zero net emission 2045. This goal is supported by the action plan Fossilfritt Sverige, described in the introduction of this report. This action plan now needs to have more defined and clear pathways to succeed. Rather than letting the industry to slowly integrate more sustainability into their work, incitements developing knowledge in a sustainable construction industry should be presented. These political choices then make the direction for the companies in the values chain clearer and more concentrated. Otherwise, the work towards sustainability easily could become straggling and in the bigger picture only contribute to small reductions in GHG emissions.

Boverket could also be an active part by working actively with questions regarding the emissions of building materials. As the building authority in the Netherlands, Boverket should also consider the usage of LCA models as a requirement. This would benefit choosing environmentally friendly building materials and improve the sustainability of the building in all life stages. Political prioritization in a municipality and the benefits that could be created by this is previously presented in the example of how the municipality of Växjö, Sweden, acts to integrate more timber into their new constructions. Here, political choice gives the

functions within the municipality a clear direction of action and creates an action plan rooted to the inhabitants of the municipality. It also enables an economic and social sustainability to the municipality due to the possibilities of local employment.

7.2.2 Distribution

The property of *distribution* considers questions regarding the market share and who will benefit or misfortune from it. This often creates a gap between the goals of reductions and the interests in them by companies and countries (Leach, o.a., 2012). However, as of today, the concrete industry is well aware of their nonrenewable origin and that creation of sustainable concrete is key to stay relevant. The concrete industry owns a majority of the market share concerning building materials as there are no obvious opponents. Therefore, the integration of new building materials through incitements and prioritization shouldn't be considered as a threat to the concrete industry. A higher level of competitiveness is needed to create a healthier environment of competition and would benefit the usage of innovation in the entire industry, even in the concrete industry. By benefitting low carbon alternatives, the risk of using them is lower. The integration of new materials into the sector also develop new networks between the manufactures and the industry. This would increase the familiarity to the new materials and help minimizing the barriers of growth.

The timber industry in Sweden is large and should create great funding to research and development regarding new timber products and create a level of standardization and modularization to the building material. Using timber products in the building sector would then benefit the domestic industry of timber and help minimizing the trade of building materials and products with long transportation distances. Using building materials with low transportation distances is one simple solution to lowering the GHG emissions.

7.2.3 Diversity

The last property to approach is the property of *diversity*. This states that action plans and goals should promote several pathways and nurture them, resulting in social and technological diversity of innovations. By promoting fare more diverse solutions it fosters more robust and resilient innovation pathways in the future. This will then minimize the risk of having a lock-in similar to the one existing now towards concrete. By having a diversity of innovations, the building materials could be used depending on the specific project and its properties. For innovations in general its very rare having an innovation that fulfill all desirable requirements, therefore the integration of them needs to be adjusted for each specific case (Leach, o.a., 2012). This advocate the principal of choosing the right material at the right place. In a dense urban setting, choosing to build in timber might be favorable due to low construction time and the minimal disturbance to surrounding environment. Using timber to densify an urban environment could also be advantageous due to the low weight. Additional housing on existing one or construction made on weak ground that doesn't accept heavy loading, areas of decking for example, timber is favorable. In environments with though climate and strains, concrete might still be the most preferable material due to the great durability against external stresses.

Creating hybrid solutions with concrete and timber is a described technology with great potential. The mixture of the materials benefits the advantageous properties of each material.

The low weight of timber, resulting in higher levels of swaying and lower sound insulation, could be solved with the robust properties of concrete. The technology improves the GHG emission of a building and could be a great technology to initiate the movement towards even lower GHG emissions. The hybrid solutions of construction would then give the sector both time to improve the familiarity to the material but also time for developing a standardization and modularization of timber products. Having a standardization of products, seen in the concrete industry, is a great tool for letting the entire value chain understand and see the possibilities of a material. Working with timber concrete hybrids were also a technology brought up with great potential during the interviews at Veidekke.

As the process of manufacturing cement is CO₂ heavy due to not only the high demand of heating but also due to the chemical process releasing large amounts itself. Some researchers indicate that the usage of CCS, Carbon Capture and Storage, is key to redevelop the building sector towards sustainability. The technology is based on capturing carbon emissions and storage it in the bedrock. This technology could be used as a complement in the building sector during the time when material change is done to ensure that the goal of net zero emission 2045. However, becoming path-dependent to this technology would be dangerous as it encourages the continued usage of nonrenewable sources.

7.3 Critical stakeholders

In Figure 15 below a map of the stakeholders presented earlier is illustrated. They are placed in the diagram based on their power and interest in the integration of sustainable building materials in the building sector. The difference in power and interest forms four different categories of stakeholders. There are stakeholders which must be managed closely, keep informed, keep satisfied and ones to monitor. The mapping of the stakeholders clarifies which stakeholders who are highly important and that needs to be involved to succeed. The stakeholders are color coordinated depending on their attitude towards the integration. Green stakeholders advocates and supports it. Red stakeholders prohibit the integration and yellow ones are neutral to the development (Thompson, 2018).

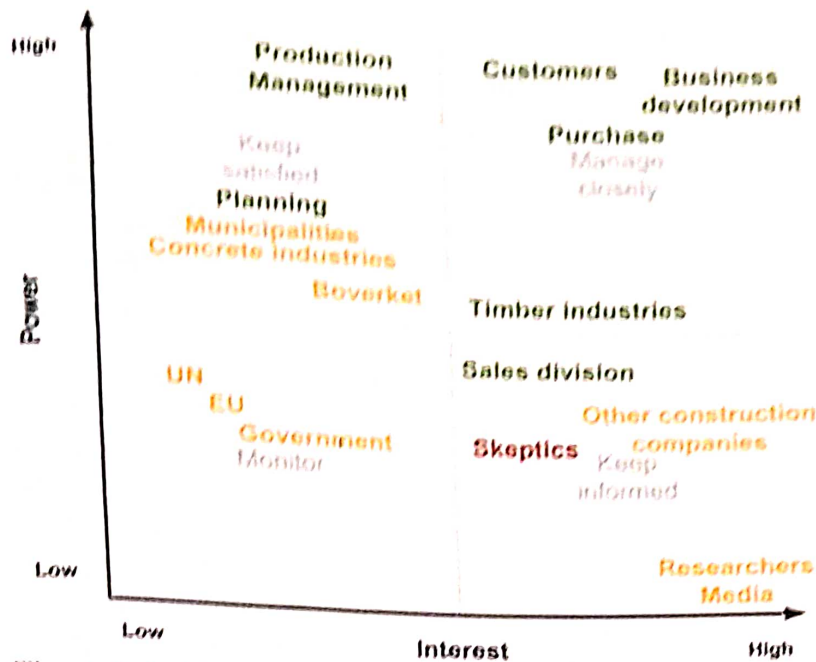

Figure 15. The stakeholders of integrating more sustainable building materials into the building sector (Thompson, 2018).

7.3.1 Manage closely

The key stakeholders to integrating new materials into the building sector is found to be the customers, the business developers and the division of purchase. The customers are important in demanding sustainable options and buildings. Business development for pursuing new projects with high set goals of sustainability and make sure the entire value chain works towards the end goal. Business development have the chance of making sustainability a strategic choice of competition. The division of purchase have high responsibility in having the knowledge to choose sustainable products and are the ones having contact with the rest of the subcontractors. By developing knowledge in sustainable choices, regarding the three pillars of sustainability, a change towards it in a cost-effective way could be reached. Timber companies are the main researchers of new building materials and solutions using timber. As the timber industries of today have a limited market share the development of new building materials that offers large GHG reductions could be a great tool to increase this market share. Connecting the knowledge within these businesses with researchers, the academia and the construction companies could stimulate the research on new building materials and showcase the need of them. This would also lead to an improved network between the stakeholders.

7.3.2 Keep satisfied

The production team and the management of a construction industry are stakeholder with high power but could have less interest in the work of integration. The concrete industries are an example of a stakeholder with this approach. Their market share regarding building materials are major, but the will to change and challenge the products of today are small. To create a more sustainable building sector the concrete industries should invest more interest in the question and move towards a stakeholder that one should manage closely. Another stakeholder to keep informed are the section responsible for production. This department

needs to develop knowledge in how new materials could be integrated into the process. If the materials used changes the process of work, knowledge about it needs to be developed to increase the familiarity of it. As described during the chapter of social challenges, the management of a company have high power in influencing the employees in working towards sustainability. The question of sustainability in all its three pillars needs to be a part of the strategic work towards a viable future. Management have a key role in dividing an end goal into sub goals and actual work of action. This is key to make the employers understand and work towards the end goal.

The division of planning are another division that needs to be kept satisfied. To satisfy this section the design process of integrating new material needs to be simple. Developing a standardization and modularization to the new materials would enable a smoother implementation. Municipalities and Boverket both have quite high power to integrate new building materials into the sector. Municipalities could have their own action plan were only construction in sustainable building materials could be a requirement. This would force construction companies to develop sustainable buildings to stay relevant as a company and be viable. Boverket could influence the integration by setting higher regulations regarding the upstream emissions from building materials, i.e. integrating LCA into the planning process of a new construction. This would benefit and stimulate the integration in a large extent.

7.3.3 Keep informed

The division of sales need to be informed about the integration of new materials to make the transition towards sustainability an action of competition. They have the main responsibility of attracting customers and make sure that they are satisfied. Other construction companies are the main competition but also catalyzes innovation to be integrated into the sector. Being an early adopter to materials with lower GHG emission could be a large advantage to a company and be advertised to the rest of the industry. Skeptics need to be informed in the advantages of integrating more sustainable options. The number of skeptics is difficult to know, they could be present in the entire value chain and beyond that. There are skeptics to all innovations and in the buildings sector specifically, there are skeptics in using timber as a construction material. On the other hand, there is also skeptics on sustainable concretes and the development of them. In a general sense there are even skeptics to climate change. To continue the work of sustainability it's important to keep these skeptics informed and try to convince them into the benefits. It's important to change the general picture of sustainable options and how conventional concrete isn't an option.

Keeping researchers in the area informed are of importance too. This could contribute to the development of a network between academia and the companies. It could also illuminate the demand of new sustainable materials and the development of them. The media is another stakeholder to keep informed as they are the main actor of sharing the development.

7.3.4 Monitor

The stakeholders to monitor are the UN, EU and the Swedish government. As their work towards sustainability is applied to a very general picture their specific impact on the building sector isn't the main force. However, it's important to monitor their development towards

sustainability and keep the goals set by these institutions in mind when developing own. Their power in developing tough sustainability goals shouldn't be forgotten.

7.4 Key innovation opportunities

There are several key innovation opportunities for integrating sustainable materials into the building sector. The large momentum of the industry makes it next to impossible for a single innovation to be integrated and be enough to solve the entire problem. Therefore, several innovations and the integration of them are needed to make sure the construction industry in Sweden fulfills the goal of net zero emissions 2045.

As seen throughout the report the possibilities for timber and the increase of market share for the product as building material is promising. As seen from the literature study and the interviews made at Veidekke the expectations on the material are high. However, the tough environment surrounding especially multifamily housing currently makes the margins of profit even lower. These lower margins act as a barrier for the integration of new materials, as the implementation of new materials would imply an investment in both time and funding. However, the construction companies could utilize these rough times to develop knowledge in how sustainability should be implemented in the company to maximize the development of it as soon as economic boom arises.

Standardization and modularization of CLT is a key aspect for increasing the familiarity and showcase the possibilities of using it. As a transition towards this, the usage of timber and concrete hybrids could be an innovation opportunity. This would increase the familiarity with CLT and pull the development of a shared standardization and certification of it. By having a standardization similar to concrete products, the comparison between timber and concrete products would become easier. This would benefit the timber products as their full potential could be revealed. The domestic timber industry in Sweden is a profound part of Sweden's economy and export. An increased usage of CLT in the building sector would benefit the domestic manufacturing of wall elements in timber and would open possibilities for a decentralized production. This development could follow the form of the municipality of Växjö where a local action plan increased the construction of timber buildings and created local job opportunities of the manufacturing of timber elements. The possibilities of using CLT on existing housing, for renovation and densifying urban areas should also be seen as a key innovation opportunity concerning the building material. Due to the light weight densification could be done onto existing houses and create new possibilities for both multifamily and commercial houses. Projects like this is already developed in Stockholm and should be investigated further. The market share of CLT today is minimal compared to the concrete industry. Still, the price of the material is quite competitive to conventional concrete. An increased market share could generate lower prices and at the same time develop a familiarity and knowledge in how to construct with the material. This could ultimately result in cheaper timber buildings.

As described earlier won't a single innovation solve the goal of sustainability in the construction industry. Therefore, the development of concrete and the usage of it will be important too. Continuing the research on modified design mixing and exploring the possibilities of using untreated ingredients with pozzolanic behavior as limestone powder as a

supplement to cement seems promising according to this report. Decreasing the amount of concrete in prefabricated elements is also an important opportunity. By creating beams and wall elements with hollow cores, comparable with the technique used at the project Viva by Riksbyggen, described earlier in this report. By having these hollow cores both the amount of concrete is decreased and the emissions from transport as simultaneous the weight of the elements is decreased.

Developing new types of fire proofing plasterboards or changing the insulation to a more fire resistant one could be solutions to increasing the integration of CLT and minimize the uncertainties regarding fire safety. Simple solutions as changing EPS insulation to a more fire-resistant insulation like mineral wool could be one solution. Overall research on improving fire safety in timber buildings need to be conducted. As of today, the regulations of Boverket are fulfilled. These regulations, however, doesn't account for the materialistic damage of the building. Improving the fire resistance of the actual framework and lowering the materialistic damage in case of a fire would then be a positive impact for CLT as a building material. This increased fire safety would decrease the uncertainty raised by insurance companies and lead to lower insurance premiums. This would provide to the process of lowering the production costs of CLT buildings. Timber concrete composites or hybrids is also a possible resolution for increasing the fire safety.

Looking further into the actions of a construction company like Veidekke, the development of knowledge and involvement should be concentrated to the divisions of purchase and the business developers. The divisions of purchase have a large opportunity, if time and effort is invested, to explore new subcontractors and manufacturers of products with lower GHG emissions. The business developers have a large potential to influence the work of sustainability too. If pursuing projects with clear and high set goals of sustainability the chance of the projects being successful is increased. Simplifying and break down the end goal of net zero emissions 2045 needs to be done to visualize the work ahead. By mapping out the work of sustainability in the company one could make sure that the entire work force is reaching for the same goal. This would also enable the employers with key competence in sustainability work to spread this knowledge with others, resulting in a joined force towards sustainability. The key innovation opportunity is to change the mindset to see the work of sustainability as a source of competition and that it can be linked to economic growth.

In general, the work towards sustainability needs to be from the employers, as described in the social challenges, they are the ones with in dept knowledge in the everyday processes and improvements that could be done. The work of sustainability shouldn't exclude the cultural aspects as behavioral patterns and structures at the company. If they are included the chances of the implementations being successful increases. To make this possible the managers need to see sustainability as a strategic choice and see the funding needed towards sustainability an investment for reaching profitability in the future. Being an early adaptor in the technology change towards the usage of more sustainable building materials could benefit the company by larger profits in the future due to the knowledge already being developed within the company.

Chapter-8

8. Conclusion and future work

As the report states, building with more sustainable materials is viable and can compete with conventional reinforced concrete. A single innovation won't solve the entire problem, working with several different solutions are key to enable Sweden to fulfill the goal of net zero emissions 2045. Working with several technologies will also result in a more resilient and robust construction industry were the lock-in present today towards concrete won't arise. In this report the opportunities of CLT and Eco-concrete was found to be most preferable. CLT used in multifamily houses are beneficial both in the aspect of lowering the GHG emissions but also for delivering buildings in good quality, aligned with the regulations from Boverket. The properties of building in CLT have shown several beneficial aspects and implies that the market is ready for a higher share of implementation. The transition from early adopter to early majority should occur soon. In the next economic boom, if the knowledge is developed correctly within a company, the implementation easily could increase. In addition, the Swedish building sector could benefit from utilizing the large domestic industry of timber. Main barriers are the fire safety to the construction itself and the lack of a standardized range of products. The standardization today is different in each country and lack the same understanding of the product and its possibilities in the value chain as concrete.

The market share of CLT today is minimal compared to the concrete industry. Still, the price of the material is quite competitive to conventional concrete. An increased market share could generate lower prices and at the same time develop a familiarity and knowledge in how to construct with the material. This would ultimately result in cheaper timber buildings. A preferable work of action could be to construct hybrids with concrete and timber to increase the integration and familiarity of timber into the building sector. This is a work of action found to be interesting both from the literature study, the analysis and the interviews at Veldekke.

The Eco-concrete presented in this report is found to be an attractive alternative to conventional concrete. As it uses a powder of limestone rather than conventional cement, fly ash and slag the GHG emission of the concrete is kept low. As the familiarity of concrete is well known in the entire value chain this concrete could be a great alternative for reaching lower GHG emission in the building sector. The maturity of Ecoconcrete is rising as applications to prefabricated concrete elements have been done. In addition to the results of finding more sustainable concrete options it's shown to be difficult to present an objective approach to what sustainable concrete is. As of today, substitutes like fly ash and slag are common and apart of some of the investigated concretes. The debate on considering fly ash and slag as carbon neutral is of current interest and could create confusion in the building sector. This is a barrier of growth.

introducing the requirement of LCA when constructing new buildings, the actions of choosing sustainable materials could be visualized and clarified.

The complicated value chain in the construction industry affects the possibilities of integrating new building materials into the processes. The key stakeholders for the integration are business developers, the department of purchase, the timber and concrete industries and customers demanding sustainable options.

Lastly, choosing a building material with lower GHG emission can't reach the goal of net zero emissions itself. It's important to optimize the entire value chain to make sure other parts of the construction contributes to minimizing the emissions. Important factors could be to choose effective energy systems that could reach a passive housing, i.e. the house itself produce the energy needed. Another important factor found by several researchers in the area is to minimize the energy consumption of the site huts. The site huts contribute to the emissions of a construction and as they often are used for several years during the construction it's also important to make sure their energy consumption is kept low. This thesis shows the importance of every part of the value chain to contribute on minimizing the GHG emissions from the construction industry. This challenge isn't a challenge that can be, or should be, solved by an actor alone. Collaboration, knowledge and having sustainability as a factor of competition is of essence to make sure the construction industry is sustainable in the future.

8.1 Future work

To strengthen the results of this thesis future work could be:

- Test the investigated materials during the two last phases of an LCA analysis to develop a general picture of their emissions during their entire lifetime
- Research the possibilities of having Eco-concrete being manufactured and delivered to large developments
- Possibilities of standardizing and modularizing timber products
- Further investigations on modified design mixing, pozzolanic materials and superplasticizers
- Develop pathways for integrating timber into concrete structures to create hybrids
- Build up a bank of knowledge of materials, their properties, emissions etc. to introduce the work of sustainability into the value chain
- Interview Boverket and municipalities to investigate their interest of pushing more sustainable building materials into the sector.

Chapter-9

9. References

- ADEC Innovations. (2018, 01 01). *What is Social Sustainability?* Retrieved from ADEC Innovations:
<https://esg.adec-innovations.com/about-us/faqs/what-is-social-sustainability/>
- Alinea. (2017). *Residential Timber Cost Model*. London: Alinea.
- Andrew, R. M. (2018). *Global CO2 emissions from cement production*. Oslo: Earth System Science Data.
- Anund Vogel, J., Lundqvist, P., & Arias, J. (2015). *Categorizing barriers to energy efficiency in buildings*. Stockholm: Elsevier.
- Anund Vogel, J., Lundqvist, P., Blomkvist, P., & Arias, J. (2015). *Problem areas related to energy efficiency implementation in Swedish multifamily buildings*. Dordrecht: Springer.
- Au Kai-Ming, A., & Enderwick, P. (2000). *A cognitive model on attitude towards technology adoption*. Hong Kong: MCB UP Ltd.
- Australian Urethane & Styrene. (n.d.). *Expanded Polystyrene EPS*. Kings Park: Australian Urethane & Styrene.
- Barrett, Byrd Associates. (2014). *Steel Construction Embodied Carbon*. London: The British Constructional Steelwork Association.
- Bauhaus. (2018, 11 01). *CELLPLAST S100 2400X1200X200MM 8,64 M² 3ST PER PAKET*. Retrieved from Bauhaus: https://www.bauhaus.se/cellplast-s100-2400x1200x200mm-8-64-m-perpaket.html?gclid=CjwKCAjwyOreBRAYEiwAR2mSkla9Mx68R5FKF1E7MXoqHNHjWaJjnzMM_9uRbr-Se2hLQPIT59S1hoCumQQA_vD_BwE
- BEST, O. (2017). *CLT ACCELERATION IN OREGON & SW WASHINGTON*. Portland: Oregon BEST.
- Betonginitiativet. (2018, 01 01). *Om oss*. Retrieved from Betonginitiativet:
<https://betonginitiativet.se/omoss/>
- Björklund, L. (2018, 10 15). Studiebesök på Branddöreen. (E. Arnesson, Interviewer)
- Blomkvist, P. (2017, 09 14). *Industrial Dynamics of Innovation in Combined Energy Systems*. (P. Blomkvist, Performer) KTH, Stockholm, Sweden.
- Boverket. (2018). *Boverkets byggregler – föreskrifter och allmänna råd*. Karlskrona: Boverket.
- Brandner, R., Flatscher, G., Ringhofer, A., Schickhofer, G., & Thiel, A. (2016). *Cross laminated timber (CLT): overview and development*. Berlin: Springer.
- Building Constructing Design. (2015, 09 10). *Building Constructing Design*. Retrieved from Carbon sequestration – locking up carbon and unlocking the full potential of timber:
<http://www.buildingconstructiondesign.co.uk/news/carbon-sequestration-locking-up-carbon-and-unlocking-the-full-potential-of-timber/>
- Business Dictionary. (2018, 01 01). *Economic sustainability*. Retrieved from Business Dictionary:
<http://www.businessdictionary.com/definition/economic-sustainability.html>

<https://buildingresiliencecoalition.org/comparing-the-costs-of-cross-laminated-timber-clt-and-cast-in-place-reinforced-concrete-structures/>

CBI Ministry of Foreign Affairs. (2017, 11 1). *Exporting cross laminated timber (CLT) to Western Europe*. Retrieved from CBI Ministry of Foreign Affairs: <https://www.cbi.eu/marketinformation/timber-products/cross-laminated-timber/europe/>

Chau, C., Hui, W., Ng, W., & Powell, G. (2018). *Assessment of CO2 emissions reduction in high-rise concrete office buildings using different material use options*. Hong Kong: Elsevier.

CPSA. (2011). *Carbonation (Part 1) – How it reduces the carbon footprint of concrete*. Leicester: CPSA.

Dehre, S. (2018, 11 28). Interview investigating the social barriers towards sustainability at Veidekke. (E. Arnsson, Interviewer)

Dong, Y. H., Jaillon, L., Chu, P., & Poon, C. (2015). *Comparing carbon emissions of precast and cast-in-situ construction methods – A case study of high-rise private building*. Hong Kong: Elsevier.

Appendix I

Calculations of U-values, CO₂ emissions and cost for the different materials.

Reference wall

Reference wall with prefabricated concrete and insulation of EPS insulation. The concrete is reinforced with 100 kg steel per m³.

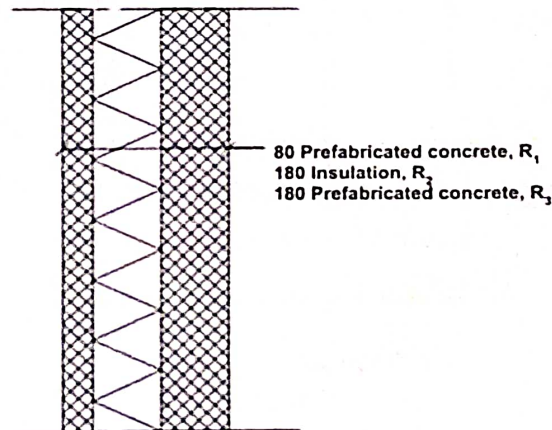

The thermal conductivity of the two materials is presented in Table 12 below.

Table 12. Thermal conductivity of elements

Material	Thermal conductivity, k [W/mK]	Reference
Prefabricated concrete	1.5	(Engineering Toolbox, 2003)
EPS insulation	0.037	(Bauhaus, 2018)

The U-value is calculated by the equation

Were

$$U = \frac{1}{R_1 + R_2 + R_3}$$

$$R = \frac{d}{k}$$

And variable d is thickness of respectively material in meters. The calculation gave the reference wall a Uvalue of 0.198 W/m²K.

To produce a wall element, illustrated in Figure 16 below, in the concrete used by the manufacturer, 107 kg CO₂/m²_{wall} is emitted. The emission was calculated by having the volume, presented in Table 13 below and the CO₂ emission, presented in Table 14 below, for each element.

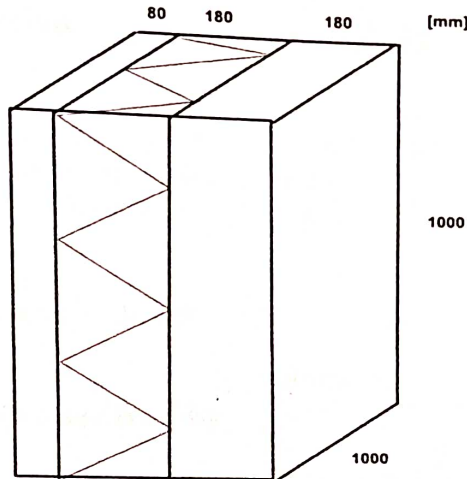

Figure 16. Concrete wall element

Table 13. Volume of elements in reference wall using concrete

Element	Volume [m ³]
Concrete	0.26
Insulation	0.18

The density of insulation is 21.5 kg/m³ which results in an insulation mass of 3.87 kg/m²_{wall} (Australian Urethane & Styrene).

Table 14. CO₂ emission of each substance

Element	CO ₂ emission	Reference
---------	--------------------------	-----------

Reference concrete	256 kg CO ₂ -eq/m ³	(Tosic, Marinkovic, Dasic, & Stanic, 2015)
EPS Insulation	1.91 kg CO ₂ -eq/kg	(Tahiri, 2011)
Reinforcing steel	1.27 kg CO ₂ -eq/kg	(Barrett, Byrd Associates, 2014)

The price of this wall elements being produced and delivered were 191 €/m²_{wall}. 30.3 % of this price is the cost of the transportation from the factory to the construction site. Excluding the transportation costs results in 133.2 €/m²_{wall}. This includes the labor costs and price for insulation and reinforcement too. Price per cubic meter including labor costs and all materials is 511.9 €/m³. 765 m² were delivered to the site for a price of 630 175 PLN (polish zloty). The currency used is 1 PLN = 0.23187 €.

CLT wall

The price of a CLT wall being produced is found to be 1430 SEK/m²_{wall}, including material and labor costs. This corresponds to a price of 138.6 €/m²_{wall}. The currency used is 1 SEK = 0.09694 €.

Calculation of the CO₂ emissions from producing a wall element in CLT, corresponding to the one described in Figure 7, was made according to the volume presented in Table 15 below. The volume of panel and veneer boards are included in the area for CLT.

Table 15. Volume of each element in the CLT wall

	Volume [m ³]
CLT (including panel and veneer boards)	0.145
Insulation	0.2
Plasterboard	0.015

The CO₂ emission of each element is presented in Table 16 below. Density of insulation is estimated to 21.5 kg/m³, resulting in 4.3 kg needed per square meter (Australian Urethane & Styrene). The density of the plasterboard is estimated to 800 kg/m³, resulting in 12 kg needed per square meter (Ruuska, 2013).

Table 16. CO₂ emission for each element in the CLT wall

	CO ₂ emission	Reference
CLT	-676 kg CO ₂ -eq/m ³	(Building Constructing Design, 2015)

This results in -66.19 kg CO₂/m²_{wall} produced.

Recycled aggregate concrete (RAC)

The price of RAC is found to be 10 % more expensive than conventional concrete. Therefore, the cost of producing a wall element, illustrated in Figure 16, in RAC is calculated to be 146.52 €/m²_{wall}.

To produce a wall element, illustrated in Figure 16, in RAC, 127.75 kg CO₂/m²_{wall} is emitted. The emission was calculated by having the volume, presented in Table 13 and the CO₂ emission, presented in Table 17 below, for each element.

Table 17. CO₂ emission of each substance

Element	CO ₂ emission	Reference
RAC	336 kg CO ₂ -eq/m ³	(Tosic, Marinkovic, Dasic, & Stanic, 2015)
EPS Insulation	1.91 kg CO ₂ -eq/kg	(Tahiri, 2011)
Reinforcing steel	1.27 kg CO ₂ -eq/kg	(Barrett, Byrd Associates, 2014)

Alkali-Activated concrete (AA concrete)

To produce a wall element in AA concrete, referring to the dimensions of Figure 16 and the CO₂ emissions presented in Table 18 below, results in 87.53 kg CO₂/m²_{wall}.

Table 18. CO₂ emission of each element to produce reference wall in AA concrete

Element	CO ₂ emission	Reference
AA concrete	181.3 kg CO ₂ -eq/m ³	(Yang, Song, & Song, 2017)
EPS Insulation	1.91 kg CO ₂ -eq/kg	(Tahiri, 2011)
Reinforcing steel	1.27 kg CO ₂ -eq/kg	(Barrett, Byrd Associates, 2014)

Eco-concrete

To produce a wall element, illustrated in Figure 16, in Eco-concrete, 46.39 kg CO₂/m²_{wall} is emitted. The emission was calculated by having the volume, presented in Table 13 and the CO₂ emission, presented in Table 19 below, for each element. The reinforcing steel is excluded as the emissions of it is included in the emissions from the concrete.

Table 19. CO₂ emission of each substance used in the Eco-concrete wall

Element
Eco-concrete

CO₂ emission
150 kg CO₂-eq/m³

Reference
(Keun-Hyeok, Yeon-Back,
Myung-Sug, & Sung-Ho,
2015)

EPS Insulation

1.91 kg CO₂-eq/kg

(Tahiri, 2011)